

Pressure Booster System

MODEL 75

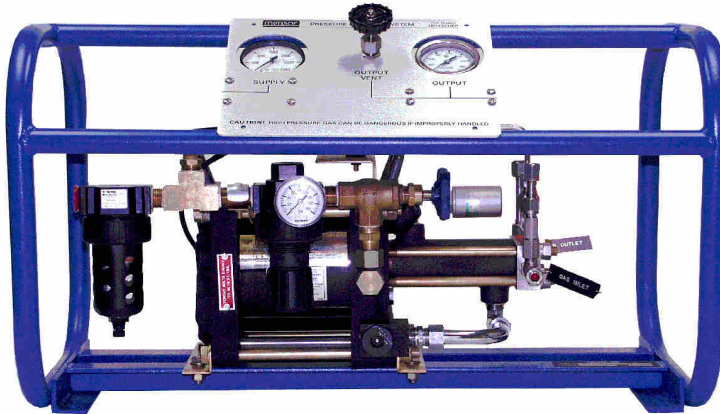

MODEL 75

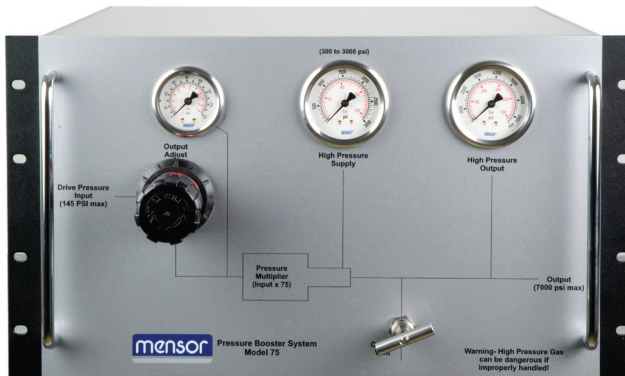

MODEL 75 RACK MOUNT

Model 75 & Model 75 Rack Mount Pressure Booster System



Warning

This Warning symbol indicates that danger of injury for persons and the environment and/or considerable damage (mortal danger, danger of injury) will occur if the respective safety precautions are not taken.



Caution

This Caution symbol indicates danger for the system and material if the respective safety precautions are not taken.

Table of Contents

1. General Information	4
1.1 Warranty	4
1.2 Important Notice	4
2. Safety Notices	5
2.1 Warnings and Caution Notices	6
3. Description	7
3.1 General	7
3.2 Ports	7
3.2.1 Drive Pressure Port	7
3.2.2 Supply Pressure Port	7
3.2.3 Output Pressure Port	7
3.3 Controls and Adjustments	8
3.3.1 Drive Pressure Regulator	9
3.3.2 Drive Speed Valve	9
3.3.3 Output Pressure Relief Valve	9
3.3.4 Output Vent Valve	9
3.3.5 Air Pilot Switch	9
Figure 1 - Mechanical Views (open frame)	10
4. Specifications	11
Figure 2 - Model 75	12
Figure 3 - Model 75 Rack Mount (front and rear view)	12
5. Operation	14
6. Discontinue Operation	14
7. Maintenance	15
7.1 Drive Pressure Filter	15
Figure 4 - Pneumatic Schematic	15

Model 75 & Model 75 Rack Mount Pressure Booster System

1. General Information

1.1 Warranty

All products manufactured by Mensor are warranted to be free of defects in workmanship and materials for a period of one year from the date of shipment. No other express warranty is given, and no affirmation of Seller, by words or actions, shall constitute a warranty. SELLER DISCLAIMS ANY IMPLIED WARRANTIES OF MERCHANTABILITY OR FITNESS FOR ANY PARTICULAR PURPOSES WHATSOEVER. If any defect in workmanship or material should develop under conditions of normal use and service within the warranty period, repairs will be made at no charge to the original purchaser, upon delivery of the product(s) to the factory, shipping charges prepaid. If inspection by Mensor or its authorized representative reveals that the product was damaged by accident, alteration, misuse, abuse, faulty installation or other causes beyond the control of Mensor, this warranty does not apply. The judgment of Mensor will be final as to all matters concerning condition of the product, the cause and nature of a defect, and the necessity or manner of repair. Service, repairs or disassembly of the product in any manner, performed without specific factory permission, voids this warranty.

MENSOR MAKES NO WARRANTY OF ANY KIND WITH REGARD TO THIS MANUAL, INCLUDING, BUT NOT LIMITED TO, THE IMPLIED WARRANTIES OF MERCHANTABILITY AND FITNESS FOR A PARTICULAR PURPOSE. Mensor shall not be liable for errors contained herein or for incidental or consequential damages in connection with the furnishing, performance, or use of this material.

1.2 Important Notice

The product specifications and other information contained in this manual are subject to change without notice.

Mensor has made a concerted effort to provide complete and current information for the proper use of the equipment. If there are questions regarding this manual or the proper use of the equipment, contact either Mensor or WIKA:

Mensor
201 Barnes Drive
San Marcos, Tx 78666
Tel: 1.512.396.4200
1.800.984.4200 (USA only)
Web Site: www.mensor.com
Fax: . 512.396.1820
E-Mail: sales@mensor.com
tech.support@mensor.com

WIKA Alexander Wiegand SE & Co. KG
Alexander-Wiegand-Straße 30
D-63911 Klingenberg / Germany
Tel: (+49) 93 72/132-9986
Web Site: www.wika.de
Fax: (+49) 93 72/132-8767
E-Mail: testequip@wika.de

2. Safety Notices

2.1 Warning and Caution Notices



Warning

WARNING! Pressurized vessels and associated equipment are potentially dangerous.

The apparatus described in this manual should be operated only by personnel trained in procedures that will assure safety to themselves, to others, and to the equipment.

The users, through their own analysis and testing, are responsible for assuring that all performance, safety and warning requirements are met, and for the training of the user personnel in the operation of high pressure systems.

Do not exceed safe, maximum generated pressures as defined in this manual.

When any maintenance is performed, remove all pressure from booster.



Warning

WARNING: INJURY THROUGH IMPROPER USE! Do not use the instrument with materials and mixtures of the group 1 (hazardous fluids) according Regulation (EC) no. 1272/2008.



Caution

CAUTION! High pressure gas can be extremely dangerous if improperly handled.

PLEASE READ THE ABOVE CAUTION AGAIN. THE HAZARDS OF IMPROPERLY HANDLING HIGH PRESSURE GAS OR AIR CANNOT BE OVERSTATED.

Model 75 & Model 75 Rack Mount Pressure Booster System



Caution

CAUTION! The output vent valve vents the high pressure media to the atmosphere in the immediate vicinity. Safety precautions must be observed.



Caution

CAUTION! Always use replacement parts specified by Mensor Corporation.



Caution

CAUTION! Do not mix fluid types.

Additional safety notices are found throughout this manual.

3. Description

3.1 General



Caution

CAUTION! HIGH PRESSURE GAS CAN BE EXTREMELY DANGEROUS IF IMPROPERLY HANDLED.

PLEASE READ THE ABOVE CAUTION AGAIN. THE HAZARDS OF IMPROPERLY HANDLING HIGH PRESSURE GAS OR AIR CANNOT BE OVERSTATED.

It is the operator's responsibility to assure that the tubing and fittings used in the system meet the following conditions:

- Must have a working pressure rating equal to or greater than the maximum required pressure.
- Must be in good mechanical condition, i.e., good threads on fittings, tubing free of kinks or nicks, etc.
- Must be properly installed and tightened.

When designing the overall pressure system, minimize the total volume external to the Pressure Booster System (PBS) as much as possible. Larger volumes take longer to vent, whether due to an intentional shutdown or a catastrophic failure of some pressure seal or other component. The danger posed by the failure of a system with a larger volume is that it will increase the time it takes for the pressure to fully vent to atmosphere. The venting gas from the PBS can pose several hazards:

1. The gas used will most likely be an inert gas such as Nitrogen. Under conditions of high exhaust flow and confined spaces the Oxygen in the immediate vicinity of the exhaust may be displaced, leading to fatigue or even death to those breathing such Oxygen deprived atmosphere.
2. Small articles exposed to the escaping gas can be propelled at ballistic speeds to the endangerment of nearby personnel and equipment.
3. Under certain conditions, the noise level created by the gas exiting equipment under high pressure can become dangerously high.

Model 75 & Model 75 Rack Mount Pressure Booster System

The PBS uses low pressure shop air to drive a dual piston booster to compress a supply gas to 75 times the drive pressure. The high pressure gas is then output to an external load. The standard configuration is a cage mounted open frame unit designated as the Model 75. Mounted in a rollbar frame, the unit includes an operator control panel, with gauges for supply pressure, output reference pressure and an output vent valve. Safety features include internal 4x rated stainless steel tubing, an auto shut-off valve and an output relief valve. The PBS requires a drive pressure input from shop air and supply pressure input from bottled nitrogen or another inert gas. The output pressure is adjustable by a knob on the drive pressure regulator. A nitrogen pressure regulator is not required, as the unit will function with any supply gas pressure from 300 to 3000 psig. The auto shut-off valve shuts down the system if bottle pressure is less than 300 psig.

The PBS can also be mounted within a standard 19" rack enclosure taking 10.5 inches of rack space and having a depth of approximately 20 inches.

3.2 Ports

There are three pressure ports on the PBS: Drive, Supply, and Output. The Supply and Output ports on the open frame chassis (Model 75) require 7/16-20 MS (O-ring) fittings. The Drive port is female 1/2" NPT. The fittings to adapt these ports to tubing are provided with the PBS. Other types of fittings are available. Refer to Figure 1 for the locations of the three ports. The rack mounted version of the PBS has male 1/4" Swagelok type tube fittings on the rear panel for the high pressure Supply and Output connections and has a female 1/2" NPT low pressure drive connection on the rear panel.

3.2.1 Drive Pressure Port

Usually the Drive port is connected to 'shop air' which may be as high as 145 psig. The recommended pressure is 100 psig. The Output Pressure will be 75 times higher than the pressure appearing on the Drive Pressure Gauge.

3.2.2 Supply Pressure Port

Provide this port with a clean, dry, inert gas such as nitrogen, at a pressure which may range from as low as 300 psig to as high as 3000 psig. This port has a built-in 20 micron sintered metal filter to prevent particulates of any significant size from entering the booster unit. Otherwise there could be damage to the PBS valve seats which would cause the Output Port pressure to leak back to the Supply Port.

3.2.3 Output Pressure Port

This port outputs the supply gas media raised to 75 times the pressure setting of the Drive Pressure Regulator. The output pressure is set by adjusting the Drive Pressure Regulator until the output pressure dial gauge reads the desired output pressure.

3.3 Controls and Adjustments

There are several controls and adjustments available to the user. Refer to Figure 1 for the location of the following items.

3.3.1 Drive Pressure Regulator

The Drive Pressure Regulator is a hand adjustment to set the output pressure. This regulator is mounted on the Drive Pressure Manifold of the Model 75, directly under the Control Panel or on the front panel of the rack mounted unit. The PBS is shipped with the Drive Pressure Regulator set to zero pressure. To change this value first unlock the knob at the base of the regulator by pulling down firmly or out for the rack mounted version, then adjust the knob for the desired value. It is recommended that the knob be relocked after adjustment.

3.3.2 Drive Speed Valve

The Drive Speed Valve is used to vary the driving speed of the booster piston. This control is located immediately to the right of the Drive Pressure Regulator on the open chassis version and internally on the rack mounted version. When shipped, the Drive Speed Valve is fully open for maximum speed. Additional information on setting the drive speed is provided in Section 5, Operation.

3.3.3 Output Pressure Relief Valve

The Output Pressure Relief Valve (not shown in Figure 1) is located on the underside of the control panel or internally on the rack mounted version. To set the cracking pressure of the relief valve to a different pressure loosen the jam-nut portion of the valve's lower body, then insert a 3/8 inch Allen wrench in the hole in the bottom of the valve. Turn the wrench in either direction to raise or lower the cracking pressure. The relief valve is factory set to 7000 psi.

3.3.4 Output Vent Valve

The Output Vent Valve is located on the control panel. This valve is used to relieve the output pressure from the Output Pressure Port, but only after the supply pressure has been shut off. If the vent valve is opened while there is pressure on the supply port, the

Model 75 & Model 75 Rack Mount Pressure Booster System

supply pressure will pass through the booster to the output port. Do not disconnect the supply and output lines until both the supply and output dial gauges read zero.



Caution

CAUTION: THE OUTPUT VENT VALVE VENTS THE HIGH PRESSURE MEDIA TO THE ATMOSPHERE IN THE IMMEDIATE VICINITY. SAFETY PRECAUTIONS MUST BE OBSERVED!

3.3.5 Air Pilot Switch

There is an Air Pilot Switch (see Figure 4 - Pneumatic Schematic) which will shut down the Pressure Booster if there is less than 300 psig pressure on the supply gas. It is not necessary to provide a pressure regulator on the supply line since the booster will function with any supply gas pressure from 300 to 3000 psig. There are no adjustments to the air pilot switch.

Model 75 & Model 75 Rack Mount Pressure Booster System

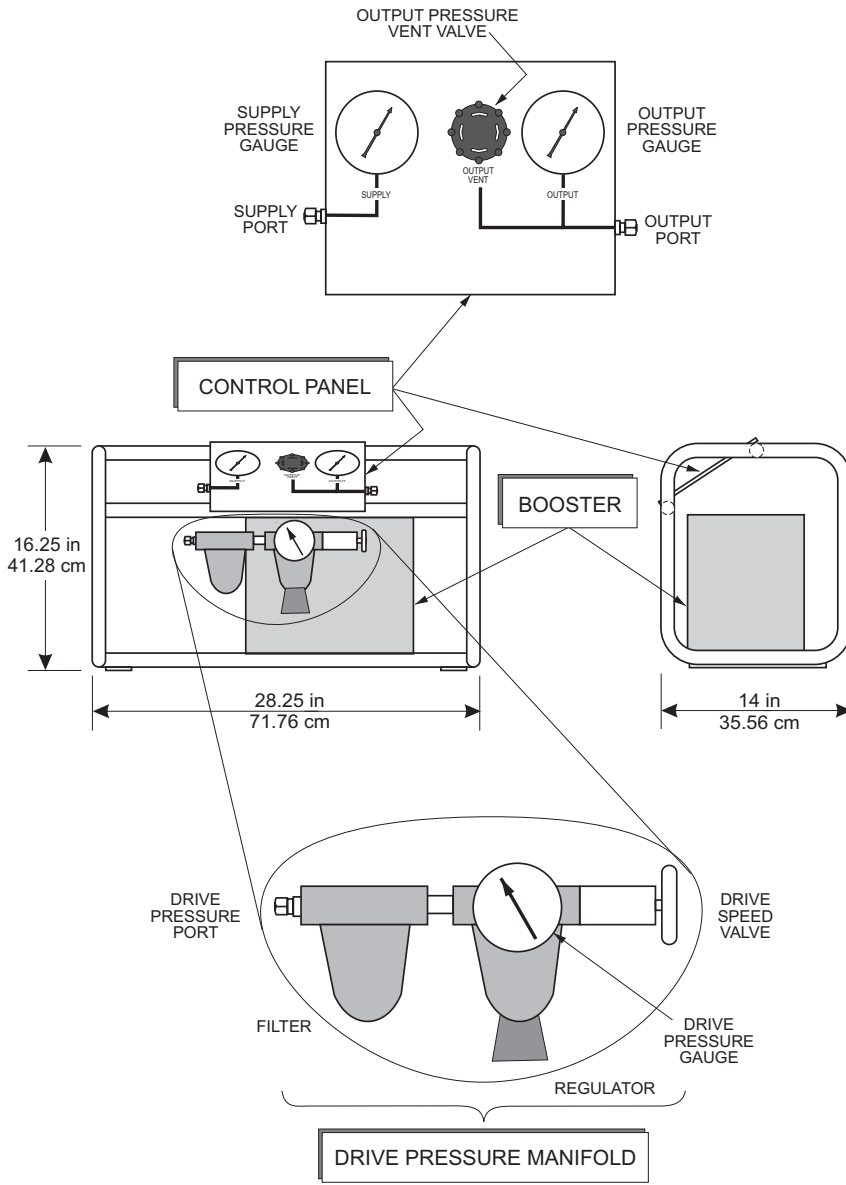

Figure 1 - PBS Mechanical Views (Open Frame)

Model 75 & Model 75 Rack Mount Pressure Booster System

4. Specifications

Input Drive Pressure	Maximum 145 psi 100 psi recommended Acceptable Media: Shop Air or better quality
Input Supply Pressure	Minimum: 300 psi Maximum: 3000 psi Media: Clean Dry Inert Gas (Nitrogen preferred)
Output Pressure	6500 psi typical 7000 psi relief valve setting 11250 psi Maximum Rated
Input to Output Ratio	Stall pressure approximately 75 times drive pressure setting.
Drive Speed	Adjustable using internal valve. Factory set to full speed setting.
Piston Displacement	1.2 cubic inches per cycle
Low Pressure Supply Shutdown	At approximately 300 psi and lower.
Filter	20 micron filter mounted on drive pressure manifold. Removable for cleaning.
Relief Valve	Output relief valve mounted on underside of control panel. Cracking pressure is adjustable.
Response Time	The time for the PBS to reach the desired output pressure will vary due to the volume to be filled and/or the available pressure at the nitrogen bottle connected to the supply input. Typical response with 2500 psig supply pressure is approximately 6 piston strokes per 100 cc of volume on output at 2 seconds/ piston stroke.
Noise	Model 75: 86 dB A average, 96 dB A peak, measured at 1 meter distance. Model 75 Rack Mount: 82 dB A average, 88 dB A peak, measured at 1 meter distance.
Size	Model 75: Length: 28.25" (71.76 cm) Width: 14.0" (35.56 cm) Height: 16.25" (41.28 cm) Model 75 Rack Mount: For standard 19" Equipment rack (10.5" tall, 6U): Front width: 19.0" Rear width: 17.0" Case depth: 17.0" with 3" for rear fittings and 3" for front adjustment knobs. Total depth: 23"
Weight	Model 75: 57 lbs. (25.85 kg) Model 75 Rack Unit: 49 lbs (22.3 kg)

Model 75 & Model 75 Rack Mount Pressure Booster System

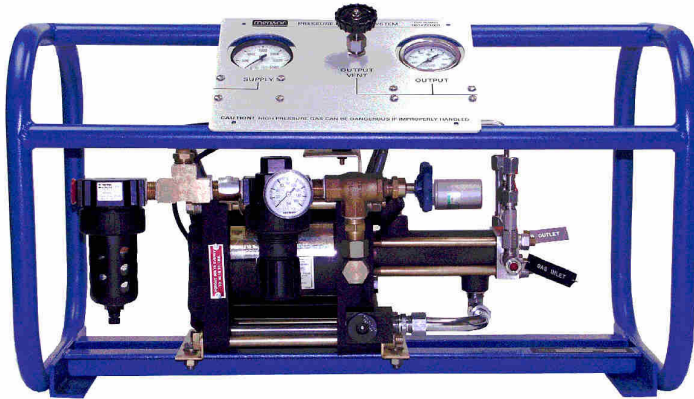

Figure 2 - Model 75



Figure 3 - Model 75 Rack Mount
(front and rear view)

Model 75 & Model 75 Rack Mount Pressure Booster System

5. Operation

While operation of the PBS is quite simple, high pressure gas is dangerous. Operation of this unit must be by fully qualified personnel only. To use the PBS:

1. Connect a low pressure supply such as shop air (approximately 100 psig) to the Drive Pressure port.
2. Connect the Output Pressure Port to the load which will be pressured by the booster. Be careful to use tubing rated for the boosted working pressure.
3. Connect the proper supply gas (from 300 to 3000 psig) to the Source Pressure Port.

For operation with a Mensor Model 410 or CPC 8000, as well as with similar applications, booster piston temperature will not be a problem. However, if a particular application causes the booster piston to operate frequently the high pressure end of the booster cylinder may overheat. Temperatures in the cylinder above 300 degrees F will considerably shorten life of the piston seal.

There are two main factors in booster temperature:

1. The ratio of output pressure to supply pressure. A ratio of about three to one (3:1), or less, will help to minimize this temperature.
2. The drive speed. The Drive Speed Valve can be closed to the point of the slowest drive speed that will still maintain the required output pressure.

If the drive cylinder temperature appears to be a continuing problem install a thermocouple about one inch from the discharge port of the booster unit. Then monitor the temperature whenever the booster is in operation. When the temperature gets excessive either adjust the Output/Supply pressure ratio, adjust the Drive Speed Valve, or shut down the operation until the booster cools down.

6. Discontinue Operation

To discontinue operation of the PBS:

1. Close the supply pressure valve. Disconnect the supply gas if desired.
2. With the supply pressure cut off, vent the Output Pressure with the hand valve on the control panel. Wait for the Supply Pressure Gauge and the Output Pressure Gauge both to read 0 psig. The load may now be disconnected.
3. The Drive Pressure can be left on, or valved off and disconnected, as desired.

7. Maintenance

7.1 Drive Pressure Filter

Inspect the filter mounted on the Drive Pressure Manifold on a regular basis. Drain any accumulated moisture or sludge through the drain petcock on the base of the filter.

Occasionally clean the internal filter element inside the Drive Filter sediment bowl. To access the element, first disconnect all pressures from the system. Unscrew the filter bowl ring nut by hand and remove the bowl and filter element screw.

Clean the bowl with either soapy water or kerosene. Clean the element with a cleaning solvent. Dry all the parts and reassemble. Make sure that the O-ring seal for the bowl is properly positioned, replace the bowl and tighten the ring nut by hand.

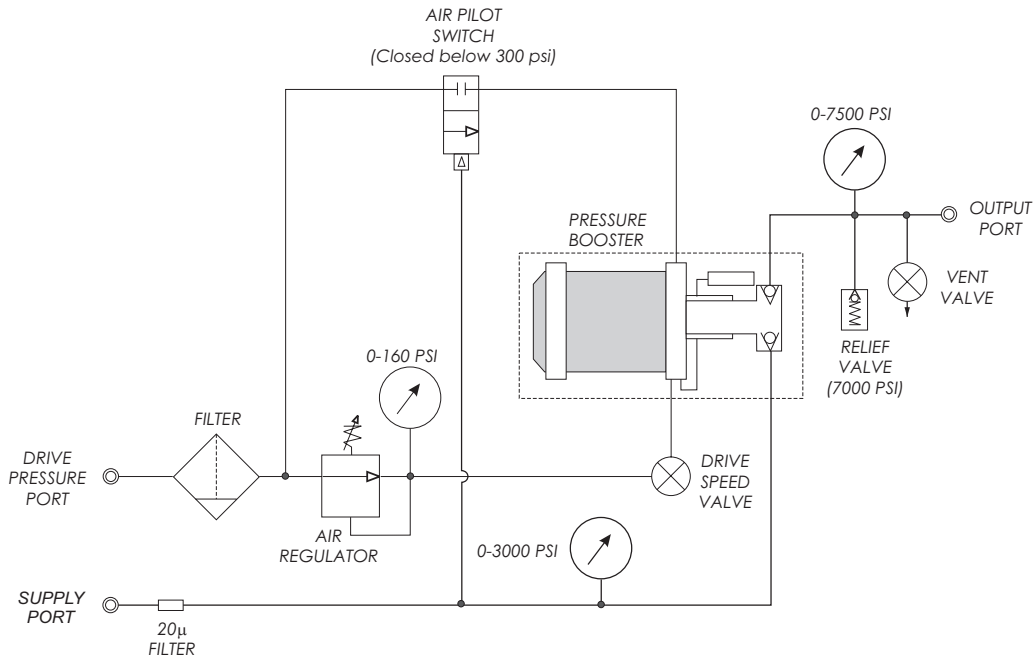

Figure 4 - Pneumatic Schematic



Mensor Corporation

201 Barnes Drive
San Marcos, TX 78666 • USA
Tel. (+1) 512 3964200-15
Fax (+1) 512 3961820
E-Mail sales@mensor.com
www.mensor.com



**WIKAI Alexander Wiegand SE
& Co. KG**

Alexander-Wiegand-Straße 30
63911 Klingenberg • Germany
Tel. +49 9372 132-0
Fax +49 9372 132-406
info@wika.de

Imported to UK by:

WIKAI Instruments Ltd,
Unit 6 & 7 Goya Business Park,
The Moor Road, Sevenoaks
Kent, TN15 5GY