

Everything You Wanted to Know About Setting Zero on an Absolute Pressure Transducer but Were Afraid to Ask

Robert Clayton
Mensor Corporation
Voice: 512.396.4200 Fax: 512.396.1820

Abstract

This paper presents some of the problems of zeroing absolute sensors. It also discusses some of the solutions to these problems. The physical constraints which cause flows to move from viscous to molecular regions are presented along with how this information can be used to develop better techniques and hardware for accurately setting zero points on absolute pressure transducers and instruments.

Introduction

One of the major problems with calibrating absolute pressure sensors is that it is impossible to generate an exact pressure point at which the sensor's offset can be nulled out. No matter how low the pressure applied to the sensor, it will never reach exactly zero pressure - unlike a gauge or differential pressure sensor, which simply has to be vented.

A common way in which absolute pressure sensors are zeroed is to connect them to the best vacuum source available and pump them down for many hours. A thermocouple vacuum gauge is commonly used to measure the pressure to which the sensor was adjusted. As Mensor became compliant to ANSI-Z540, the traceability of these thermocouple vacuum gauges was called into question. Typically a very low percentage of gauge tubes were found to be within their calibration accuracy at their calibration interval. We then purchased several diaphragm type capacitance vacuum transducers which gave us better accuracy and better resolution.

Empirical Data from an Instrument

Using these higher accuracy vacuum transducers, we began testing and found that at low absolute pressures there was a significant difference between the vacuum measured at the output port of our instruments and the internal sensor. A series of tests were run using the following setup:

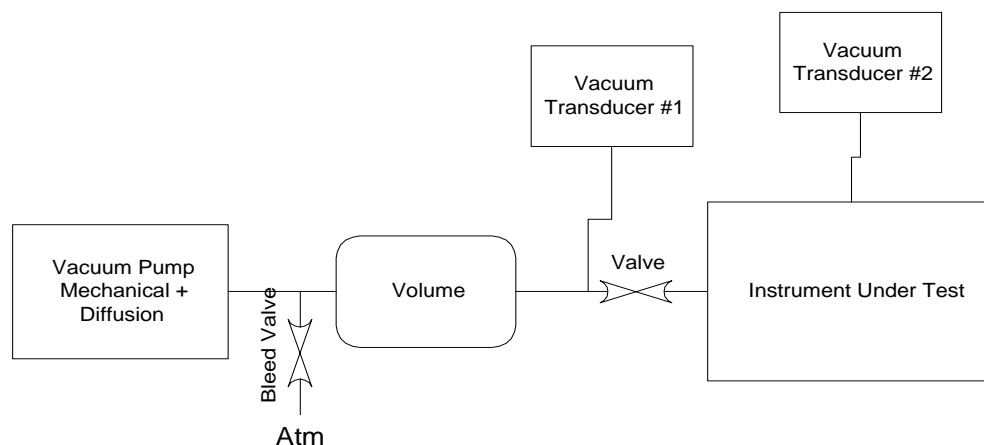

Figure 1 - Basic Instrument Test Setup

Figure 1 shows the basic test setup used. The bleed valve is a micrometer type valve used to control the pressure in the volume attached to the vacuum pump. Vacuum transducer #1 is used to measure the pressure at the measure/control port of the instrument (it is plumbed as closely as possible to the instrument.) The other valve is used to isolate the instrument so that the vacuum system can be stabilized at a known pressure. Vacuum transducer #2 is used to measure the pressure at the sensor in the instrument.

A series of tests were then run. The first used no bleed and pumped the system to as low a pressure as possible using a vacuum pump and a diffusion pump. The rest of the tests were then run in 50 mTorr increments starting at 100 mTorr through 300 mTorr. The results of the pressure measurements at vacuum transducer #2 are shown in Figure 2.

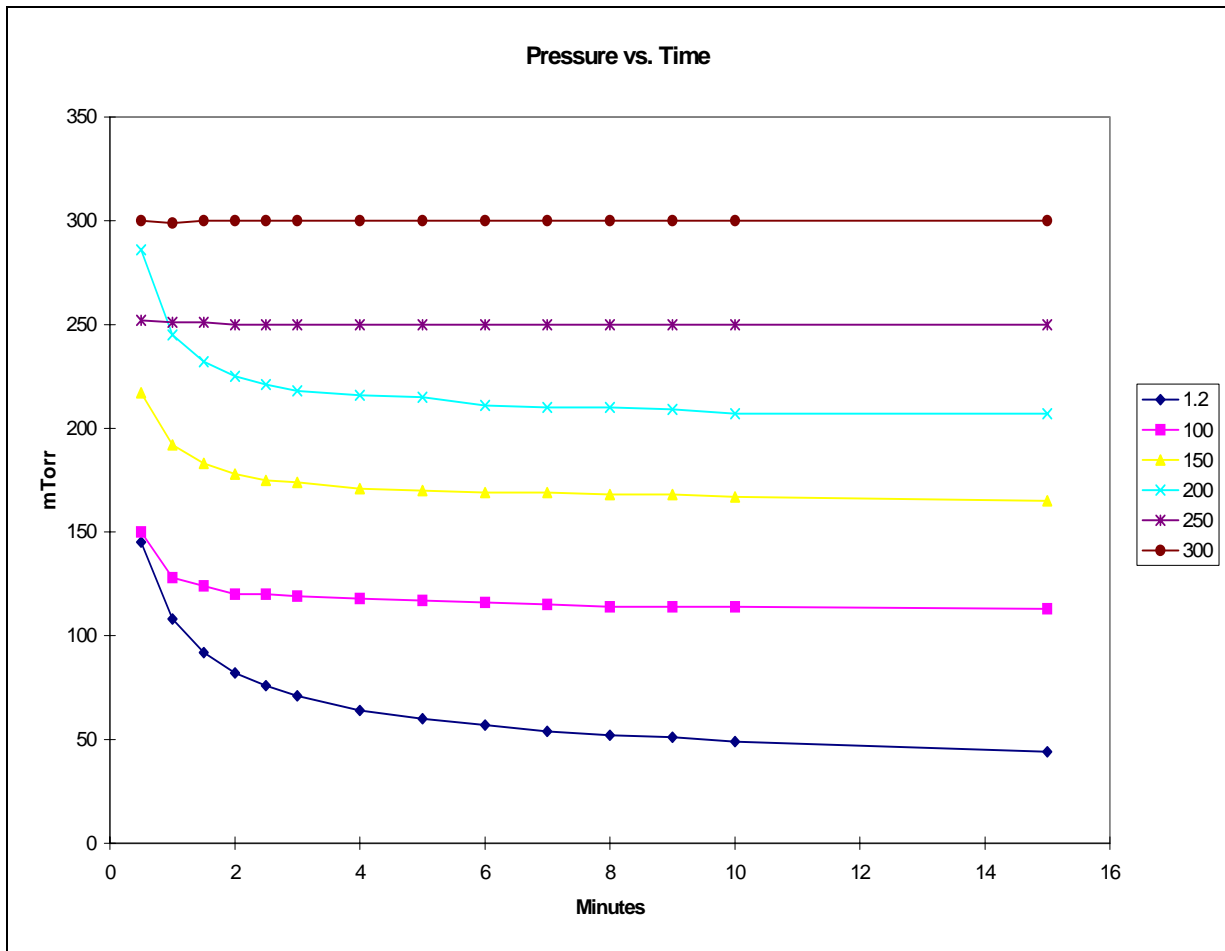

Figure 2. – Internal Instrument Pressure vs. Time for Various Starting External Pressures

From this graph, It is obvious that the lower the absolute pressure to be reached, the longer it takes the system to stabilize. What may not be so obvious is that after even an hour, below a certain threshold, the pressure inside and outside the instrument may never be the same. In the case of the lowest external starting pressure of 1.2 mTorr, the pressure at the instrument's sensor never got below 44 mTorr.

Empirical Data from different tubing

Of course, getting a stable low absolute pressure in the instrument is one thing, but there also must be some system considerations. Since these problems were found with the instruments, testing was also performed on the interconnecting tubing used from the vacuum source to the instrument.

Various types of commonly used tubing were tested, which were as follows:

- a) 0.25" OD, 0.100" ID nylon tubing
- b) 0.25" OD, 0.188" ID nylon tubing
- c) 0.375" OD, 0.285" ID nylon tubing
- d) 0.25" OD, 0.152" ID aluminum tubing

The series of tests was performed with a high performance vacuum pump/diffusion pump combination on one end and a capacitance type vacuum transducer on the other end of a 48 inch long piece of tubing. The tubing was as straight as possible. This test setup is shown in Figure 3.

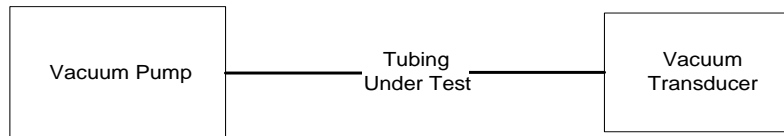

Figure 3. – Test Setup for Tubing Test

The results of the test were quite interesting. Not surprisingly, as the inside diameter of the nylon tubing increased, so did the rate at which the absolute pressure decreased. The aluminum tubing however outperformed all of the nylon tubing in pumping rate and ultimate vacuum achieved after the 20-minute test period. The results of this testing are shown in Figure 4

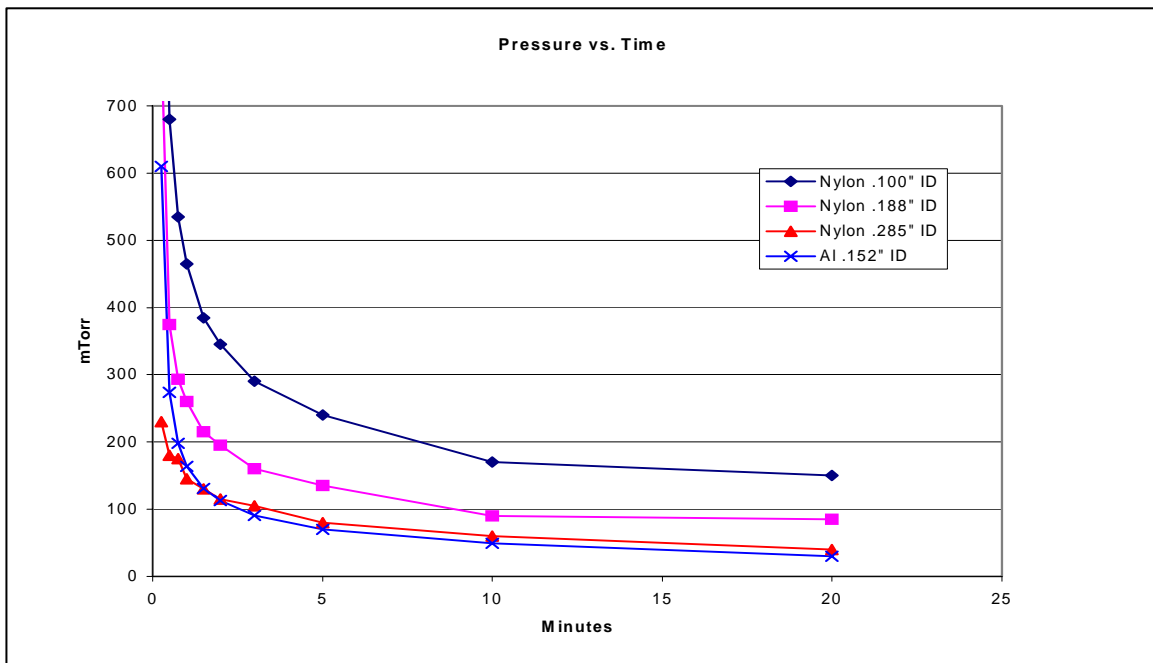

Figure 4. – Transducer Measurements on 48" Tubing Samples vs. Time

The results of this test show that not only is the geometry of a vacuum system important, so is the choice of materials used in that system. Generally metals have an order of two magnitudes faster rate of outgassing than non-metallic materials¹.

Theoretical Information

The major reason for the low pressure non-equalization is a matter of flow. Above a certain pressure, largely determined by the geometry of a system, the flow is viscous in nature. This is referred to as the Viscous Flow Region. The mean free path of the molecules is such that the interactions of the particles play a dominant role in determining the flow. In this region, pressures across systems equalize rapidly and this is where low pressure measurements should be made.

As the pressure continues to drop, a transition area is reached. This region is known as the Knudsen Flow Region. This area is somewhat suspect for making accurate low pressure measurements.

Below the transitional area is the Molecular Flow Region. In this region, the mean free path between molecules becomes equal to or greater than the distance to the walls of the tube. The molecules bounce around and randomly go through the restrictions in the system. In this region, it is often impractical to ever have a system stabilize in pressure.

The boundaries of these systems are shown in Figure 5. This is a graph pertaining to straight sections of piping which shows the transitional boundaries from viscous to Knudsen and Knudsen to molecular flow.

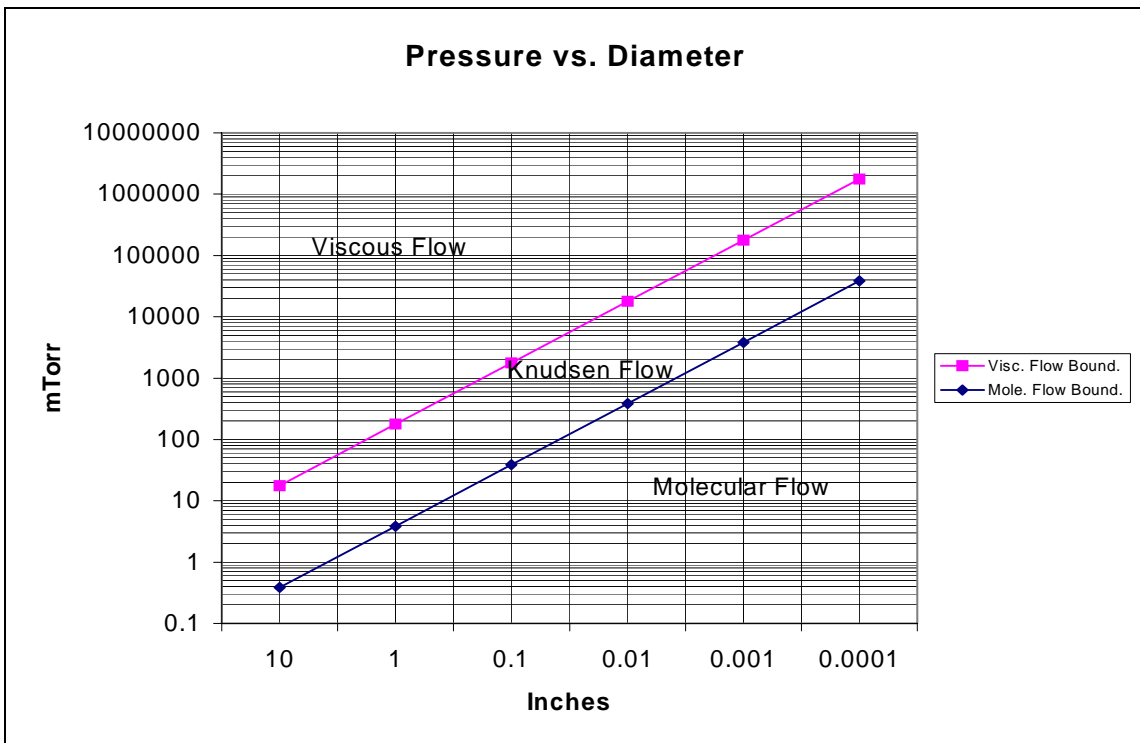

Figure 5. - Transitional Boundaries for Viscous and Molecular Flow

¹ Leybold-AG Vacuum Products; Product and Vacuum Technology Reference Book; 1992;p. 86

The boundary equations on this graph are derived for air at 20 deg. C.² and are:

For Viscous Flow: Pressure x Tube Diameter > 177.1804 mTorr Inch

For Molecular Flow: Pressure x Tube Diameter < 3.839 mTorr Inch

Practical Effects on Calibrations

One example of the effects of pressure measurement errors which can occur in the calibration of instruments is the error on a typical barometer. If a 32 in. Hg barometer were calibrated using a typical setup, the operator might think that pumping the instrument with a vacuum pump would create a zero pressure where in fact a 40mTorr pressure might be on the instrument. This would cause a 0.0049% F.S. error and the barometer would always read lower than the actual applied pressure. If the first 20% point of the calibration were achieved with a deadweight tester, a typical offset of the instrument used to measure a 100 mTorr bell jar pressure might be about 20 mTorr. This would cause a 0.0025% F.S. error. This would also occur in all the rest of the calibration points. This is shown in Figure 6.

Assumed Pressures	Actual Absolute Pressures	%F.S. Error
0.0000	0.0016	0.0049
6.4000	6.4008	0.0025
12.8000	12.8008	0.0025
19.2000	19.2008	0.0025
25.6000	25.6008	0.0025
32.0000	32.0008	0.0025

Figure 6. – Potential Typical Calibration Errors.

Not only would all the points be offset from the actual pressures, the barometer would appear to be non-linear.

Conclusions

1. Use a high enough pressure when zeroing that your system stabilizes rapidly and save calibration time.
2. Use a high enough pressure when zeroing so that your system's pressures are well known.
3. Use a low enough pressure when zeroing that you maintain required accuracy on your vacuum standard.
4. When constructing your system, don't use plastics or nylons that tend to adsorb water on their surfaces and have slow outgassing rates.
5. Minimize restrictions in your plumbing fixtures.
6. Save money - don't buy diffusion pumps or more vacuum pump than you really need.
7. Do empirical testing of your systems. The information provided in this paper is only a guideline. It is impractical to try to theoretically calculate the ideal pressure to use.

² Leybold-AG Vacuum Products; Product and Vacuum Technology Reference Book; 1992;p. 7