

Pressure balance Differential pressure version Model CPB5000DP



WIKA data sheet CT 31.52

Applications

- Reference instrument for the calibration of differential pressure measuring instruments under static pressure
- Primary standard for factory and calibration laboratories for the testing, setting and calibration of pressure measuring instruments
- Complete, stand-alone system, also suitable for on-site use

Special features

- Measuring range (= static pressure + differential pressure) up to 400 bar pneumatic, up to 1000 bar hydraulic
- Total measurement uncertainty up to 0.008 % of differential pressure plus 0.0001 % (1 ppm) of static pressure
- Factory calibration includes traceability to national standards, as standard; with DKD/DAkkS calibration possible as an option
- High long-term stability with recommended recalibration cycle every five years
- Disc weights from stainless steel and aluminium, adjustment to local gravity possible without additional cost



Pressure balance for differential pressure model CPB5000DP

Description

Proven primary standard

Pressure balances are the most accurate instruments available on the market for the calibration of electronic or mechanical pressure measuring instruments. The direct measurement of the pressure ($p = F/A$), along with the use of high-quality materials, makes possible such a small measurement uncertainty in conjunction with the excellent long-term stability of five years (as recommended by the German Calibration Service, DKD/DAkkS).

The pressure balance has therefore been used for years in factory and calibration laboratories in industry, national institutes and research laboratories.

Stand-alone operation

Due to its integrated pressure generation and the pure mechanical measuring principle, the model CPB5000 is ideal for on-site use for maintenance and service.

Basic principle

Pressure is defined as the quotient of force and area. The core component of the CPB5000 is therefore a very precisely-manufactured piston-cylinder system, which is loaded with masses in order to generate the individual test points.

The masses applied are proportional to the desired pressure and this is achieved by the use of optimally graduated weights. These weights are manufactured to the standard acceleration due to gravity (9.80665 m/s^2) as standard, though they can be adjusted to a specific location and also DKD/DAkkS calibrated.

Easy operation

The way the pressure is set depends on the instrument design and is either via an integrated pump or from external pressure generation via a metering valve. For fine adjustment, a very precisely-controllable spindle pump is fitted, with a precision spindle running within it.

As soon as the measuring system reaches equilibrium, there is a balance of forces between the pressure and the mass

The piston-cylinder system

Both the piston and cylinder are manufactured from tungsten carbide. Compared to other materials, tungsten carbide has very small pressure and thermal expansion coefficients, which results in a very good linearity of the effective cross-sectional area of the piston and thus a high measurement accuracy.

Piston and cylinder are very well protected, against contact, impacts or contamination from outside, in a solid stainless-steel housing. At the same time, overpressure protection is integrated, which prevents the piston from being forced out vertically and avoids damage to the piston-cylinder system in the event of weight removal under pressure.

The disc weights are stacked on a bell jar which is fitted to the piston shaft. The construction of the bell jar provides a very low centre of gravity for the stacked weights, which minimises both the side thrust on the piston-cylinder system and the friction. For relatively low starting pressures, a lighter aluminium plate can be used instead of the bell jar.

The overall design of the piston-cylinder unit and the very precise manufacturing of both the piston and the cylinder, ensure excellent operating characteristics with a long free-rotation time, low sink rates and a very high long-term stability. Therefore the recommended recalibration interval is five years.

applied. The excellent quality of the system ensures that this pressure remains stable over several minutes, so that the pressure value for comparative measurements can be read without any problems, or also so that more time-consuming adjustments can be carried out on the test item.

High-performance instrument range

The CPB5000DP base instruments are available in the following three designs:

- Instrument base, pneumatic
 - up to a max. 100 bar/1,500 psi
 - with integrated pressure generation through booster pump and spindle pump
 - connection for external pressure supply
- Instrument base, pneumatic with integrated gas to oil separator
 - up to a max. 400 bar/5,000 psi
 - connection for external pressure supply
 - for use with hydraulic piston-cylinder systems with M30 x 2 connection
 - Test item can be easily, dryly and cleanly calibrated with air
- Instrument base, hydraulic
 - up to a max. 1,000 bar/14,500 psi
 - with integrated pressure generation through booster pump and spindle pump
 - special versions available to 1,200 bar/17,400 psi

The instruments comprise of two conventional pressure balances (CPB5000 basic version) in the one enclosure. For the calibration of differential pressure gauges under a static pressure, the two systems are separated by a by-pass valve.

One of the systems is used to generate the static pressure with the second system generating the differential pressure (including static pressure). It is recommended that one of the sets of trim-masses is used for this (see Accessories).

The pneumatic base instrument version to 100 bar and the hydraulic version are fitted, as standard, with the patented ConTect quick-connect system. This enables a quick and safe replacement of the piston-cylinder system without any tools. The pneumatic instrument version with separator is fitted with a connection for the piston-cylinder system with M30 x 2 female threads.

The base instruments can also be used as individual instruments.

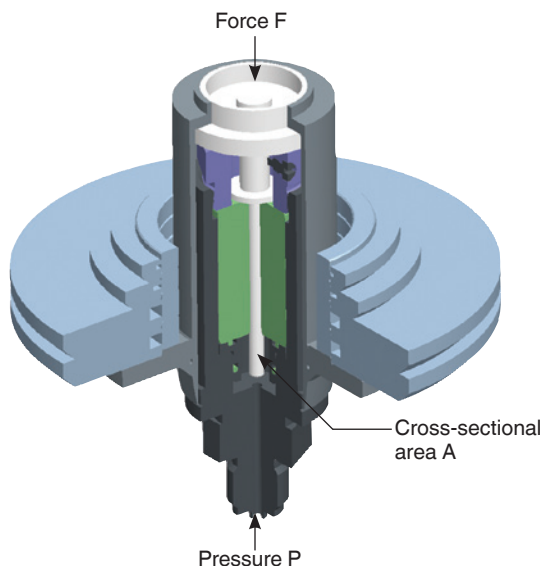

Piston-cylinder system model CPS5000

Tables of weights

The following tables show, for the respective measuring range, the number of masses within a set of masses, with their nominal mass values and the resulting nominal pressures.

Should you not operate the device under reference conditions

(ambient temperature 20 °C, air pressure 1013 mbar, relative humidity 40 %), the relevant corrections must be made.

The disc weights are manufactured, as standard, to the standard gravity (9.80665 m/s²) although they can be adjusted for any particular location.

Measuring range [bar]	Pneumatic models								Hydraulic models													
	0.03 ... 2		0.2 ... 10		0.4 ... 50		0.4 ... 100		0.2 ... 60		0.2 ... 100		1 ... 250		1 ... 400		2 ... 600		2 ... 1,000			
	Number	Nominal pressure per piece	Number	Nominal pressure per piece	Number	Nominal pressure per piece	Number	Nominal pressure per piece	Number	Nominal pressure per piece	Number	Nominal pressure per piece	Number	Nominal pressure per piece	Number	Nominal pressure per piece	Number	Nominal pressure per piece	Number	Nominal pressure per piece		
	bar		bar		bar		bar		bar		bar		bar		bar		bar		bar			
Piston	1	0.03	1	0.2	1	0.4	1	0.4	1	0.2	1	0.2	1	1	1	1	2	1	2	1	2	
Bell jar	1	0.16	1	0.8	1	4	1	4	1	1.6	1	1.6	1	8	1	8	1	16	1	16	1	16
Aluminium plate	1	0.01	1	0.05	1	0.25	1	0.25	1	0.1	1	0.1	1	0.5	1	0.5	1	1	1	1	1	1
Masses 4 kg	-	-	-	-	-	-	-	-	6	8	11	8	5	40	11	40	6	80	11	80	11	80
Masses 2 kg	-	-	-	-	-	-	5	10	2	4	2	4	2	20	2	20	2	40	2	40	2	40
Masses 1 kg	9	0.2	9	1	9	5	9	5	1	2	1	2	1	10	1	10	1	20	1	20	1	20
Masses 0.5 kg	1	0.1	1	0.5	1	2.5	1	2.5	1	1	1	1	1	5	1	5	1	10	1	10	1	10
Masses 0.2 kg	1	0.04	1	0.2	1	1	1	1	1	0.4	1	0.4	1	2	1	2	1	4	1	4	1	4
Masses 0.12 kg	1	0.024	1	0.12	1	0.6	1	0.6	-	-	-	-	-	-	-	-	-	-	-	-	-	-
Masses 0.1 kg	1	0.02	1	0.1	1	0.5	1	0.5	1	0.2	1	0.2	1	1	1	1	1	2	1	2	1	2
Masses 0.07 kg	1	0.014	1	0.07	1	0.35	1	0.35	-	-	-	-	-	-	-	-	-	-	-	-	-	-
Masses 0.05 kg	1	0.01	1	0.05	1	0.25	1	0.25	1	0.1	1	0.1	1	0.5	1	0.5	1	1	1	1	1	1

Measuring range [psi]	Pneumatic models										Hydraulic models							
	0.435... 30		2.9 ... 150		5.8 ... 500		5.8 ... 1,000		5.8 ... 1,500		2.9 ... 1,000		14.5 ... 5,000		29 ... 10,000		29 ... 14,500	
	Number	Nominal pressure per piece	Number	Nominal pressure per piece	Number	Nominal pressure per piece	Number	Nominal pressure per piece	Number	Nominal pressure per piece	Number	Nominal pressure per piece	Number	Nominal pressure per piece	Number	Nominal pressure per piece	Number	Nominal pressure per piece
	psi		psi		psi		psi		psi		psi		psi		psi		psi	
Piston	1	0.435	1	2.9	1	5.8	1	5.8	1	5.8	1	2.9	1	14.5	1	29	1	29
Bell jar	1	2.22	1	11.1	1	55.5	1	55.5	1	55.5	1	23.1	1	115.5	1	231	1	231
Aluminium plate	1	0.22	1	1.1	1	5.5	1	5.5	1	5.5	1	1.1	1	5.5	1	11	1	11
Masses 3.5 kg	-	-	-	-	-	-	-	-	-	-	9	100	9	500	9	1000	14	1000
Masses 1.4 kg	5	4	5	20	-	-	5	100	8	100	1	40	1	200	1	400	1	400
Masses 1 kg	2	3	2	15	2	75	2	75	2	75	1	30	1	150	1	300	1	300
Masses 0.7 kg	4	2	4	10	4	50	4	50	9	50	2	20	2	100	2	200	2	200
Masses 0.35 kg	3	1	3	5	3	25	3	25	3	25	1	10	1	50	1	100	1	100
Masses 0.19 kg	1	0.548	1	2.74	1	13.7	1	13.7	1	13.7	-	-	-	-	-	-	-	-
Masses 0.175 kg	-	-	-	-	-	-	-	-	-	-	1	5	1	25	1	50	1	50
Masses 0.14 kg	1	0.4	1	2	1	10	1	10	1	10	1	4	1	20	1	40	1	40
Masses 0.12 kg	1	0.345	1	1.725	1	8.625	1	8.625	1	8.625	-	-	-	-	-	-	-	-
Masses 0.07 kg	1	0.2	1	1	1	5	1	5	1	5	1	2	1	10	1	20	1	20

Specifications

Model CPB5000DP

Version		pneumatic					
Measuring range ^{1) 6)}	bar ²⁾	0.03 ... 2	0.2 ... 10	0.4 ... 50	0.4 ... 100		
Required masses	kg	10	10	10	20		
Smallest step	bar ³⁾	0.01	0.05	0.25	0.25		
Sensitivity ⁴⁾	mbar	0.002	0.01	0.05	0.05		
Nominal cross-sectional area of the piston	cm ²	5	1	0.2	0.2		
Version		pneumatic					
Measuring range ^{1) 6)}	psi ²⁾	0.435 ... 30	2.9 ... 150	5.8 ... 500	5.8 ... 1,000	5.8 ... 1,500	
Required masses	kg	10	10	7	13	20	
Smallest step	psi ³⁾	0.2	1	5	5	5	
Sensitivity ⁴⁾	psi	0.00003	0.00015	0.00075	0.00075	0.00075	
Nominal cross-sectional area of the piston	cm ²	5	1	0.2	0.2	0.2	
Version		hydraulic					
Measuring range ^{1) 6)}	bar ²⁾	0.2 ... 60	0.2 ... 100	1 ... 250	1 ... 400	2 ... 600	2 ... 1,000
Required masses	kg	30	50	25	40	30	50
Smallest step	bar ³⁾	0.1	0.1	0.5	0.5	1	1
Sensitivity ⁴⁾	mbar	0.04	0.04	0.2	0.2	0.4	0.4
Nominal cross-sectional area of the piston	cm ²	0.5	0.5	0.1	0.1	0.05	0.05
Version		hydraulic					
Measuring range ^{1) 6)}	psi ²⁾	2.9 ... 1,000	14.5 ... 5,000	29 ... 10,000	29 ... 14,500		
Required masses	kg	34	34	34	50		
Smallest step	psi ³⁾	2	10	20	20		
Sensitivity ⁴⁾	psi	0.006	0.003	0.006	0.006		
Nominal cross-sectional area of the piston	cm ²	0.5	0.1	0.05	0.05		
Accuracy ⁷⁾	% of reading	Proportion of static pressure: 0.0001 Proportion of differential pressure: 0.015 / optional: 0.008 ⁵⁾ depending on the measuring range; corresponds to the sensitivity of the piston					
Lower limiting value of the measurement uncertainty							
Instrument base version							
Pneumatic		up to a max. 100 bar/1,500 psi; with booster pump, spindle pump and connection for external supply					
Pneumatic, with separator		up to a max. 400 bar/5,000 psi; for external supply with integrated gas to oil separator for use with hydraulic piston with M30 x 2 connection					
Hydraulic		up to a max. 1,000 bar/14,500 psi; with internal pressure generation up to a max. 1,200 bar/17,400 psi on request					
Connection to the piston-cylinder system		ConTect quick-connector on pneumatic and hydraulic instrument base versions M30 x 2 male thread on pneumatic instrument base version with separator					
Test item connection		2 pieces, G ½ B female thread quick-connector as standard, freely rotating, changeable, (for other threaded inserts, see accessories)					
Pressure transmission medium	pneumatic	clean, dry, non corrosive gases (e.g. air or nitrogen)					
	hydraulic	Operating fluid (1 litre is included in delivery), other media on request					
Oil reservoir	cm ³	250					
External pressure connection		6 mm SWAGELOK [®] tube fitting; max. 110 % of the assigned measuring range; only with pneumatic and pneumatic with separator instrument base versions					
Material							
Piston		tungsten carbide					
Cylinder		tungsten carbide					
Mass-set		stainless steel 1.4305 and aluminium, non-magnetic					
Piping in instrument base		pneumatic: stainless steel 1.4571, 3 x 1 mm hydraulic: stainless steel 1.4404, 6 x 2 mm					
Operating temperature	°C	18 ... 28					
Weight							
Instrument base, pneumatic	kg	34.0					
Instrument base, pneumatic with separator	kg	32.0					
Instrument base, hydraulic	kg	38.5					
Piston-cylinder system	kg	1.5 / 5.7 (incl. bell jar and aluminium plate in optional storage case); 2 systems required					
BAR basic set of masses, pneumatic	kg	32.4 (incl. 2 carrying case)					
BAR extension set of masses, pneumatic	kg	28.0 (incl. 2 carrying cases)					
BAR basic set of masses, hydraulic	kg	72.0 (incl. 2 carrying cases)					

Specifications		Model CPB5000DP
BAR extension set of masses, hydraulic	kg	48.0 (incl. 2 carrying cases)
PSI basic set of masses, pneumatic	kg	25.0 (incl. 2 carrying cases)
PSI extension set of masses 1, pneumatic	kg	22.0 (incl. 2 carrying cases)
PSI extension set of masses 2, pneumatic (only for 1,500 psi)	kg	37.0 (incl. 2 carrying cases)
PSI basic set of masses, hydraulic	kg	84.0 (incl. 2 carrying cases)
PSI extension set of masses, hydraulic	kg	43.0 (incl. 2 carrying cases)
Dimensions		
Instrument base	mm	800 (W) x 375 (D) x 265 (H), for details, see technical drawings
Carrying case for basic set of masses	mm	400 (W) x 310 (D) x 310 (H)
Carrying case for extension set of masses	mm	215 (W) x 310 (D) x 310 (H)
Carrying case for piston-cylinder system (optional)	mm	300 (W) x 265 (D) x 205 (H)
CE conformity		
Pressure equipment directive		97/23/EC (Module A) only for 1,200 bar/17,400 psi version
Calibration		Factory calibration certificate / optional: DKD/DAkkS calibration certificate

- 1) Measuring range = static pressure + differential pressure
- 2) Theoretical starting value; corresponds to the pressure value generated by the piston (by its own weight). To optimise the operating characteristics more weights should be loaded.
- 3) The smallest pressure change value that can be achieved based on the standard weight set. To reduce this, a set of trim-masses is also available.
- 4) The sensitivity is the threshold of the measuring system. It is the pressure value of the smallest mass-addition, which brings the piston-cylinder system clearly and reproducibly out of balance.
- 5) Measurement uncertainty assuming reference conditions (ambient temperature 20 °C, air pressure 1013 mbar, relative humidity 40 %). For operation without a CalibratorUnit, corrections must be made if required.
- 6) Others on request
- 7) The accuracy of the differential pressure is determined in accordance with the following calculation basis.

Calculation of the measurement uncertainty

The accuracy of the differential pressure is the quadratic sum of the percentage of static pressure u_{stat} . (normally distributed) and the percentage of the differential pressure value u_{diff} . (normally distributed). In this way, the minimum values of each of the individual components are taken into account. What is calculated is the expanded uncertainty U ($k = 2$), in which the measurement lies with a probability of 95 %.

The measurement uncertainty is calculated as per the following equation:

$$U = k \cdot \sqrt{(u_{stat} / 2)^2 + (u_{diff} / 2)^2} \quad (k = 2 \text{ for } 95 \%)$$

Example 1:

Measuring range of piston-cylinder system: 10 bar
 Accuracy of the piston-cylinder system: 0.015 %
 Static pressure: 5 bar
 Differential pressure measured value: 100 mbar

	Measurement uncertainty	Lower limiting value of the measurement uncertainty
Proportion of static pressure	0.0001 % of 5 bar = 0.005 mbar	0.01 mbar
Proportion of differential pressure	0.015 % of 100 mbar = 0.015 mbar	0.01 mbar
Overall accuracy	$\pm 2 \cdot \sqrt{(0.01 \text{ mbar}/2)^2 + (0.015 \text{ mbar}/2)^2} = 0.018 \text{ mbar}$ which corresponds to ± 0.018 % of reading	

Example 2:

Measuring range of piston-cylinder system: 250 bar
 Accuracy of the piston-cylinder system: 0.008 %
 Static pressure: 200 bar
 Differential pressure measured value: 2 bar

	Measurement uncertainty	Lower limiting value of the measurement uncertainty
Proportion of static pressure	0.0001 % of 200 bar = 0.2 mbar	0.2 mbar
Proportion of differential pressure	0.008 % of 2 bar = 0.16 mbar	0.2 mbar
Overall accuracy	$\pm 2 \cdot \sqrt{(0.2 \text{ mbar}/2)^2 + (0.2 \text{ mbar}/2)^2} = 0.283 \text{ mbar}$ which corresponds to ± 0.014 % of reading	

Dimensions in mm

The drawing shows a pneumatic CPB5000DP instrument base. The hydraulic version does not differ from it dimensionally, only in the arrangement of the control elements.

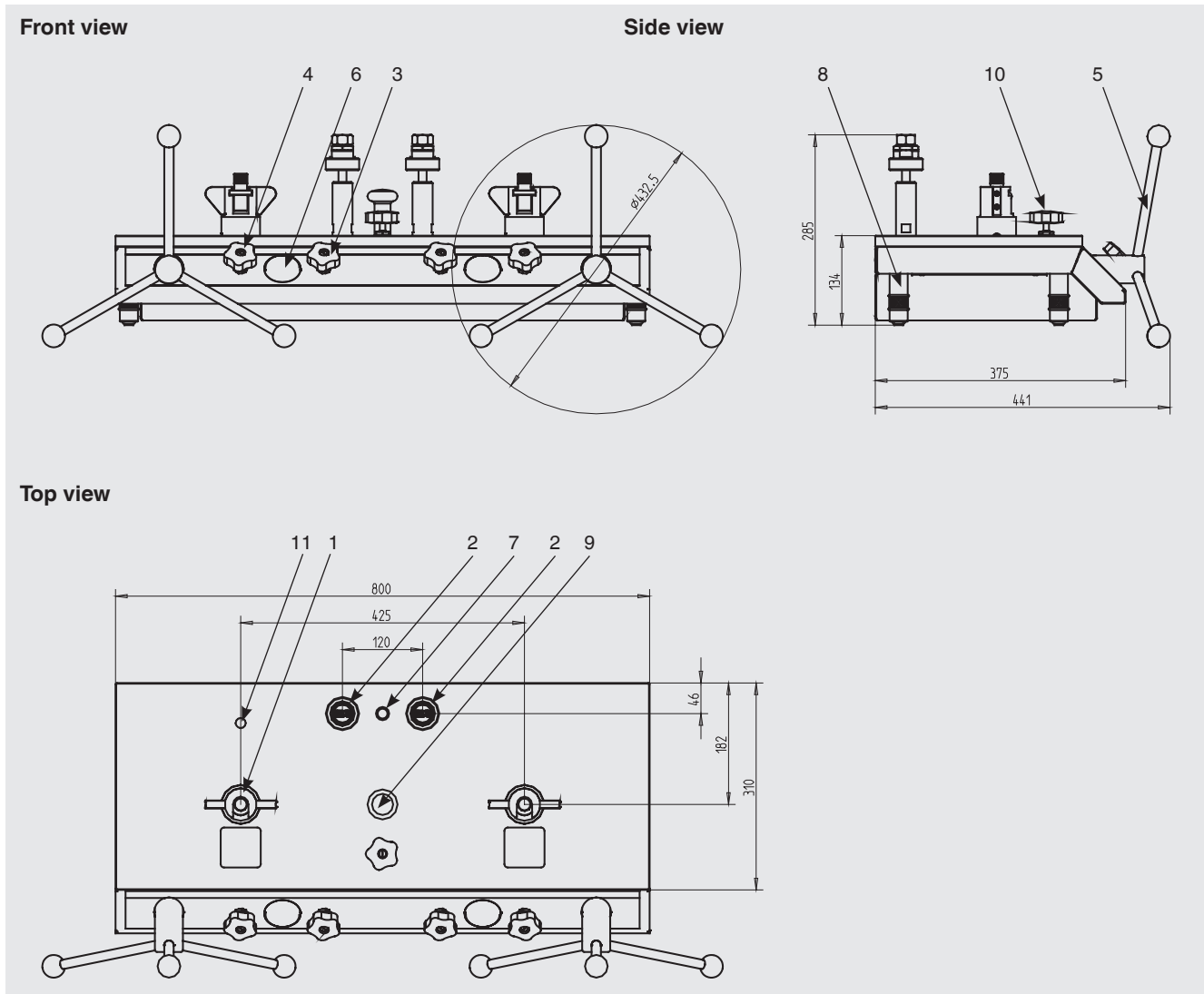

Test item connector

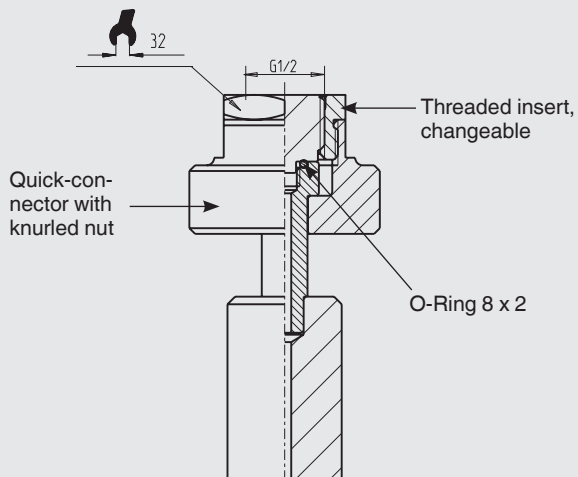

- (1) Fixture for piston-cylinder system
- (2) Test item connection
- (3) Inlet valve (only on pneumatic versions)
- (4) Outlet valve
- (5) Spindle pump with star handle, removable
- (6) Test pressure gauge (only to a max. 1,000 bar/14,500 psi)
- (7) Water level
- (8) Rotatable feet
- (9) Booster pump
- (10) Bypass valve
- (11) Threaded drain plug for oil reservoir (only on hydraulic versions)

CalibratorUnit model CPU5000

The CPU5000 CalibratorUnit is a compact tool for use with a pressure balance. In particular when highly-accurate measuring values, with measurement uncertainties of less than 0.025 %, are required, complicated mathematical calculations and corrections are necessary. With the CPU5000, all critical ambient parameters can be registered and automatically corrected.

Further specifications on the CPU5000 CalibratorUnit can be found in data sheet CT 35.01.

Accessories

Set of trim-masses

The weights included in the standard scope of delivery are ideally suited for everyday use. If you would like to generate intermediate values, however, we recommend using a set of Class F1 trim-masses, with the following weights:

1 x 50 g / 2 x 20 g / 1 x 10 g / 1 x 5 g / 2 x 2 g / 1 x 1 g /
 1 x 500 mg / 2 x 200 mg / 1 x 100 mg / 1 x 50 mg /
 2 x 20 mg / 1 x 10 mg / 1 x 5 mg / 2 x 2 mg / 1 x 1 mg

Set of adapters for quick connector

As a standard, the pressure balance is equipped with a quick connector for connecting the test item. For this purpose, various threaded adapters, which can be easily changed, are available:

- Set of adapters: G ¼, G ⅜, ½ NPT, ¼ NPT and M20 x 1.5
- Set of NPT adapters: ⅜ NPT, ¼ NPT, ⅝ NPT and ½ NPT

Additionally the sets of adapters include spare O-rings as well as a spanner with SW32 flats and SW14 flats, for changing the adapters.

Other threaded inserts are available on request.

Order variants

CPU5000 base packet (processor only)

- Calculation of the mass-loads
- Manual input of all parameters

Sensor package for measuring of:

- Ambient temperature, air pressure, air humidity and piston temperature

Multimeter package

- DC 24 V power supply and measurement of output signal (V, mA) incl. conversion into pressure values

Piston position display

- Contact-free measuring of piston position



Set of trim-masses



Set of adapters

Designation / Variant	Order No.
Set of trim-masses (1 mg up to 50 g), Class F1	7093874
Set of adapters for quick-connector in case with G ¼, G ⅜, ½ NPT, ¼ NPT and M20 x 1.5 threaded inserts for insertion in the knurled nut on the test item connector	2036941
Set of "NPT" adapters for quick-connector in case with ⅜ NPT, ¼ NPT, ⅝ NPT and ½ NPT threaded inserts for insertion in the knurled nut on the test item connector	12563626
90° angle connection, for test item with back mounting connection	1564838
Purifier, max. 1,000 bar	1565389
Dirt trap, -1 ... +1,000 bar, volume 0.2 litres	2015820
Dirt trap, -1 ... +1,000 bar, volume 0.03 litres	2015714
O-Ring set consisting of 5 pcs. 8 x 2 and 5 pcs. 4 x 2.2	12328562
Operating fluid for CPB5000 up to a max. 4,000 bar, 1 litre	2099882
Cleaning set for ConTect systems, pneumatic	12485943
Cleaning set for ConTect systems, hydraulic	12481425

Scope of delivery

- Instrument base
- Booster pump
- Spindle pump for pressure generation/fine adjustment
- Piston adapter with ConTect quick-connector (on pneumatic and hydraulic instrument base)
- Piston adapter with M30 x 2 female thread (on pneumatic instrument base with separator)
- 2 quick connectors for test items
- 2 piston-cylinder systems with bell jars
- 2 basic sets of adapters in carrying case
- 2 extension sets of masses in carrying case (depending on the measuring range)
- Set of masses manufactured to standard gravity (9.80665 m/s²)

- Operating fluid 1.0 litre (only for hydraulic version) or 0.25 litre (for separator version)
- Operating instructions in German and English language
- Factory calibration certificate

Options

- System with increased accuracy up to 0.008 %
- Storage case for piston-cylinder system
- Set of masses manufactured to local gravity
- DKD/DAkkS calibration certificate

Further pressure balances within our calibration technology programme

Pressure balance model CPB3000

Measuring ranges:

- hydraulic 60 bar to 1,000 bar or
1,000 psi to 14,500 psi, respectively

Accuracy: 0.025 % of reading

Specifications see data sheet CT 31.05



Pressure balance model CPB3000

Pressure balance model CPB5000

Measuring ranges:

- pneumatic -1 bar to +100 bar, or
-14 psi to +1,500 psi, respectively
- hydraulic 60 bar to 1,000 bar or
1,000 psi to 14,500 psi, respectively

Accuracy: 0.015 % of reading
0.008 % of reading (optional)

Specifications see data sheet CT 31.01



Pressure balance model CPB5000

Pressure balance for high pressure model CPB5000HP

Measuring ranges:

- hydraulic 2,500 bar, 4,000 bar or 5,000 bar or
40,000 psi, 60,000 psi or 70,000 psi,
respectively

Accuracy: 0.025 % of reading
0.02 % of reading (optional)

Specifications see data sheet CT 31.51



Pressure balance for high pressure model CPB5000HP

© 2010 WIKA Alexander Wiegand SE & Co. KG, all rights reserved.
The specifications given in this document represent the state of engineering at the time of publishing.
We reserve the right to make modifications to the specifications and materials.