

OBSOLETE

Digital pressure balance Model CPD8000



WIKA data sheet CT 32.04



for further approvals
see page 7

Applications

- High-level digital primary standard
- Reference instrument for calibration laboratories and high-end sensor production for the testing, adjustment and calibration of pressure measuring instruments
- Complete, stand-alone system, also suitable for on-site use

Special features

- Absolute and gauge pressure
- Unique working principle
- 15 measuring ranges up to 50 MPa
- Total measurement uncertainty down to 20 ppm of reading
- Ideal for automatic calibration systems



Model CPD8000-AL digital pressure balance, fitted with low-pressure measuring head

Description

Reference primary standards

Pressure balances are high-precision fundamental pressure standards that define the derived unit of pressure directly from the fundamental units of mass, length and time following the formula $p = F/A$.

The model CPD8000 digital pressure balance is a worldwide exclusivity combining two high-level technologies:

- High-end piston-cylinder systems, whose effective area (A) converts the pressure into the respective force.
- High-accuracy force cell which measures the force F.

CPD8000 is defined as a digital pressure balance and is thus a high-precision pressure measurement standard.

Functionality

The CPD8000 measuring concept is a primary principle. It combines the measurement uncertainty and reliability of fundamental pressure standards with the ease of use of automatic digital pressure measuring instruments.

Easy to use

The model CPD8000 offers the same high measurement uncertainty as a high-end pressure primary standard with the benefits of:

- Mass load not necessary
- Built-in reference mass for auto calibration
- Displaying and digital transmission of fully corrected reference pressure

The working principle

- The pressure is applied on the effective area of the piston and turned into a proportional force. The force is transferred to the measuring-force cell.
- The measuring-force cell continuously measures and calculates the pressure-generated force.
- A microprocessor converts the measured force to the measurement parameter pressure and corrects the environmental influences.

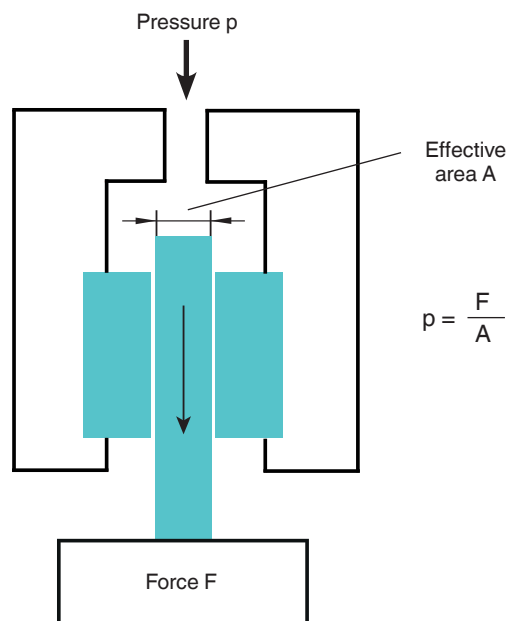

Model CPD8000 basic principle

Gauge and absolute pressure

The model CPD8000 is available in two versions:

CPD8000-GH (gauge pressure)

Available measuring ranges up to 500 bar (5.000 psi oder 50 MPa) with atmospheric pressure reference.

CPD8000-AL and CPD8000-AH (gauge and absolute pressure)

Available measuring ranges up to 20 bar (2 MPa) in gauge mode and absolute pressure.

The installation of a measuring-force cell in a vacuum-sealed reference pressure chamber enables operation in gauge and absolute pressure mode. Continuous measuring process in absolute pressure is possible without interruption contrary to classic absolute pressure balances, where the reference vacuum has to be interrupted with each pressure change.

The measurement is placed under a reference vacuum chamber. Absolute pressure measurement is a simple and fast solution. It is capable to operate in an absolute pressure mode without interrupting the vacuum between each pressure point, as it is with the classical pressure balances.



Model CPD8000-GH



Model CPD8000-AL or CPD8000-AH

General assembly

CPD8000's measurement quality and long-term performance are based on five key concepts.

Piston-cylinder measuring system

Key element

The role of the piston-cylinder system is to precisely convert the pressure into force. The quality of this transformation is due to its excellent geometry and very low sensitivity to external disturbances.

The Desgranges & Huot's piston-cylinder systems (PCUs) are manufactured in a special grade of tungsten carbide, which has been perfected for more than 50 years. The manufacturing tolerances are typically below 0.1 µm, promoting best possible sensitivity, linearity and repeatability.

Tungsten carbide has the advantage of minimal distortion under pressure and temperature. Therefore, the piston-cylinder system maintains the metrological qualities regardless of the operating conditions.

A large choice of pressure ranges

Desgranges & Huot manufactures 21 different piston-cylinder systems (6 for the CPD8000-AL/-AH, 15 for the CPD8000-GH).

For easier handling and assignment, the effective area of the piston-cylinder systems are dimensioned with a nominal conversion factor (Kn).

The measuring head

A comfortable unit

The measuring head contains the piston-cylinder systems. Trouble-free force transmission from the rotating piston to the measuring-force cell is ensured by the coupled drive system.

It is equipped with a 4-wire platinum resistance thermometer allowing for the necessary temperature measurement.

The coupling of the measuring head with the force cell allows for simple and fast exchange of the measuring heads.

The measuring cell

A force-transferring function

The electronic measuring-force cell has been developed for the highly accurate production of mass comparators.

It uses the MONOBLOC technology manufactured by electro erosion. This technology reflects the latest innovations realised in mechanics, electronics, computer science and opto-electronics, hence eliminating operations that require comprehensive maintenance.

The auto-calibrating function (ACF)

The CPD8000 force cell response may drift with time. This drift is a result of the change in the environmental parameters ambient temperature, relative humidity and atmospheric pressure.

The measuring-force cell is associated with an auto-calibrating function which, whenever necessary, enables easy application of a reference mass ($F = M \times g$) for recalibration purposes while the measuring head is connected.

Optionally a set of external standard masses can be used for linearisation of the measuring-force cell.

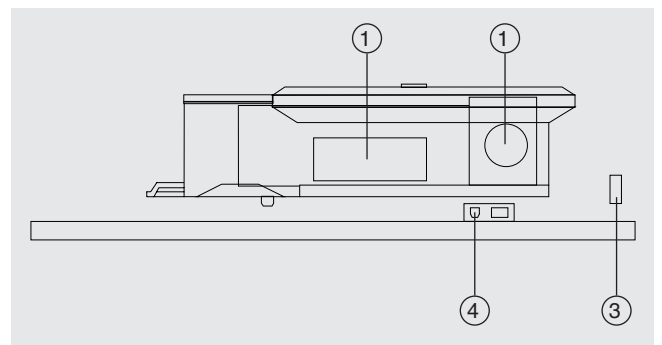

Basic principle of the auto-calibrating function (ACF)

- ① Measuring-force cell
- ② Internal standard mass
- ③ Computer connection
- ④ EMM sensors

The environment monitoring module (EMM)

In order to determine whether it is necessary to use the **ACF**, the CPD8000 is equipped with an environment monitoring module which consists of three sensors for ambient temperature, relative humidity and barometric pressure.

After the calibration, the **EMM** keeps on monitoring the evolution of the ambient conditions in real time.

If these conditions vary in proportions that might noticeably affect the measuring accuracy, the CPD8000 displays a warning flag. The user's attention is drawn to the fact that the **ACF** has to be activated in order to readjust the measuring instrument to the new operating conditions. The warning is also sent to the command software if the CPD8000 is operated from a remote computer.

Displayed pressure calculation

The pressure displayed by the CPD8000 is calculated according to the following formula:

$$P = Kn \times \frac{N}{N_k} \times \frac{g_l}{g_n} \times (1 - (\lambda_{PC} \times P)) \times (1 - \alpha_{PC} \times (t - 20)) \times \left(\frac{\rho_{ac} - \rho_m}{\rho_{an} - \rho_m} \right) + P_{Vac}$$

Legend:

- Kn** Specific coefficient of the piston-cylinder system
- N** Indication of the measuring-force cell in count
- N_k** Sensitivity of the measuring-force cell
- g_l** Local gravitational acceleration in m/s²
- g_n** Normal gravitational acceleration in m/s²
- λ_{PC}** Pressure-distortion coefficient of the piston-cylinder system
- α_{PC}** Thermal-dilation coefficient of the piston-cylinder system
- t** Temperature of the piston-cylinder system in °C
- ρ_{ac}** Air density during the adjustment of the measuring-force cell in kg m⁻³. This parameter is null when the CPD8000-A operates in absolute mode.
- ρ_m** Density of the adjustment mass in kg m⁻³
- ρ_{an}** Normal air density in kg m⁻³
- P_{Vac}** Residual gas pressure in the vacuum chamber

Variable parameters

The variable parameters affecting the calculation of the pressure are automatically measured and integrated in the expression of the pressure:

- Temperature of the piston-cylinder system (t)
- Ambient temperature ¹⁾
- Humidity ¹⁾
- Atmospheric pressure ¹⁾
- Residual vacuum (P_{Vide})

1) Defining the air density during the calibration (ρ_{ac})

The pressure is automatically converted into any of the common pressure units and the user has the possibility to configure the system to special units.

This rigorous metrology enables an ease of use as well as speed of measurement operation.

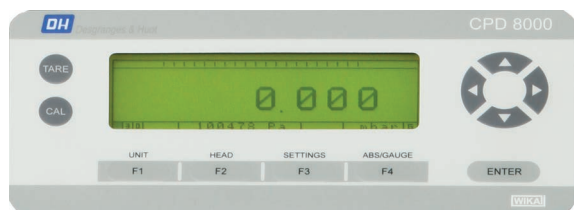

Display of the model CPD8000

Constant parameters

The constant parameters entering in the computing of pressure are stored in the memory of the CPD8000:

- Kn of the piston-cylinder system
- Sensitivity of the measuring-force cell (**N_k**)
- Normal gravitational acceleration (**g_n**)
- Local gravitational acceleration (**g_l**)
- Pressure-distortion coefficient of the piston-cylinder system (**λ_{PC}**)
- Thermal dilation coefficient of the piston-cylinder system (**α_{PC}**)
- Density of the calibration mass (**ρ_m**)
- Normal air density (**ρ_{an}**)

Some of these parameters are specific to each piston-cylinder system and are determined during the calibration. You can easily modify them if necessary. The parameters of six different piston-cylinder systems can be stored.

Measuring ranges

The pressure measuring ranges of the CPD8000 depend on the specific coefficient (Kn) of the piston-cylinder systems with which the measuring head is equipped.

The CPD8000 can be used with various measuring heads.

Measuring head	Pressure ranges	Resolution	Measurement uncertainty ¹⁾		Piston-cylinder system Kn	Usable medium
			Standard	Premium		
Absolute and gauge pressure with model CPD8000-AL and CPD8000-AH						
A01	0.001 mbar ... 1 bar	0.001 mbar	0.005 %	0.0025 %	0.1 bar/kg	Pure gas
A02	0.002 mbar ... 2 bar	0.002 mbar	0.005 %	0.0025 %	0.2 bar/kg	Pure gas
A03	0.005 mbar ... 5 bar	0.005 mbar	0.005 %	0.0025 %	0.5 bar/kg	Pure gas
A04	0.01 mbar ... 10 bar	0.01 mbar	0.005 %	0.0025 %	1 bar/kg	Pure gas
A05	0.02 mbar ... 20 bar	0.02 mbar	0.005 %	0.0025 %	2 bar/kg	Pure gas
Gauge pressure with model CPD8000-GH						
G01	0.001 mbar ... 1 bar	0.001 mbar	0.005 %	0.0025 %	0.1 bar/kg	Pure gas
G02	0.002 mbar ... 2 bar	0.002 mbar	0.005 %	0.0025 %	0.2 bar/kg	Pure gas
G03	0.005 mbar ... 5 bar	0.005 mbar	0.005 %	0.0025 %	0.5 bar/kg	Pure gas
G04	0.01 mbar ... 10 bar	0.01 mbar	0.005 %	0.0025 %	1 bar/kg	Lubricated gas
G05	0.02 mbar ... 20 bar	0.02 mbar	0.005 %	0.0025 %	2 bar/kg	Lubricated gas
G06	0.05 mbar ... 50 bar	0.05 mbar	0.005 %	0.0025 %	5 bar/kg	Lubricated gas
G07	0.1 mbar ... 100 bar	0.1 mbar	0.005 %	0.0025 %	10 bar/kg	Lubricated gas
G08	0.2 mbar ... 200 bar	0.2 mbar	0.005 %	0.003 %	20 bar/kg	Lubricated gas
G09	0.5 mbar ... 500 bar	0.5 mbar	0.005 %	0.0035 %	50 bar/kg	Lubricated gas
G20	0.0002 ... 200 psi	0.0002 psi	0.005 %	0.0025 %	20 psi/kg	Lubricated gas
G21	0.0005 ... 500 psi	0.0005 psi	0.005 %	0.0025 %	50 psi/kg	Lubricated gas
G22	0.001 ... 1,000 psi	0.001 psi	0.005 %	0.0025 %	100 psi/kg	Lubricated gas
G23	0.0025 ... 2,500 psi	0.0025 psi	0.005 %	0.003 %	250 psi/kg	Lubricated gas
G24	0.003 ... 3,000 psi	0.003 psi	0.005 %	0.003 %	300 psi/kg	Lubricated gas
G25	0.005 ... 5,000 psi	0.005 psi	0.005 %	0.003 %	500 psi/kg	Lubricated gas

1) The total measurement uncertainty is defined as the uncertainty in measurement attributed via the reference standard uncertainty, influence of environmental conditions, resolution of the instrument, repeatability and hysteresis characteristics during the measurement with the coverage factor (k = 2).

Other pressure ranges on request.

**Specifications
Model CPD8000**



Piston-cylinder system	
Material	Tungsten carbide
Poisson's ratio	0.218
Young's modulus	$6 \cdot 10^{11}$ N/m
Typical geometry researched	
Straightness	0.1 μ m (typical manufacturing tolerance)
Roundness	0.1 μ m (typical manufacturing tolerance)
Parallelism	0.1 μ m (typical manufacturing tolerance)
Clearance between the piston and the cylinder	0.2 ... 0.4 μ m according to the model
Stability of the effective area	≤ 1 ppm/year

Standard masses	
Internal masses	
Material	304L non-magnetic stainless steel
Mass density	7,900 kg/m ³ ± 10 %
External optional calibration masses	
Material	304L non-magnetic stainless steel
Mass density	7,920 kg/m ³ ± 10 %
Composition of the set	5 x 2 kg (5 x 4.4 lbs)

Base instrument				
Case				
Dimension (L x W x H)	530 x 400 x 320 mm (20.87 x 15.75 x 12.60 in)			
Weight	20 kg (44.1 lbs)			
Display				
Screen	LC display back-lighting graphic screen with contrast setting			
Indication	Pressure display in 12 pressure units and a user unit EMM parameter display Permanent display of the residual gas pressure			
Front foil				
TARE button CAL button, automatic calibration function (ACF)				
Sensor specifications				
Maximum overpressure	110 % FS			
Pressure transmission medium	Clean, dry, non-corrosive gases			
Voltage supply				
Power supply	AC 110 ... 240 V, 50/60 Hz			
Power consumption	60 ... 80 VA			
Environmental measuring module (EMM)		Sensor type	Accuracy	Alarm setting
Ambient temperature	4-wire Pt100	± 0.2 °C	± 2 °C	
Relative humidity	Capacitive sensor	± 5 % r. h.	± 20 % r. h.	
Atmospheric pressure	Strain sensor	± 2 mbar	± 10 mbar	
PCA temperature	DIN 43760 4-wire Pt100	± 0.1 °C	N/A	
Residual vacuum		Pirani gauge ≥ 1 Pa ± 1 E ⁻⁴		

Base instrument	
Researched metrological specifications	
Linearity	2 E ⁻⁶ FS
Hysteresis	2 E ⁻⁶ FS
Repeatability	≤ 5 E ⁻⁶ FS
Temperature effect	Full compensation
Measurement uncertainty	down to 25 ppm of reading, depending on the measuring range
Permissible ambient conditions	
Operating temperature	18 ... 28 °C (64 ... 82 °F)
Relative humidity	15 ... 85 % r. h. (non-condensing)
Communication	
Interface	RS-232-C
Sampling rate	100 ms

Approvals

Logo	Description	Country
	EU declaration of conformity <ul style="list-style-type: none"> ■ EMC directive EN 61326 emission (group 1, class B) and immunity (electrical equipment for measurement, control and laboratory use) ■ Low voltage directive ■ RoHS-directive 	European Union
	EAC <ul style="list-style-type: none"> ■ Electromagnetic compatibility ■ Low voltage directive 	Eurasian Economic Community
	KazInMetr Metrology, measurement technology	Kazakhstan
-	MTSCHS Permission for commissioning	Kazakhstan

Certificates

Certificate	
Calibration	Standard: COFRAC calibration certificate Option: LNE/PTB calibration certificate
Recommended recalibration interval	3 to 5 years (dependent on conditions of use)

Approvals and certificates, see website

Dimensions in mm

Model CPD8000-AL and CPD8000-AH

Side view (left)

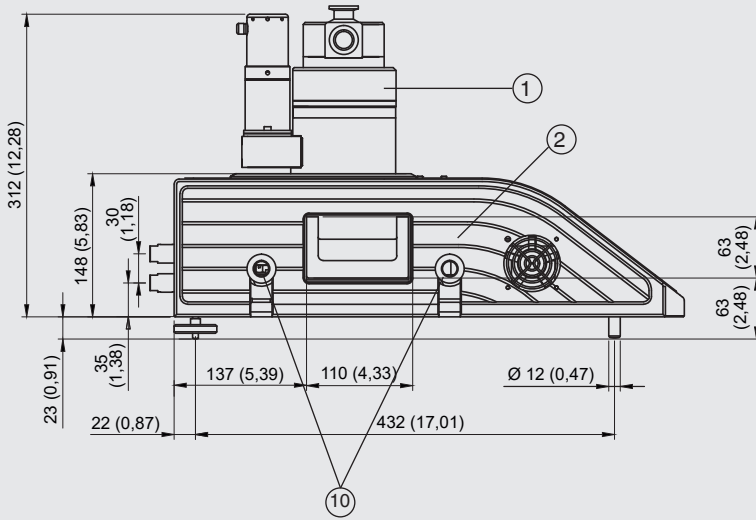

Rear view

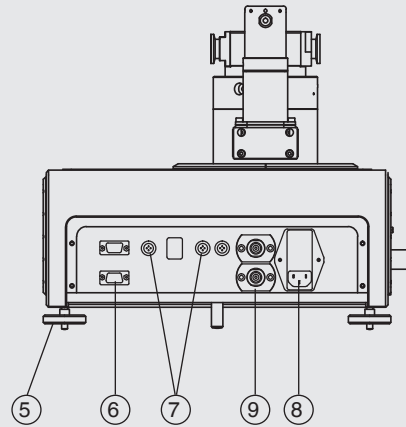

Top view

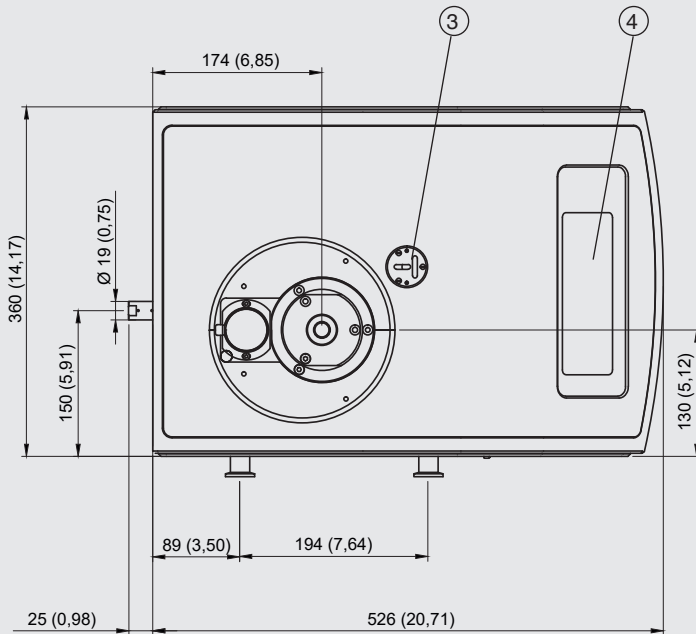

Front view

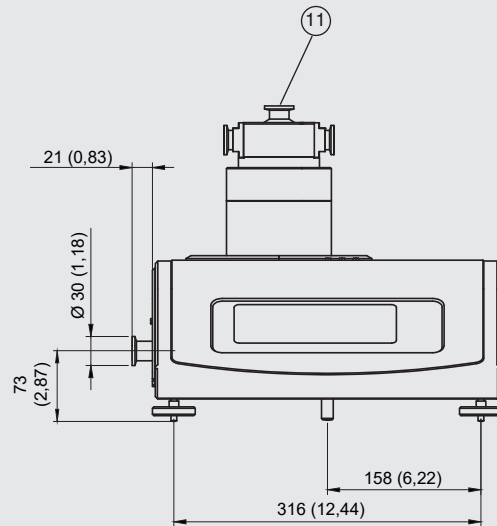

- ① Measuring head
- ② Measuring cell
- ③ Levels
- ④ Digital display
- ⑤ Levelling feet
- ⑥ COM port to PC
- ⑦ Connection port for motor and platinum resistance thermometer (PRT)
- ⑧ Mains supply
- ⑨ Connection for gas lubrication (for AH version)
- ⑩ Reference vacuum connections
- ⑪ Connection flange to the test item

Side view (left)

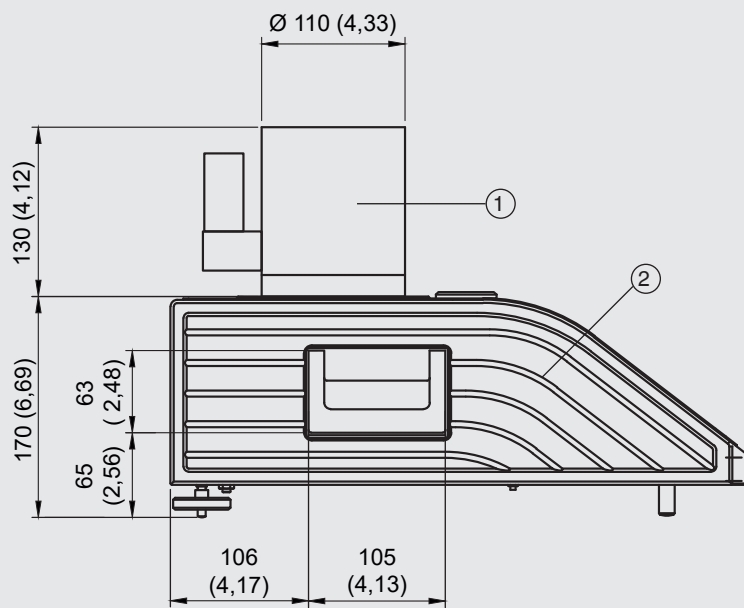

Rear view

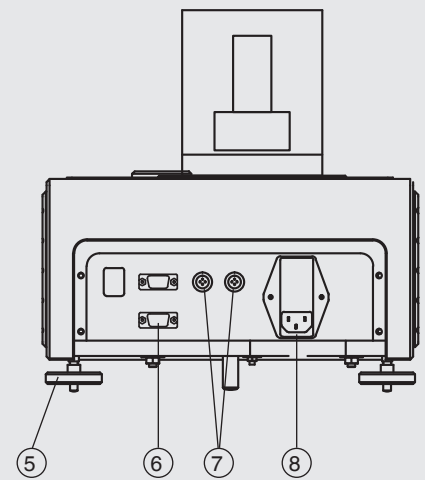

Top view

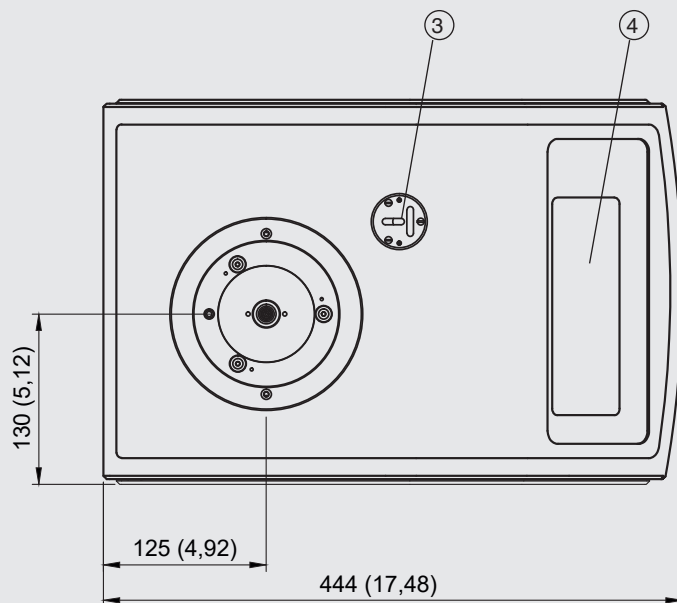

Front view

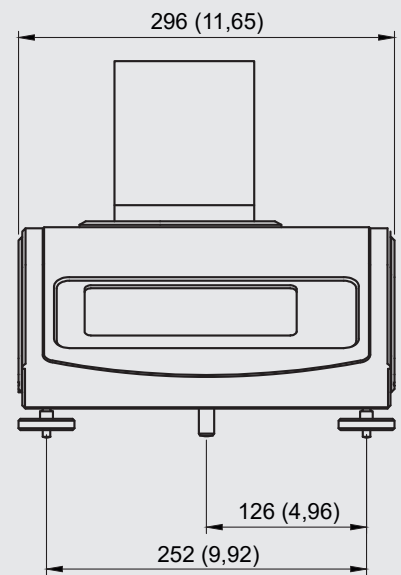

- ① Measuring head
- ② Measuring cell
- ③ Levels
- ④ Digital display
- ⑤ Levelling feet
- ⑥ COM port to PC

- ⑦ Connection port for motor and platinum resistance thermometer (PRT)
- ⑧ Mains supply

Remote control

All of the CPD8000 functions, even the **ACF** running command, can be executed from an external computer through serial interface (RS-232-C), which enables it to be integrated in an automatic calibrating system.

Maintenance

The CPD8000 is delivered with the operating instructions, accessories and tools allowing its general maintenance. No other maintenance is necessary if the standard is used in accordance with the routine instructions described in the operating instructions. Recalibration is recommended every five years depending on the operating conditions.

Calibration

All CPD8000 are delivered with a gauge COFRAC calibration certificate by Degranges & Huot. The COFRAC calibration guarantees the traceability of the measurements done by the CPD8000 to the national and international standards, and it takes into account:

- The **Kn** specific coefficient determination
- The automatic calibration function (**ACF**)

The uncertainty calculation presented in the certificate respects the ISO TAG4 and EAL recommendations and shows the enlarged measurement uncertainty of the CPD8000 with a coverage factor $k = 2$.

It takes into account the CPD8000's intrinsic measuring deviations, the uncertainty of the reference standards as well as the influence of the ambient conditions.

Option

By using a special adaptation kit, it is possible to use the measuring head of model CPD8000-GH with the CPD8000-AL/-AH. These heads can be used to work only in gauge mode but allow extending the range capability of the CPD8000-A up to 500 bar (50 MPa).

Conclusion

Due to the design and performance, the model CPD8000 digital pressure balance is unique in the world. The operations with the balance do not necessitate a bell to create the vacuum and masses load.

Connected to an automatic controller (CPC6000 or CPC8000), the CPD8000 enables performing fast calibrations, without having to break the vacuum between each pressure point, with a high metrological reliability.

These instruments are used by national laboratories, calibration labs, meteorology, the R&D laboratories, sensor manufacturers and aerospace or avoinic companies.

Summary of the functions

The CPD8000 has a great variety of functions aimed at facilitating its use and assuring the quality of its long-term operation:

- Menus in English, French, German and Spanish
- Saving of the metrological characteristics for 6 pressure ranges
- Overpressure visual and sound warning
- Mechanical protection against overpressure up to 110 %
- User-adjustable pressure stability criterion
- Choice between internal/external calibration
- Visual warning when the calibration of the force cell is necessary
- Temperature measurement at the piston-cylinder system with a platinum resistance thermometer (**PRT**)
- Auto-calibrating function (**ACF**) including the acquisition and correction calculation of the environment parameters (**EEM**)

Further pressure balances within our calibration technology programme

Primary-standard pressure balance, model CPB6000

Measuring ranges:

- Pneumatic up to 1,000 bar (14,500 psi)
- Hydraulic up to 5,000 bar (72,520 psi)
- Measurement uncertainty:** down to 0.002 % of reading, depending on model

For specifications see data sheet CT 32.01



Primary-standard pressure balance, series CPB6000

Primary-standard differential pressure balance, model CPB6000DP

Measuring range = (static pressure + differential pressure):

- Pneumatic up to 800 bar (11,600 psi)
- Measurement uncertainty:** 0.005 % of reading up to 0.002 % of reading (optional)

For specifications see data sheet CT 32.02



Primary-standard differential pressure balance, model CPB6000DP

Automatic pressure balance, model CPB8000

Measuring ranges:

- Pneumatic up to 1.000 bar (14.500 psi)
- Hydraulic up to 5.000 bar (72.520 psi)
- Measurement uncertainty:** 0.005 % of reading up to 0.003 % of reading (optional)

For specifications see data sheet CT 32.03



Automatic pressure balance, model CPB8000

WIKA-Cal calibration software

Easy and fast creation of a high-quality calibration certificate

The WIKA-Cal calibration software is used for generating calibration certificates or logger protocols for pressure measuring instruments and is available as a demo version for a cost-free download.

A template helps the user and guides him through the creation process of a document.

In order to switch from the demo version to a full version of the respective template, a USB key with the template has to be purchased.

The pre-installed demo version automatically changes to the selected full version when the USB key is inserted and is available as long as the USB key is connected to the computer.



- Creation of calibration certificates for mechanical and electronic pressure measuring instruments
- A calibration assistant guides you through the calibration
- Automatic generation of the calibration steps
- Generation of 3.1 certificates per DIN EN 10204
- Creation of logger protocols
- User-friendly interface
- Languages: German, English, Italian and more due with software updates

For further information see data sheet CT 95.10

Calibration certificates can be created with the Cal-Template and logger protocols can be created with the Log-Template.



Cal Demo

Generation of calibration certificates limited to 2 measuring points, with automatic initiation of pressures via a pressure controller.



Cal Light

Generation of calibration certificates with no limitations on measuring points, without automatic initiation of pressures via a pressure controller.



Log Demo

Creation of data logger test reports, limited to 5 measured values.



Log

Creation of data logger test reports without limiting the measured values.

Scope of delivery

- Digital pressure balance, model CPD8000 incl. transport case
- Measuring head
- Pt100 probe
- Cover for measuring head and measuring cell
- Power cord
- RS-232 interface cable
- Set of accessories for standard operation of the CPD8000
- Operating instructions
- COFRAC calibration certificate

Options

- Premium uncertainty incl. LNE/PTB calibration certificate

Ordering information

Model / Base / Head with piston-cylinder system / Calibration for piston effective area gauge / Calibration for piston effective area absolut / Mass set / Motor controller / Vacuum pump / Additional approvals / Additional order information

© 05/2014 WIKA Alexander Wiegand SE & Co. KG, all rights reserved.
The specifications given in this document represent the state of engineering at the time of publishing.
We reserve the right to make modifications to the specifications and materials.

