

# Monoblock With flange connection Model IBF1

WIKA data sheet AC 09.30

EAC

## Applications

- Oil and gas industry, chemical and petrochemical industries, power plants
- For gaseous and liquid aggressive media that are highly viscous or crystallising, also in aggressive environments
- Direct connection of pressure measuring instruments to flanged pipelines or vessels without interface valves
- Shut-off valve with venting function as tapping point for instruments
- For mounting to level indicators or differential pressure instruments in level measurement

## Special features

- Increased safety with metal enclosed valve seats and double valve body seal
- High-quality machining guarantees smooth operation with low torque and low wear
- Leak-tested tightness in accordance with BS6755 / ISO 5208 leakage rate A
- Customisable arrangement with ball and needle valves
- Customer-specific measuring arrangement with valves (instrument hook-up) on request

## Description

The monoblock has been designed to meet the requirements of the process industry, especially for natural gas and aggressive media applications. The compact design integrates a shut-off valve to separate the process from the instrument side.

For applications with liquid or dirty media, ball valves are recommended due to easy cleaning of the straight-through internal bore.

The one-piece case minimises the number of leakage points and thereby reduces the risk of media escaping into the environment. The valve seat design and the redundant seals



**Fig. left: Process connection: Flange, instrument connection: ½ NPT female**

**Fig. right: Process and instrument connection: Flange**

Configurator



Standard articles



of the valve body ensure high durability and tightness. In case the soft valve seat fails, the metal-to-metal seat will ensure that the valve can still be operated and set to a safe position. The tightness is guaranteed for the connection between the process and the measuring instrument and towards the atmosphere.

The super-finished machining of the internal parts allows a very smooth and precise operation, even at high pressures and after long periods without valve operation. The surface finish helps to prevent corrosion with aggressive media and makes it easier to clean.

# Specifications

Monoblock, model IBF1	
<b>Standards used</b>	
Design	<ul style="list-style-type: none"> <li>■ EEMUA publication 182, specification for integral block-and-bleed valve manifolds</li> <li>■ ASME B16.34, valves - flanged, threaded and welding end</li> <li>■ ASME BPVC section VIII, rules for construction of pressure vessels division 1</li> <li>■ ASME B31.1, power piping</li> <li>■ ASME B31.3, process piping</li> <li>■ ISO 17292, metal ball valves for petroleum, petrochemical and allied industries</li> <li>■ MSS SP-99, valves for measuring instruments</li> <li>■ ASME B16.5, pipe flanges and flange fittings</li> <li>■ ASME B1.20.1, pipe threads, general purpose (inch)</li> </ul>
Tests	<ul style="list-style-type: none"> <li>■ API 598, valve inspection and testing</li> <li>■ ISO 5208, pressure testing of metallic valves with leakage rate A</li> <li>■ MSS SP-61, pressure testing of valves</li> <li>■ DIN EN 12266-1, pressure tests, test procedures and acceptance criteria for industrial valves</li> <li>■ API607/API6FA/ISO 10497 fire test for valves</li> </ul>
Material requirement	<ul style="list-style-type: none"> <li>■ NACE MR0175 / ISO 15156, use in H<sub>2</sub>S-containing environments in oil and gas production</li> <li>■ NORSOK M-630, specification for use in pipelines (Norway)</li> </ul>
Marking	ASME B16.34, valves - flanged, threaded and welding end
<b>Pressure-temperature limits (for diagram, see page 5)</b>	The limits for operating pressure and temperature depend on the sealing material.
<b>Valve type (see next page)</b>	The shut-off valve can be defined as a ball valve or as a needle valve with OS&Y bonnet.
<b>Process connection</b>	<ul style="list-style-type: none"> <li>■ Flange ½" ... 2" / class 150 ... class 2500, following ASME B16.5</li> <li>■ Flange DN 15 ... DN 25 / PN 16 ... PN 100, following EN 1092-1</li> </ul>
<b>Surface roughness Ra of the sealing face</b>	
Following ASME B16.5	<ul style="list-style-type: none"> <li>■ RF: 3.2 ... 6.3 µm [125 ... 250 µin] (spiral surface)</li> <li>■ RJ: 1.6 µm [63 µin]</li> </ul>
Following EN 1092-1	<ul style="list-style-type: none"> <li>■ Form B1: 3.2 ... 6.3 µm [125 ... 250 µin]</li> <li>■ Form B2: 0.8 ... 3.2 µm [32 ... 125 µin]</li> </ul>
<b>Instrument connection</b>	<ul style="list-style-type: none"> <li>■ ½ NPT female, axial</li> <li>■ ½ NPT female, swivel adapter, axial</li> <li>■ G ½ female, swivel adapter, axial</li> <li>■ Flange connection</li> </ul>
<b>Vent connection</b>	<ul style="list-style-type: none"> <li>■ Without</li> <li>■ ½ NPT female, plug screw is included in delivery, though not pre-fitted.</li> <li>■ ½ NPT female, with vent screw</li> <li>■ ¼ NPT female, plug screw is included in delivery, though not pre-fitted</li> </ul>
<b>Anti-tamper version</b>	<ul style="list-style-type: none"> <li>■ Without</li> <li>■ With padlock</li> </ul>

## Functional diagram

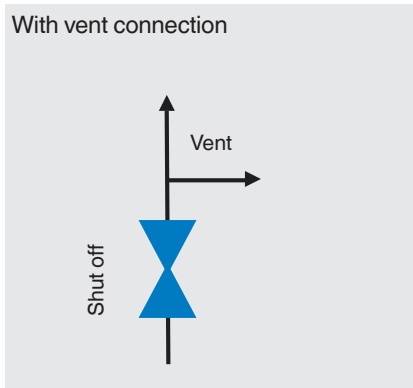
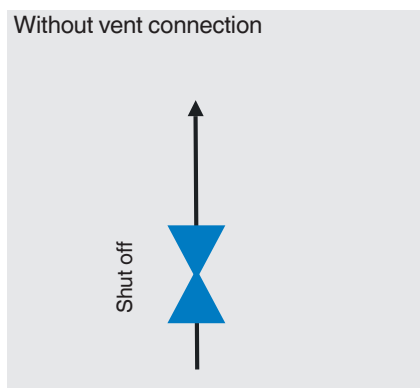

## Materials

### Wetted parts

Valve body and fittings, valve seat, valve stem, bonnet body, spindle tip	<ul style="list-style-type: none"> <li>■ Stainless steel 316L (standard)</li> <li>■ Duplex F51 (1.4462)</li> <li>■ Super Duplex F55 (1.4501)</li> <li>■ Hastelloy C276 (2.4819)</li> <li>■ Monel 400 (2.4360)</li> <li>■ Stainless steel 6Mo (1.4547)</li> <li>■ Alloy 625 (2.4856)</li> <li>■ Alloy 825 (2.4858)</li> </ul>
Sealing <sup>1)</sup>	<ul style="list-style-type: none"> <li>■ PEEK (ball valve seat), temperature range: -55 ... +260 °C [-67 ... +500 °F]</li> <li>■ RTFE (ball valve seat), temperature range: -55 ... +204 °C [-67 ... +400 °F]</li> <li>■ Graphite (needle valve sealing packing), temperature range: -55 ... +538 °C [-67 ... +1,000 °F]</li> </ul>

### Non-wetted parts

Bonnet, valve spindle, locking plate, locking pin, product label, screws	Stainless steel
Lever handle	Stainless steel, PVC coated
T-bar handle	Stainless steel

1) Other materials available on request

## Ball valve

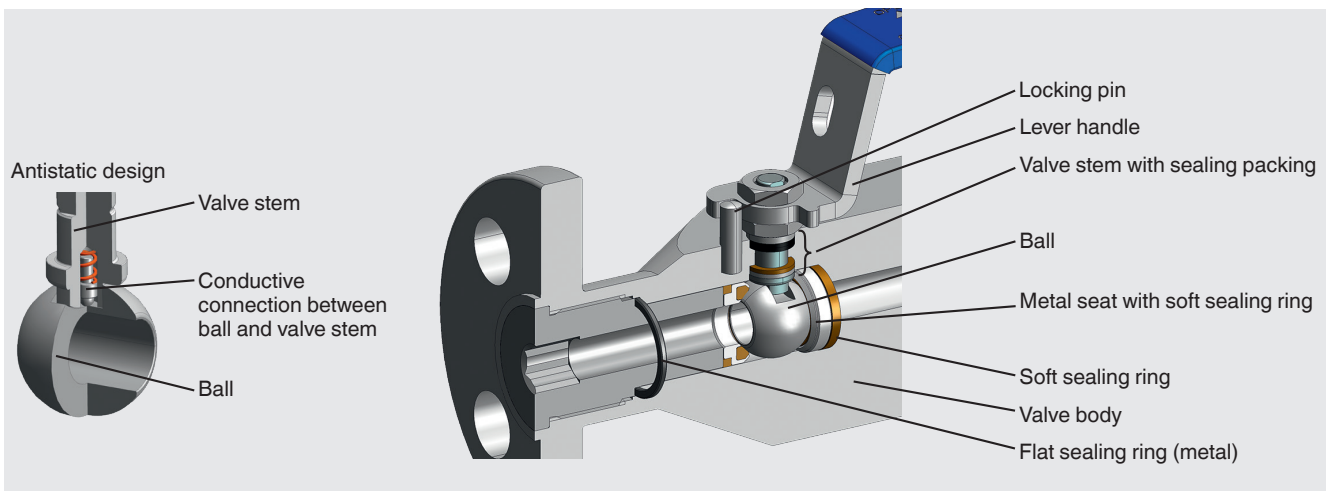

## Needle valve with OS&Y bonnet

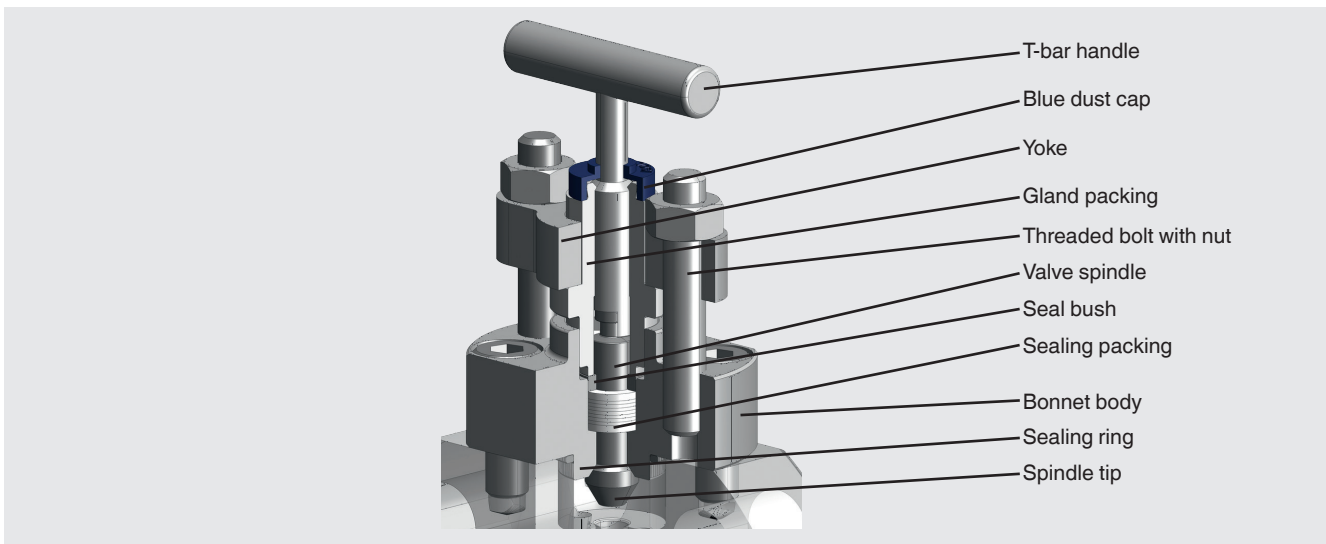

Specification	Ball valve	Needle valve with OS&Y bonnet
<b>Design</b>	<ul style="list-style-type: none"> <li>■ Antistatic design</li> <li>■ Blow-out-safe valve stem</li> <li>■ Self-relieving valve seats</li> </ul>	<ul style="list-style-type: none"> <li>■ Non-rotating spindle tip</li> <li>■ Blow-out proof spindle tip</li> <li>■ Back seat design</li> <li>■ Metal-to-metal seat</li> </ul>
<b>Valve bore size</b>	10 mm [0.394 in]	8 mm [0.315 in]

**Anti-tamper version with padlock**

Ball valve



**Anti-tamper version with padlock**

Needle valve with OS&Y bonnet

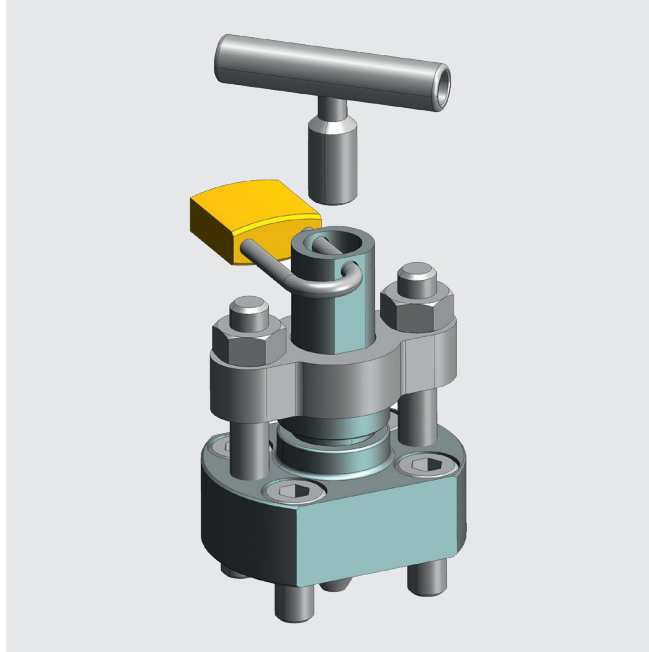

## Pressure-temperature diagram

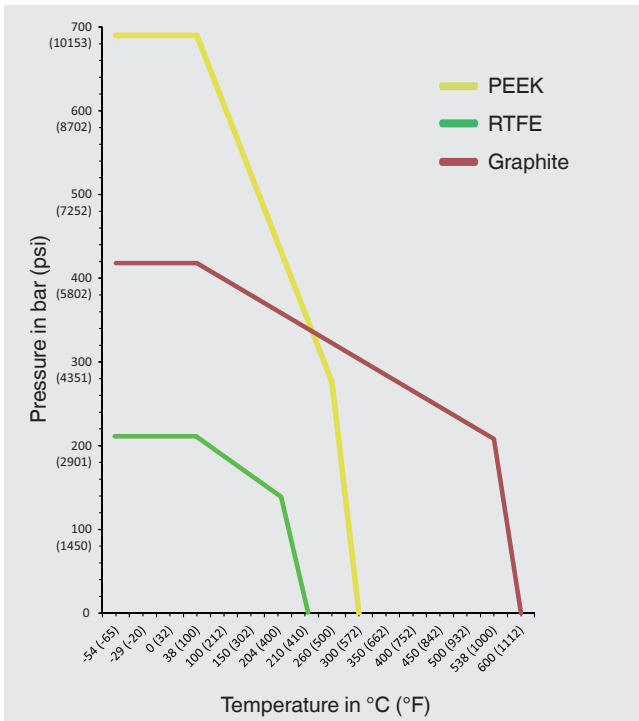

	Sealing material	Max. permissible operating pressure in bar at temperature in °C	Max. permissible operating pressure in psi at temperature in °F
<b>Ball valve seat</b>	PEEK <sup>1)</sup>	690 bar at 38 °C	10,000 psi at 100 °F
		276 bar at 260 °C	4,000 psi at 500 °F
	RTFE <sup>2)</sup>	210 bar at 38 °C	3,000 psi at 100 °F
		138 bar at 204 °C	2,000 psi at 400 °F
<b>Needle valve sealing packing</b>	Graphite	420 bar at 38 °C	6,000 psi at 100 °F
		209 bar at 538 °C	3,030 psi at 1,000 °F

1) Polyetheretherketone

2) Reinforced PTFE

The minimum design temperature is -55 °C [-67 °F]. For permanently low operating temperatures of  $\leq -55$  °C [ $\leq -67$  °F] a special design is required.

## Example designs of model IBF1

### Ball valve

Process connection: Flange

Instrument connection: 1/2 NPT female, axial

Vent connection:

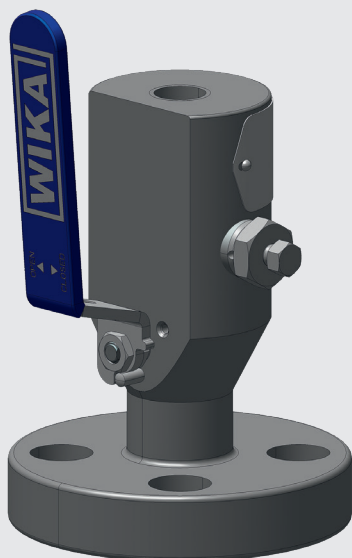

### Needle valve with OS&Y bonnet

Process connection: Flange

Instrument connection: 1/2 NPT female, axial

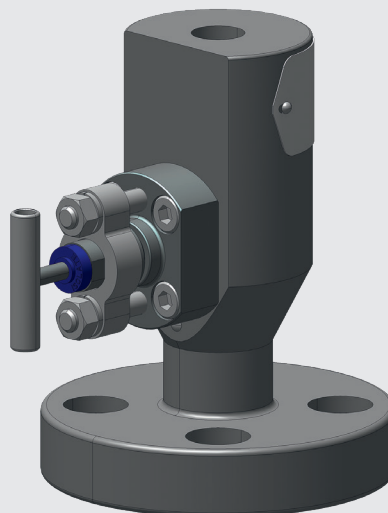

### Ball valve

Process and instrument connection: Flange

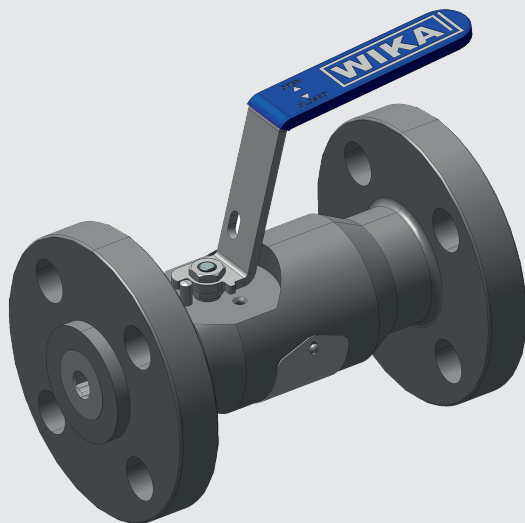

## Approvals

Logo	Description	Country
	<b>EAC (option)</b> Machinery directive	Eurasian Economic Community

## Manufacturer's information and certificates

Logo	Description
-	<b>PMI <sup>1)</sup> test certificate (option)</b> All wetted parts
-	<b>Type tested for fire safety in accordance with API 607, ISO 10497, BS 6755-2 2)</b>

1) Positive material identification  
2) Only for ball valve

## Certificates

- 3.1 inspection certificate per EN 10204 (option)
  - Material certificate for all wetted parts per NACE MR0103/MR0175
  - Confirmation of pressure tests per API 598 <sup>3)</sup>

3) Shell test: 15 s test duration with 1.5 times the permissible working air pressure  
Seat test: 15 s test duration with 6 bar air/nitrogen



© 07/2020 WIKA Alexander Wiegand SE & Co. KG, all rights reserved.  
The specifications given in this document represent the state of engineering at the time of publishing.  
We reserve the right to make modifications to the specifications and materials.  
In case of a different interpretation of the translated and the English data sheet, the English wording shall prevail.

