

# Threaded resistance thermometer With protection tube Model TR10-C

WIKA data sheet TE 60.03



For further approvals,  
see page 18

## Applications

- Machine building, plant and vessel construction
- Energy and power plant technology
- Chemical industry
- Food and beverage industry
- Sanitary, heating and air-conditioning technology

## Special features

- Sensor ranges from -196 ... +600 °C [-320 ... +1,112 °F]
- With integrated protection tube
- Spring-loaded measuring insert (replaceable)
- Explosion-protected versions are available for many approval types

## Description

Resistance thermometers of this series are intended to be screwed directly into the process, mainly in vessels and pipelines. They are suitable for liquid and gaseous media under moderate mechanical stress and normal chemical conditions.

The stainless steel thermowell is fully welded and screwed into the connection head. The interchangeable measuring insert can be removed without taking out the complete probe from the plant. This enables inspection, measuring equipment monitoring or, when servicing is necessary, replacement while the plant is running. (Exceptions are instruments with a perforated thermowell for temperature measurement in air ducts).



**Left: model TR10-C with protection tube**  
**Right: model TR10-C with perforated thermowell**

Configurator



Standard article



The choice of standard lengths assists with short delivery times and the possibility of stocking spare parts.

Insertion length, process connection, thermowell version, Connection head, sensor type and number, accuracy and connection method can be individually selected for the respective application. A large number of different explosion protection certificates are available for the TR10-C. On request, we can mount analogue or digital transmitters from the WIKA range in the connection head of the TR10-C.

# Specifications

## Representation of the components

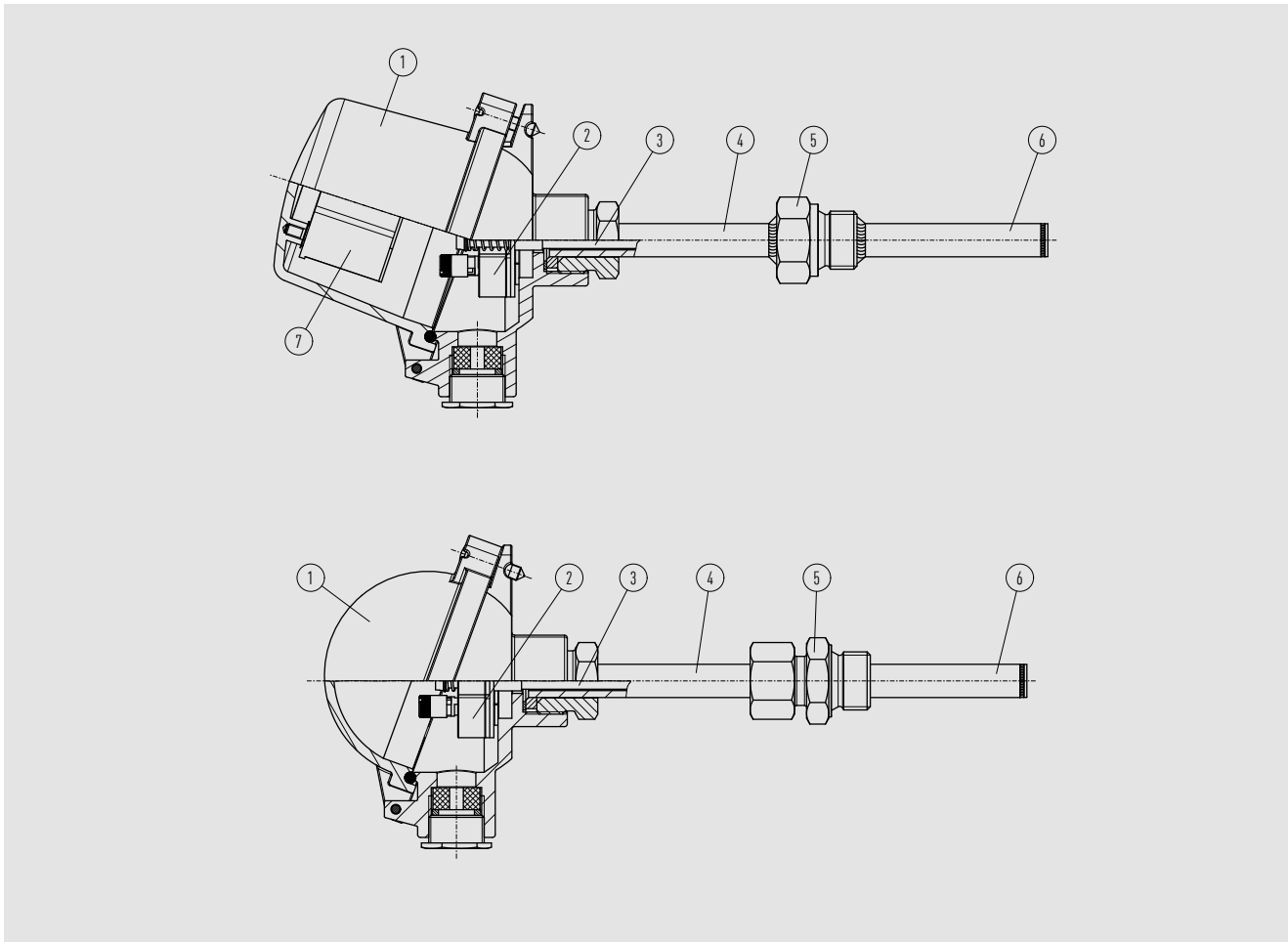

### Legend:

- ① Connection head
- ② Connection head / Transmitter (selectable)
- ③ Measuring insert (TR10-A)
- ④ Neck tube
- ⑤ Terminal block / Transmitter (selectable)
- ⑥ Protection tube
- ⑦ Transmitter (selectable)

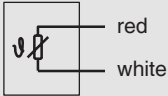
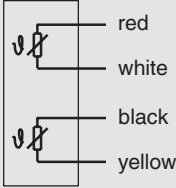
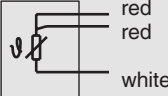
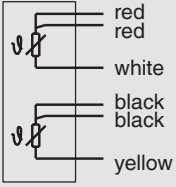
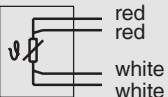
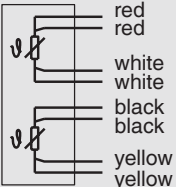
Measuring element			
Type of measuring element		Pt100, Pt1000	
Measuring current		0.1 ... 1.0 mA	
Connection method			
Single elements		Dual elements	
1 x 2-wire		2 x 2-wire	
1 x 3-wire		2 x 3-wire	
1 x 4-wire		2 x 4-wire <sup>1)</sup>	

#### Validity limits of the class accuracy in accordance with IEC 60751

Class B $\pm (0.30 + 0.0050   t  )$ <sup>3)</sup>	■ -196 ... +600 °C [-321 ... +1,112 °F]
	■ -196 ... +450 °C [-321 ... +842 °F]
Class A 2) $\pm (0.15 + 0.0020   t  )$ <sup>3)</sup>	■ -50 ... +500 °C [-58 ... +932 °F]
	■ -50 ... +250 °C [-58 ... +482 °F]
Class AA 2) $\pm (0.10 + 0.0017   t  )$ <sup>3)</sup>	-100 ... +450 °C [-148 ... +842 °F]
	-30 ... +300 °C [-22 ... +572 °F]
	-50 ... +250 °C [-58 ... +482 °F]
	0 ... 150 °C [32 ... 302 °F]

1) Not for 3 mm [0.118 in] diameter and 1/8 in [3.2 mm] diameter

2) Not for 2-wire connection method

3) | t | is the numerical value of the temperature in °C without consideration of the sign

→ For detailed specifications for Pt100 sensors, see technical information IN 00.17 at [www.wika.com](http://www.wika.com).

The table shows the temperature ranges listed in the respective standards, in which the tolerance values (class accuracies) are valid.

#### Measuring element with drift detection sensor technology

1 x 4-wire, class B, -50 ... +500 °C [-58 ... +932 °F]





1 x 4-wire, class B, -50 ... +200 °C [-58 ... +392 °F]

1 x 4-wire, class A, -30 ... +300 °C [-22 ... +572 °F]

- The combinations of a 2-wire connection with class A or class AA are not permissible, since the lead resistance of the MIMS cable and the connection lead negates the higher sensor accuracy.
- Longer probe/cable lengths should be designed with a 4-wire connection, since, with this connection method, the length has no effect on the accuracy.
- The use of TR10-C with a Pt100 sensor in a 2-wire connection is technically feasible, of course, but not recommended due to the lead resistance problem.

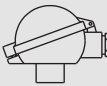
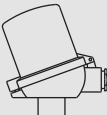
# Connection head

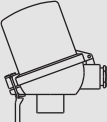
European designs per EN 50446 / DIN 43735

Model	Material	Thread size of cable inlet	Ingress protection (max.) <sup>1) 2)</sup> IEC/EN 60529	Cap	Surface	Connection to neck tube	
	<b>BSZ</b>	Aluminium	■ M20 x 1.5 ■ ½ NPT	IP65	Spherical hinged cover with cylinder head screw	Blue, painted (RAL 5022)	M24 x 1.5
	<b>BSZ-K</b>	Plastic	■ M20 x 1.5 ■ ½ NPT	IP65	Spherical hinged cover with cylinder head screw	Black	M24 x 1.5
	<b>BSZ-H</b>	Aluminium	■ M20 x 1.5 ■ ½ NPT	IP65	Raised hinged cover with cylinder head screw	Blue, painted (RAL 5022)	M24 x 1.5
	<b>BSZ-H (2 x cable outlet)</b>	Aluminium	■ 2 x M20 x 1.5 ■ 2 x ½ NPT	IP65	Raised hinged cover with cylinder head screw	Blue, painted (RAL 5022)	M24 x 1.5
	<b>BSZ-H / DIH10 <sup>3)</sup></b>	Aluminium	■ M20 x 1.5 ■ ½ NPT	IP65	Raised hinged cover with cylinder head screw	Blue, painted (RAL 5022)	M24 x 1.5
	<b>BSZ-H / TND <sup>4)</sup></b>	Aluminium	■ M20 x 1.5 ■ ½ NPT	IP65	Raised hinged cover with cylinder head screw	Blue, painted (RAL 5022)	M24 x 1.5
	<b>BSZ-HK</b>	Plastic	■ M20 x 1.5 ■ ½ NPT	IP65	Raised hinged cover with cylinder head screw	Black	M24 x 1.5
	<b>BS</b>	Aluminium	■ M20 x 1.5 ■ ½ NPT	IP65	Flat cover with 2 screws	Blue, painted (RAL 5022)	M24 x 1.5
	<b>BSS</b>	Aluminium	■ M20 x 1.5 ■ ½ NPT	IP65	Spherical hinged cover with clamping lever	Blue, painted (RAL 5022)	M24 x 1.5
	<b>BSS-H</b>	Aluminium	■ M20 x 1.5 ■ ½ NPT	IP65	Raised hinged cover with clamping lever	Blue, painted (RAL 5022)	M24 x 1.5
	<b>BVS</b>	Stainless steel	M20 x 1.5	IP65	Precision-cast screw-on lid	Natural finish, electropolished	M24 x 1.5

1) IP ingress protection of the connection head. The IP ingress protection of the complete TR10-C instrument does not necessarily have to correspond to the connection head.

2) Suitable sealing / cable gland required.

3) LED display DIH10 in combination with transmitter with 4 ... 20 mA output (loop)

4) LC display TND in combination with T38

→ Further thread sizes on request

Model	Explosion protection					
	Without	Ex i (gas) Zone 0, 1, 2	Ex i (dust) Zone 20, 21, 22	Ex e (gas) Zone 1, 2	Ex t (dust) Zone 21, 22	Ex nA (gas) Zone 2
<b>BSZ</b>	x	x	x	x <sup>1)</sup>	x <sup>1)</sup>	x <sup>2)</sup>
<b>BSZ-K</b>	x	x	-	-	-	-
<b>BSZ-H</b>	x	x	x	x <sup>1)</sup>	x <sup>1)</sup>	x <sup>2)</sup>
<b>BSZ-H (2 x cable outlet)</b>	x	x	x	x <sup>1)</sup>	x <sup>1)</sup>	x <sup>2)</sup>
<b>BSZ-H / DIH10 <sup>3)</sup></b>	x	x	-	-	-	-
<b>BSZ-H / TND <sup>4)</sup></b>	x	x	-	-	-	-
<b>BSZ-HK</b>	x	x	-	-	-	-
<b>BS</b>	x	x	x	-	-	-

Model	Explosion protection					
	Without	Ex i (gas) Zone 0, 1, 2	Ex i (dust) Zone 20, 21, 22	Ex e (gas) Zone 1, 2	Ex t (dust) Zone 21, 22	Ex nA (gas) Zone 2
BSS	x	x	-	-	-	-
BSS-H	x	x	-	-	-	-
BVS	x	x	-	-	-	-

- 1) Only ATEX
- 2) Only ATEX and EACEx
- 3) LED display DIH10 in combination with transmitter with 4 ... 20 mA output (loop)
- 4) LC display TND in combination with T38

### International designs

Model	Material	Thread size of cable inlet	Ingress protection (max.) <sup>1) 2)</sup> IEC/EN 60529	Cap	Surface	Connection to neck tube
 KN4-A	Aluminium	<ul style="list-style-type: none"> <li>■ ½ NPT</li> <li>■ M20 x 1.5</li> </ul>	IP65	Screw-on lid	Blue, painted (RAL 5022)	M24 x 1.5

Model	Explosion protection					
	Without	Ex i (gas) Zone 0, 1, 2	Ex i (dust) Zone 20, 21, 22	Ex e (gas) Zone 1, 2	Ex t (dust) Zone 21, 22	Ex nA (gas) Zone 2
KN4-A	x	x	-	-	-	-

### Connection head with digital display



**Connection head BSZ-H with model TND LC display**  
→ see data sheet TE 38.01



**Connection head BSZ-H with model DIH10 LED display**  
→ see data sheet AC 80.11

For operation of the TND digital display, a model T38 transmitter is always required.  
For operation of the DIH10 digital display, a transmitter with 4 ... 20 mA is always required.

## Cable inlet

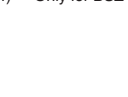
Cable inlet	Colour	Max. ingress protection <sup>1)</sup> DIN EN IEC 60529	Thread size of cable inlet	Min./Max. ambient temperature
 Standard cable inlet <sup>2)</sup>	Natural finish	IP65	M20 x 1.5	-40 ... +80 °C [-40 ... +176 °F]
 Plastic cable gland (cable Ø 6 ... 10 mm) <sup>2)</sup>	<ul style="list-style-type: none"> <li>■ Black</li> <li>■ Grey</li> </ul>	IP66	<ul style="list-style-type: none"> <li>■ M20 x 1.5</li> <li>■ ½ NPT</li> </ul>	-40 ... +80 °C [-40 ... +176 °F]
 Plastic cable gland (cable Ø 6 ... 10 mm), Ex e <sup>2)</sup>	<ul style="list-style-type: none"> <li>■ Light blue</li> <li>■ Black</li> </ul>	IP66	<ul style="list-style-type: none"> <li>■ M20 x 1.5</li> <li>■ ½ NPT</li> </ul>	<ul style="list-style-type: none"> <li>■ -20 ... +80 °C [-4 ... +176 °F]</li> <li>■ -40 ... +70 °C [-40 ... +158 °F]</li> </ul>
 Nickel-plated brass cable gland (cable Ø 6 ... 12 mm)	Natural finish	IP66	<ul style="list-style-type: none"> <li>■ M20 x 1.5</li> <li>■ ½ NPT</li> </ul>	-60 <sup>3)</sup> / -40 ... +80 °C [-76 / -40 ... +176 °F]
 Nickel-plated brass cable gland (cable Ø 6 ... 12 mm), Ex e	Natural finish	IP66	<ul style="list-style-type: none"> <li>■ M20 x 1.5</li> <li>■ ½ NPT</li> </ul>	-60 <sup>3)</sup> / -40 ... +80 °C [-76 / -40 ... +176 °F]
 Stainless steel cable gland (cable Ø 7 ... 12 mm)	Natural finish	IP66	<ul style="list-style-type: none"> <li>■ M20 x 1.5</li> <li>■ ½ NPT</li> </ul>	-60 <sup>3)</sup> / -40 ... +80 °C [-76 / -40 ... +176 °F]
 Stainless steel cable gland (cable Ø 7 ... 12 mm), Ex e	Natural finish	IP66	<ul style="list-style-type: none"> <li>■ M20 x 1.5</li> <li>■ ½ NPT</li> </ul>	-60 <sup>3)</sup> / -40 ... +80 °C [-76 / -40 ... +176 °F]
 Plain threaded	-	IP00	<ul style="list-style-type: none"> <li>■ M20 x 1.5</li> <li>■ ½ NPT</li> </ul>	-
 2 x plain threaded <sup>4)</sup>	-	IP00	<ul style="list-style-type: none"> <li>■ 2 x M20 x 1.5</li> <li>■ 2 x ½ NPT</li> </ul>	-
 Built-in connector (male) M12 x 1 (4-pin) Built-in connector (female) M12 x 1 (4-pin)	-	IP65	M20 x 1.5	-40 ... +80 °C [-40 ... +176 °F]
 Sealing plugs for shipping	Transparent	-	<ul style="list-style-type: none"> <li>■ M20 x 1.5</li> <li>■ ½ NPT</li> </ul>	-40 ... +80 °C [-40 ... +176 °F]

1) IP ingress protection of the cable gland. The IP ingress protection of the complete TR10-C instrument does not necessarily have to correspond to the cable gland.

2) Not available for BVS connection head

3) Special version on request (explosion-protected versions only available with specific approvals)

4) Only for BSZ-H connection head

Cable inlet	Explosion protection					
	With-out	Ex i (gas) Zone 0, 1, 2	Ex i (dust) Zone 20, 21, 22	Ex e (gas) Zone 1, 2	Ex t (dust) Zone 21, 22	Ex nA (gas) Zone 2
Standard cable inlet <sup>1) 3)</sup>	x	x	-	-	-	-
Plastic cable gland <sup>1)</sup>	x	x	-	-	-	-
Plastic cable gland (light blue), Ex e <sup>1)</sup>	x	x	x	-	-	-
Plastic cable gland (black), Ex e <sup>1)</sup>	x	x	x	x	x	x
Brass cable gland, nickel-plated	x	x	x	-	-	-
Brass cable gland, nickel-plated, Ex e	x	x	x	x	x	x
Stainless steel cable gland	x	x	x	-	-	-
Stainless steel cable gland, Ex e	x	x	x	x	x	x
Plain threaded	x	x	x <sup>5)</sup>	x <sup>5)</sup>	x <sup>5)</sup>	x <sup>5)</sup>
2 x plain threaded <sup>2)</sup>	x	x	x <sup>5)</sup>	x <sup>5)</sup>	x <sup>5)</sup>	x <sup>5)</sup>
Junction box M12 x 1 (4-pin) <sup>3)</sup>	x	x <sup>4)</sup>	x <sup>4)</sup>	-	-	-
Sealing plugs for shipping	Not applicable, transport protection <sup>5)</sup>					

1) Not available for BVS connection head

2) Only for BSZ-H connection head



3) Not available for ½ NPT thread size of cable entry

4) With appropriate mating connector connected

5) Suitable cable gland required for operation

Measuring insert		
Version	Vibration-resistant mineral-insulated metal-sheathed cable (MIMS cable)	
Optimal heat transfer	Requirement <ul style="list-style-type: none"> <li>■ Correct measuring insert length</li> <li>■ Correct measuring insert diameter</li> </ul>	
	Bore diameter of the thermowell	Max. 1 mm [0.039 in] larger than the measuring insert diameter
	Gap width	With gap widths > 0.5 mm [> 0.020 in] between thermowell and measuring insert: → Negative impact on heat transfer → Unfavourable response behaviour of the thermometer
Insertion length	When fitting the measuring insert into a thermowell, it is very important to determine the correct insertion length (= thermowell length for tip thicknesses of ≤ 5.5 mm [≤ 0.217 in]). In order to ensure that the measuring insert is firmly pressed down onto the bottom of the thermowell, the insert must be spring-loaded (spring travel: max. 10 mm [0.394 in]).	
Spring travel	Max. 10 mm [0.394 in]	

Measuring insert diameter Ø d in mm [in]		Code number per DIN 43735	Tolerance in mm	Sheath material
3 [0.118]	Standard	30	3 <sup>+0.05</sup> <sub>-0.05</sub>	1.4571 316L
6 [0.236]	Standard	60	6 <sup>0</sup> <sub>-0.1</sub>	
8 [0.315]	Standard	80	8 <sup>0</sup> <sub>-0.1</sub>	1.4571 316L
8 [0.315] (6 [0.236] with sleeve)	Standard	-	8 <sup>0</sup> <sub>-0.1</sub>	1.4571

Transmitter models	Model T15	Model T38
Transmitter data sheet	TE 15.01	TE 38.01
Figure		
<b>Output signal</b>		
4 ... 20 mA	x	x
HART® protocol	-	x
WIKA True Drift Detection	-	x
		→ See data sheet SP 05.26
<b>Connection method</b>	<ul style="list-style-type: none"> <li>■ 1 x 2-wire</li> <li>■ 1 x 3-wire</li> <li>■ 1 x 4-wire</li> </ul>	<ul style="list-style-type: none"> <li>■ 1 x 2-wire</li> <li>■ 1 x 3-wire</li> <li>■ 1 x 4-wire</li> <li>■ 2 x 2-wire</li> <li>■ 2 x 3-wire</li> </ul>
<b>Measuring current</b>	< 0.2 mA	< 0.33 mA
<b>Explosion protection</b>	Ex version possible	
<b>Mounting types</b>		
Mounting onto the measuring insert	With mounting on the measuring insert, the transmitter replaces the terminal block and is fixed directly to the terminal plate of the measuring insert.	
Mounted within the cover of the connection head	Mounting the transmitter in the cover of the connection head is preferable to mounting it on the measuring insert. With this mounting type, for one, a better thermal insulation is ensured, and in addition, exchange and mounting for servicing is simplified.	



## Mounting types

When using dual sensors in combination with a single transmitter, sensor 1 is connected to the transmitter. The connection leads of sensor 2 (insulated against short-circuits) protrude loosely into the connection head.

Exceptions:

T38: The combination of a 2 x 2-wire or 2 x 3-wire in combination with a T38 transmitter in the "redundancy" configuration.

Mounting onto the measuring insert



Measuring insert with mounted transmitter

Measuring insert prepared for transmitter mounting

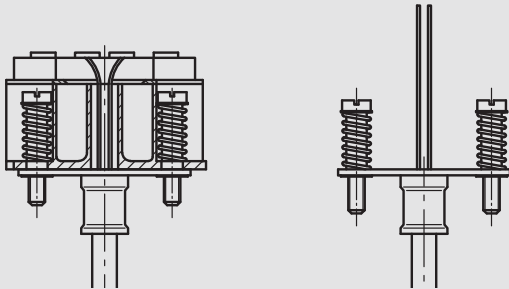

Mounted within the cover of the connection head

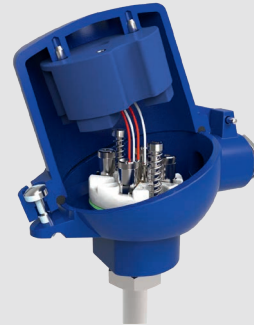

## WIKA True Drift Detection



### Special dual sensor functionality

- Special probe (RTD/TC combination, realised in the common probe tip of a measuring insert with 6 mm diameter, in combination with T38 transmitter)
- Permanent monitoring of the resistance sensor by the reference thermocouple
- An incorrect reading can be detected immediately and before the next recalibration. Uncertainties between the calibration intervals are thus eliminated
- Error signalling in accordance with NAMUR NE043, can be configured in accordance with customer specifications
- Individual monitoring of the single measuring locations
- Process optimisation

Possible transmitter mounting positions	Model T15	Model T38
BSZ	○	○
BSZ-K	○	○
BSZ-H	●	●
BSZ-H (2x cable outlet)	●	●
BSZ-H / DIH10	○	○
BSZ-H / TND	○	○
BSZ-HK	●	●
BS	○	-
BSS	○	○
BSS-H	●	●
BVS	○	○
KN4-A	○	○

Legend:

- Mounted instead of terminal block
- Mounted within the cover of the connection head
- Mounting not possible

The mounting of a transmitter on the measuring insert is possible with all the connection heads listed here. The fitting of a transmitter in the (screw) cap of a connection head is not possible. Mounting of 2 transmitters on request.

For a correct determination of the overall measuring deviation, the sensor and transmitter measuring deviations must be added.

#### Functional safety with model T38 temperature transmitter



In safety-critical applications, the entire measuring chain must be taken into consideration in terms of the safety parameters. The SIL classification allows the assessment of the risk reduction achieved by the safety installations.

Selected TR10-C resistance thermometers, in combination with a suitable temperature transmitter (e.g. model T38, TÜV certified SIL version for protection systems developed in accordance with IEC 61508), are suitable as sensors for safety functions to SIL 2.

For SIL 3 applications, WIKA recommends the use of two individual TR10-C with one SIL-certified T38 transmitter connected to each.

→ For details, see technical information IN 00.19 on [www.wika.com](http://www.wika.com).

## Thermowell versions

The thermowells are made of drawn tube with a welded base in the versions in accordance with DIN 43772 and are screwed into the connection head with a swivel connection (male nut). By loosening this male nut, the connection head, and thus the cable outlet, can be adjusted to the desired position.

In the version “with perforated thermowell”, a seal prevents the medium (air) from entering the connection head (max. 1 bar [15 psi]).

The process connection is either welded on at the factory in accordance with customer specifications - which means that the insertion length is fixed - or offers a variable insertion length by using a compression fitting.

Versions without process connection are also available.

Thermowell versions with double threaded hex bushing are screwed directly into the connection head. The connection head cannot be rotated with this design.

The immersion depth into the process medium should be at least 10 times the thermowell outer diameter. This minimises heat dissipation effects that could have a negative impact on the measuring result.

Thermowell in accordance with DIN 43772	Thermowell diameter	Process connection	Suitable for measuring insert diameter	Connection to head	Material <sup>1)</sup>			
<b>Straight, form 2G, mounting thread</b>	9 x 1 mm [0.35 ... 0.04 in]	G ¼ B, mounting thread	6 mm [0.24 in]	M24 x 1.5 (swivel connection, male nut)	1.4571			
		G ½ B, mounting thread						
		G ¾ B, mounting thread						
		G 1 B, mounting thread						
		M18 x 1.5, mounting thread						
		M20 x 1.5, mounting thread						
		M27 x 2, mounting thread						
		½ NPT, mounting thread						
		¾ NPT, mounting thread						
	11 x 2 mm [0.43 ... 0.08 in] 12 x 2,5 mm [0.47 ... 0.09 in]	G ½ B, mounting thread	6 mm [0.24 in]					
		G ¾ B, mounting thread						
		G 1 B, mounting thread						
		M18 x 1.5, mounting thread						
		M20 x 1.5, mounting thread						
		M27 x 2, mounting thread						
		½ NPT, mounting thread						
		¾ NPT, mounting thread						
		14 x 2,5 mm [0.55 ... 0.09 in]				G ½ B, mounting thread	8 mm [0.32 in] (6 mm [0.24 in] with sleeve)	
	G ¾ B, mounting thread							
	G 1 B, mounting thread							
	M18 x 1.5, mounting thread							
	M20 x 1.5, mounting thread							
	M27 x 2, mounting thread							
	½ NPT, mounting thread							
	¾ NPT, mounting thread							
	<b>Tapered, form 3G, mounting thread</b>		12 x 2,5 mm [0.47 ... 0.09 in], verjüngt auf 9 mm [0.35 in]			G ½ B, mounting thread		6 mm [0.24 in]
		G ¾ B, mounting thread						
G 1 B, mounting thread								
M18 x 1.5, mounting thread								
M20 x 1.5, mounting thread								
M27 x 2, mounting thread								
½ NPT, mounting thread								
¾ NPT, mounting thread								

Thermowell in accordance with DIN 43772	Thermowell diameter	Process connection	Suitable for measuring insert diameter	Connection to head	Material <sup>1)</sup>
<b>Straight, plain, form 2, with/without compression fitting</b>	9 x 1 mm [0.35 ... 0.04 in]	G ½ B compression fitting (metal ferrule)	6 mm [0.24 in]	M24 x 1.5 (swivel connection, male nut)	1.4571
	11 x 2 mm [0.43 ... 0.08 in]	½ NPT compression fitting (metal ferrule)			
	12 x 2.5 mm [0.47 ... 0.09 in]	Without threaded connection, plain			
<b>Tapered, plain, form 3, with/without compression fitting</b>	12 x 2.5 mm [0.47 ... 0.09 in], verjüngt auf 9 mm [0.35 in]	G ½ B compression fitting (metal ferrule)	6 mm [0.24 in]	M24 x 1.5 (swivel connection, male nut)	1.4571
		½ NPT compression fitting (metal ferrule)			
		Without threaded connection, plain			

1) Other materials on request.

Tapered thermowell, not standardised	Thermowell diameter	Process connection	Suitable for measuring insert diameter	Connection to head	Material <sup>1)</sup>		
<b>Tapered, weld-on solid tip, mounting thread</b>	9 x 1 mm, [0.35 ... 0.04 in], tapered to 6 mm 6 mm [0.24 in]	G ¼ B, mounting thread	3 mm [0.12 in]	M24 x 1.5 (swivel connection, male nut)	1.4571		
		G ½ B, mounting thread					
		G ¾ B, mounting thread					
		G 1 B, mounting thread					
		M18 x 1.5, mounting thread					
		M20 x 1.5, mounting thread					
		M27 x 2, mounting thread					
		½ NPT, mounting thread					
		¾ NPT, mounting thread					
		11 x 2 mm [0.43 ... 0.08 in], tapered to 6 mm [0.24 in]				G ½ B, mounting thread	
						G ¾ B, mounting thread	
						G 1 B, mounting thread	
						12 x 2.5 mm [0.47 ... 0.09 in], tapered to 6 mm [0.24 in]	M14 x 1.5, mounting thread
							M18 x 1.5, mounting thread
M20 x 1.5, mounting thread							
½ NPT, mounting thread							
¾ NPT, mounting thread							
<b>Tapered, weld-on solid tip, plain, with/without compression fitting</b>	9 x 1 mm [0.35 ... 0.04 in], tapered to 6 mm [0.24 in]	G ½ B compression fitting (metal ferrule)	6 mm [0.24 in]	M24 x 1.5 (swivel connection, male nut)	1.4571		
		11 x 2 mm [0.43 ... 0.08 in], tapered to 6 mm [0.24 in]				½ NPT compression fitting (metal ferrule)	
		12 x 2.5 mm [0.47 ... 0.09 in], tapered to 6 mm [0.24 in]				Without threaded connection, plain	

1) Other materials on request.

Straight thermowell, not standardised	Thermowell diameter	Process connection	Suitable for measuring insert diameter	Connection to head	Material
<b>Straight, mounting thread</b>	6 x 1 mm [0.24 ... 0.04 in] 8 x 1 mm [0.32 ... 0.04 in]	G 1/4 B, mounting thread	3 mm [0.12 in]	M24 x 1.5 (swivel connection, male nut)	1.4571 316L (8 x 1 mm [0.32 ... 0.04 in])
		G 1/2 B, mounting thread			
		M18 x 1.5, mounting thread			
		M20 x 1.5, mounting thread			
		1/2 NPT, mounting thread			
	8 x 0,9 mm [0.32 ... 0.04 in] Fühlerspitze perforiert	G 1/2 B, mounting thread	6 mm [0.24 in]	M24 x 1.5 (swivel connection, male nut)	1.4571
		G 1/2 B compression fitting (metal ferrule)			
	10 x 1 mm [0.39 ... 0.04 in] 10 x 1.5 mm [0.39 ... 0.06 in]	G 1/2 B, mounting thread	6 mm [0.24 in]	M24 x 1.5 (swivel connection, male nut)	316L
		G 3/4 B, mounting thread			
		G 1 B, mounting thread			
		M18 x 1.5, mounting thread			
		M20 x 1.5, mounting thread			
		M27 x 2, mounting thread			
		1/2 NPT, mounting thread			
		3/4 NPT, mounting thread			
	12 x 1 mm [0.47 ... 0.04 in] 12 x 1.5 mm [0.47 ... 0.06 in]	G 1/2 B, mounting thread	8 mm [0.32 in] (6 mm [0.24 in] with sleeve)	M24 x 1.5 (swivel connection, male nut)	316L
G 3/4 B, mounting thread					
G 1 B, mounting thread					
M18 x 1.5, mounting thread					
M20 x 1.5, mounting thread					
M27 x 2, mounting thread					
1/2 NPT, mounting thread					
3/4 NPT, mounting thread					
<b>Straight, hexagonal threaded connection, double threaded hex bushing</b>	9 x 1 mm [0.35 ... 0.04 in] 12 x 2.5 mm [0.47 ... 0.09 in] 10 x 1.5 mm [0.39 ... 0.06 in]	G 1/4 B, mounting thread	6 mm [0.24 in]	M24 x 1.5 (not rotatable, fixed threaded connection)	1.4571 316 L
		G 1/2 B, mounting thread			
		G 3/4 B, mounting thread			
		M18 x 1.5, mounting thread			
		1/2 NPT, mounting thread			
	6 x 1 mm [0.24 ... 0.04 in]	G 1/4 B, mounting thread	3 mm [0.12 in]		
		G 1/2 B, mounting thread			
		G 3/4 B, mounting thread			
		M18 x 1.5, mounting thread			
		1/2 NPT, mounting thread			
	8 x 0.9 mm [0.32 ... 0.04 in] Perforated probe tip	G 1/2 B, mounting thread	6 mm [0.24 in]	M24 x 1.5 (not rotatable, fixed threaded connection)	1.4571
		G 1/2 B compression fitting (metal ferrule)			
<b>Straight, plain, with/without compression fitting</b>	6 x 1 mm [0.24 ... 0.04 in] 8 x 1 mm [0.32 ... 0.04 in]	G 1/2 B compression fitting (metal ferrule)	3 mm [0.12 in]	M24 x 1.5 (swivel connection, male nut)	1.4571 316L (8 x 1 mm [0.32 ... 0.04 in])
		1/2 NPT compression fitting (metal ferrule)			
		Without threaded connection, plain			
	9 x 1 mm [0.35 ... 0.04 in] 10 x 1 mm [0.39 ... 0.04 in] 10 x 1,5 mm [0.39 ... 0.06 in] 12 x 1 mm [0.47 ... 0.04 in] 12 x 1.5 mm [0.47 ... 0.06 in]	G 1/2 B compression fitting (metal ferrule)	6 mm [0.24 in]		1.4571 (9 x 1 mm [0.35 ... 0.04 in]) 316L
		1/2 NPT compression fitting (metal ferrule)			
		Without threaded connection, plain			

Thermowell design	Standard insertion length	Min./Max. insertion length
Straight, mounting thread, form 2G DIN 43772	100, 160, 250, 400 mm [3,94, 6,23, 9,84, 15,75 in]	50 mm / 4.000 mm [1,97 in / 157,48 in]
Straight, hexagonal threaded connection (double threaded hex bushing)	100, 160, 250, 400 mm [3,94, 6,23, 9,84, 15,75 in]	50 mm / 4.000 mm [1,97 in / 157,48 in]
Tapered, mounting thread, form 3G DIN 43772	160, 220, 280 mm [6,23, 8,66, 11,02 in]	110 mm / 4.000 mm [4,33 in / 157,48 in]
Straight, plain, with/without compression fitting, form 2 DIN 43772	-	50 mm / 4.000 mm [1,97 in / 157,48 in]
Tapered, plain, with/without compression fitting, form 3 DIN 43772	-	110 mm / 4.000 mm [4,33 in / 157,48 in]
Tapered, weld-on solid tip, mounting thread, not standardised design	100, 160, 250, 400 mm [3,94, 6,23, 9,84, 15,75 in]	75 mm / 4.000 mm [2,95 in / 157,48 in]
Tapered, plain, weld-on solid tip, with/without compression fitting, not standardised design	-	75 mm / 4.000 mm [2,95 in / 157,48 in]
Straight, mounting thread, thermowell perforated at the probe tip	100, 160, 250, 400 mm [3,94, 6,23, 9,84, 15,75 in]	100 mm / 400 mm [3,94 in / 15,75 in]
Compression fitting, thermowell perforated at the probe tip	-	100 mm / 400 mm [3,94 in / 15,75 in]

### Neck lengths

Thermowell design	Standard neck length	Min./Max. neck length
Straight, mounting thread, form 2G DIN 43772	130 mm [5,12 in]	30 mm / 1.000 mm [1,18 in / 39,37 in]
Tapered, mounting thread, form 3G DIN 43772	132 mm [5,19 in]	30 mm / 1.000 mm [1,18 in / 39,37 in]
Straight, plain, with compression fitting, form 2 DIN 43772	50 mm [1,97 in]	50 mm [1,97 in]
Straight, plain, without compression fitting, form 2 DIN 43772	-	-
Tapered, plain, with compression fitting, form 3 DIN 43772	50 mm [1,97 in]	50 mm [1,97 in]
Tapered, plain, without compression fitting, form 3 DIN 43772	-	-
Tapered, weld-on solid tip, mounting thread, not standardised design	130 mm [5,12 in]	30 mm / 1.000 mm [1,18 in / 39,37 in]
Tapered, weld-on solid tip, with compression fitting, not standardised design	50 mm [1,97 in]	50 mm [1,97 in]
Tapered, weld-on solid tip, without process connection, not standardised design	-	-
Straight, hexagonal threaded connection, double threaded hex bushing	13 mm [0,51 in]	-

The neck is screwed into the connection head. The neck length depends on the intended use.

Usually, an isolation is bridged by the neck tube. Also, in many cases, the neck tube serves as a cooling element between the connection head and the medium, in order to protect a possible built-in transmitter from high medium temperatures.

→ Other versions on request

Operating conditions	
Ambient and storage temperature	<ul style="list-style-type: none"> <li>■ -40 ... +80 °C [-40 ... +176 °F]</li> <li>■ -60 <sup>1)</sup> ... +80 °C [-76 ... +176 °F]</li> </ul>
Vibration resistance	The information on vibration resistance refers to the tip of the measuring insert.

1) Special version on request (explosion-protected versions only available with specific approvals)

Examples of vibration resistance		
	Measuring insert Ø 6 mm [0.236 in]	Measuring insert Ø 3 mm [0.118 in]
<b>Thermometer version</b>		
Sensor	<ul style="list-style-type: none"> <li>■ 1 x Pt100 (thin film)</li> <li>■ 2 x Pt100 (thin film)</li> </ul>	<ul style="list-style-type: none"> <li>■ 1 x Pt100 (thin film)</li> <li>■ 2 x Pt100 (thin film)</li> </ul>
Connection method	<ul style="list-style-type: none"> <li>■ 3-wire</li> <li>■ 4-wire</li> </ul>	<ul style="list-style-type: none"> <li>■ 3-wire</li> <li>■ 4-wire (only 1 x Pt100)</li> </ul>
Diameter	6 mm [0.236 in]	3 mm [0.118 in]
Insertion length (A) + neck length (N)	100 ... 1,100 mm [~ 4 ... 43 in]	100 ... 1,100 mm [~ 4 ... 43 in]
Material	<ul style="list-style-type: none"> <li>■ Stainless steel 1.4571</li> <li>■ Stainless steel 316L</li> </ul>	<ul style="list-style-type: none"> <li>■ Stainless steel 1.4571</li> <li>■ Stainless steel 316L</li> </ul>
<b>Vibration resistance</b>		
Standard probe tip, (max. 3 g amplitude / 6 g peak-to-peak)	x	x
Vibration-resistant probe tip (max. 10 g amplitude / 20 g peak-to-peak)	x	x
Highly vibration-resistant probe tip (max. 25 g amplitude / 50 g peak-to-peak)	x	x
Extremely vibration-resistant probe tip (max. 50 g amplitude / 100 g peak-to-peak)	x	-

The thermometer designs listed above describe instruments in standard designs.

Testing of the vibration resistance per IEC 60068-2-6. Vibration resistance of thermometers in other configurations as well as vibration resistance higher than 50 g amplitude / 100 g tip - tip on request.

#### Max. process temperature, process pressure, dependent on:

- Load diagram DIN 43772
- Thermowell version (dimensions, material)
- Process conditions (flow rate, medium density)

#### Wake frequency calculation

With critical operating conditions, a wake frequency calculation in accordance with Dittrich/Klotter is recommended as a WIKA engineering service. Note: ASME PTC 19.3 TW-2016 is not applicable for the TR10-C.

→ For further information, see technical information IN 00.15

## IP ingress protection per DIN IEC/EN 60529

First numeral	Degree of protection / Short description	Test parameters
<b>Degrees of protection against solid foreign bodies (defined by the 1st numeral)</b>		
5	Dust-protected	Per DIN EN IEC 60529
6	Dust-tight	Per DIN EN IEC 60529
<b>Degrees of protection against water (defined by the 2nd numeral)</b>		
4	Protected against splash water	Per DIN EN IEC 60529
5	Protected against water jets	Per DIN EN IEC 60529
6	Protected against strong water jets	Per DIN EN IEC 60529

→ For further information, see technical information IN 00.64 at [www.wika.com](http://www.wika.com).

Standard ingress protection of model TR10-C is IP65.

The specified degrees of protection apply under the following conditions:

- Use of a suitable cable gland
- Use of a cable cross-section appropriate for the gland or select the appropriate cable gland for the available cable
- Adhere to the tightening torques for all threaded connections

## Instruments with a connection head

### Dichtung at the connection head

A ring-shaped seal in the cover of the connection head and a suitable cable gland prevent the ingress of dust and water.

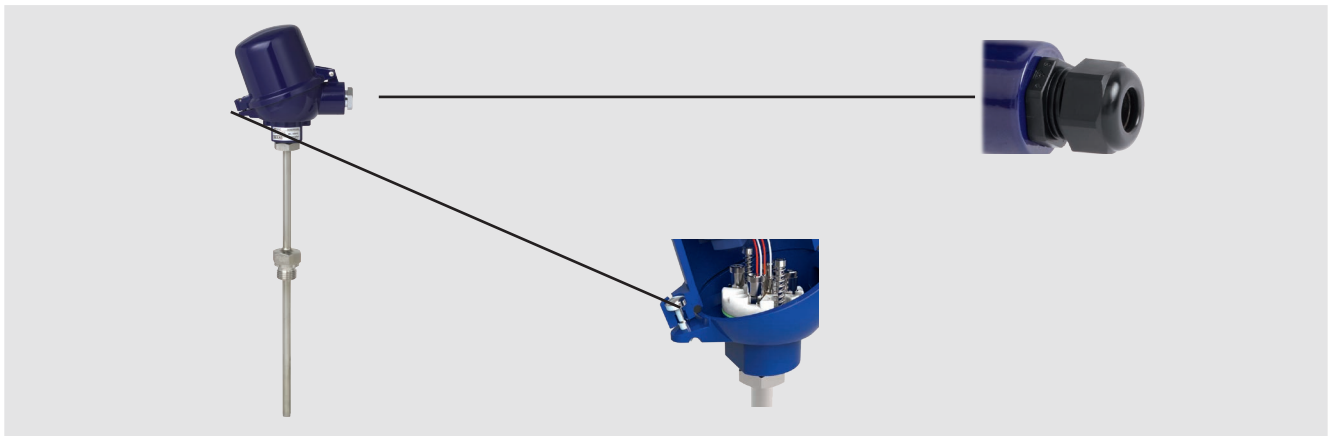

### Abdichtung at the connection point of the thermowell/protection tube / neck tube to the connection head

The thermowell/protection tube is screwed to the connection head or neck tube, which means that IP65 ingress protection is usually achieved without any problems. A suitable ring-shaped seal and, if necessary, PTFE sealing tape are used.





Examples of response time for measuring insert		
	Measuring insert Ø 6 mm [0.236 in]	Measuring insert Ø 3 mm [0.118 in]
<b>Thermometer version</b>		
Sensor	<ul style="list-style-type: none"> <li>■ 1 x Pt100 (thin film)</li> <li>■ 2 x Pt100 (thin film)</li> </ul>	<ul style="list-style-type: none"> <li>■ 1 x Pt100 (thin film)</li> <li>■ 2 x Pt100 (thin film)</li> </ul>
Connection method	<ul style="list-style-type: none"> <li>■ 3-wire</li> <li>■ 4-wire</li> </ul>	<ul style="list-style-type: none"> <li>■ 3-wire</li> <li>■ 4-wire (only 1 x Pt100)</li> </ul>
Diameter	6 mm [0.236 in]	3 mm [0.118 in]
Insertion length (A) + neck length (N)	100 ... 1,100 mm [~ 4 ... 43 in]	100 ... 1,100 mm [~ 4 ... 43 in]
Material	<ul style="list-style-type: none"> <li>■ Stainless steel 1.4571</li> <li>■ Stainless steel 316L</li> </ul>	<ul style="list-style-type: none"> <li>■ Stainless steel 1.4571</li> <li>■ Stainless steel 316L</li> </ul>
<b>Response time in seconds (+/- 10 %)</b>		
$t_{0.5}$	3.8	2.8
$t_{0.63}$	4.8	3.5
$t_{0.9}$	8.6	6.6

Example for the response time of the complete instrument			
	Straight, form 2G, mounting thread	Tapered, form 3G, mounting thread	Tapered, weld-on solid tip, mounting thread
<b>Thermometer version</b>			
Sensor	<ul style="list-style-type: none"> <li>■ 1 x Pt100 (thin film)</li> <li>■ 2 x Pt100 (thin film)</li> </ul>	<ul style="list-style-type: none"> <li>■ 1 x Pt100 (thin film)</li> <li>■ 2 x Pt100 (thin film)</li> </ul>	<ul style="list-style-type: none"> <li>■ 1 x Pt100 (thin film)</li> <li>■ 2 x Pt100 (thin film)</li> </ul>
Connection method	<ul style="list-style-type: none"> <li>■ 3-wire</li> <li>■ 4-wire</li> </ul>	<ul style="list-style-type: none"> <li>■ 3-wire</li> <li>■ 4-wire (only 1 x Pt100)</li> </ul>	<ul style="list-style-type: none"> <li>■ 3-wire</li> <li>■ 4-wire (only 1 x Pt100)</li> </ul>
Thermowell	2G (DIN 43772)	3G (DIN 43772)	Weld-on solid tip
Diameter	9 mm [0.354 in]	12 mm to 9 mm [0.472 in to 0.354 in]	9 mm to 6 mm [0.354 in to 0.236 in]
Insertion length (A) + neck length (N)	100 ... 1,000 mm [~ 4 ... 40 in]	100 ... 1,000 mm [~ 4 ... 40 in]	100 ... 1,000 mm [~ 4 ... 40 in]
Material	<ul style="list-style-type: none"> <li>■ Stainless steel 1.4571</li> <li>■ Stainless steel 316L</li> </ul>	<ul style="list-style-type: none"> <li>■ Stainless steel 1.4571</li> <li>■ Stainless steel 316L</li> </ul>	<ul style="list-style-type: none"> <li>■ Stainless steel 1.4571</li> <li>■ Stainless steel 316L</li> </ul>
<b>Response time in seconds (+/- 10 %)</b>			
$t_{0.5}$	21	11	12
$t_{0.63}$	27	14	15
$t_{0.9}$	65	25	33

Fundamentals of measurements:

VDI/VDE directive 3522 part 1: Dynamic behaviour of contact thermometers / Principles and characteristic values

VDI/VDE directive 3522 part 2 Dynamic behaviour of contact thermometers / Experimental determination of time percentage values

IEC 60751 Definition of thermal response time / Specification of measurement parameters

IEC 60751 Thermal response time





Medium: water







→ Further response times of thermometers in other dimensions, configurations or materials on request.

## Approvals

Logo	Description	Region
	<b>EU declaration of conformity</b>	European Union
	EMC directive <sup>1)</sup>	
	EN 61326 emission (group 1, class B) and immunity (industrial environments)	
	RoHS directive	

## Optional approvals

Logo	Description	Region
	<b>EU declaration of conformity</b>	European Union
	<p>ATEX directive</p> <p>Hazardous areas</p> <p>- Ex i Zone 0 gas II 1G Ex ia IIC T6...T1 Ga</p> <p>Zone 1 gas II 2G Ex ia IIC T6...T1 Gb</p> <p>Zone 1 mounting to zone 0 gas II 1/2G Ex ia IIC T6...Ta Ga/Gb</p> <p>Zone 20 dust II 1D Ex ia IIIC T<sub>200</sub>X °C Da</p> <p>Zone 21 dust II 2D Ex ia IIIC TX °C Db</p> <p>Zone 21 mounting to zone 20 dust II 1/2D Ex ia IIIC TX °C Da/Db</p> <p>- Ex n Zone 1 gas II 2G Ex eb IIC T6...T1 Gb <sup>2) 3)</sup></p> <p>Zone 2 gas II 3G Ex ec IIC T6...T1 Gc X</p> <p>Zone 21 dust II 2D Ex tb IIIC Tx °C Db <sup>2) 3)</sup></p> <p>Zone 22 dust II 3D Ex tc IIIC TX °C Dc X</p> <p>- Ex t Zone 21 dust II 2D Ex tb IIIC TX °C Db <sup>2) 3)</sup></p> <p>Zone 22 dust II 3D Ex tc IIIC TX °C Dc X</p>	
	<b>IECEx</b>	International
	<p>Hazardous areas</p> <p>- Ex i Zone 0 gas Ex ia IIC T6...T1 Ga</p> <p>Zone 1 gas Ex ia IIC T6...T1 Gb</p> <p>Zone 1 mounting to zone 0 gas Ex ia IIC T6...T1 Ga/Gb</p> <p>Zone 20 dust Ex ia IIIC T<sub>200</sub>X °C Da</p> <p>Zone 21 dust Ex ia IIIC TX °C Db</p> <p>Zone 21 mounting to zone 20 dust Ex ia IIIC TX °C Da/Db</p>	
	<b>EAC</b>	Eurasian Economic Community
	<p>Hazardous areas</p> <p>- Ex i Zone 0 gas 0 Ex ia IIC T6...T1 Ga X</p> <p>Zone 1 gas 1 Ex ia IIC T6...T1 Gb X</p> <p>Zone 20 dust Ex ia IIIC T65...T125 °C Da X</p> <p>Zone 21 dust Ex ib IIIC T65...T125 °C Db X</p> <p>- Ex n Zone 1 gas 1Ex eb IIC T6...T1 Gb X <sup>2)</sup></p> <p>Zone 2 gas 2Ex ec IIC T6...T1 Gc X</p>	
	<b>Ex Ukraine</b>	Ukraine
	<p>Hazardous areas</p> <p>- Ex i Zone 0 gas II 1G Ex ia IIC T6...T1 Ga</p> <p>Zone 1 gas II 2G Ex ia IIC T6...T1 Gb</p> <p>Zone mounting to zone 0 gas II 1/2G Ex ia IIC T6...T1 Ga/Gb</p> <p>Zone 20 II 1D Ex ia IIIC T125...T65 °C Da</p> <p>Zone 21 II 2D Ex ia IIIC T125...T65 °C Db</p> <p>Zone 21 mounting to zone 20 dust II 1/2D Ex ia IIIC T125...T65 °C Da/Db</p> <p>- Ex n Zone 2 gas II 3G Ex ex IIC T6...T1 Gc</p> <p>- Ex t Zone 22 dust II 3D Ex tc IIIC TX °C Dc X</p>	

Logo	Description	Region
	<b>INMETRO</b> Hazardous areas - Ex i Zone 0 gas Ex ia IIC T6...T3 Ga Zone 1 mounting to zone 0 gas Ex ia IIC T6...T2 Ga/Gb Zone 20 dust Ex ia IIIC T125...T65 °C Da Zone 21 mounting to zone 20 dust Ex ia IIIC T125...T65 °C Da/Db	Brazil
	<b>CCC<sup>3)</sup></b> Hazardous areas - Ex i Zone 0 gas Ex ia IIC T1...T6 Ga Zone 1 gas Ex ia IIC T1...T6 Gb Zone 1 mounting to zone 0 gas Ex ia IIC T1...T6 Ga/Gb Zone 20 dust Ex ia IIIC T <sub>200</sub> 65°C/T <sub>200</sub> 95°C/T <sub>200</sub> 125°C Da Zone 21 dust Ex ia IIIC T65°C/T95°C/T125°C Db Zone 21 mounting to zone 20 dust Ex ia IIIC T <sub>200</sub> 65°C/T <sub>200</sub> 95°C/T <sub>200</sub> 125°C Da/Db - Ex e Zone 1 gas Ex eb IIC T1...T6 Gb Zone 2 gas Ex ec IIC T1...T6 Gc - Ex t Zone 21 dust Ex tb IIIC T135°C Db Zone 22 dust Ex tb IIIC T135°C Dc	China
	<b>NEPSI<sup>4)</sup></b> Hazardous areas - Ex i Zone 0 gas Ex ia IIC T1 ~ T6 Ga Zone 1 gas Ex ia IIC T1 ~ T6 Gb Zone 1 mounting to zone 0 gas Ex ia IIC T1 ~ T6 Ga/Gb Zone 20 dust Ex iaD 20 T65/T95/T125 Zone 21 dust Ex iaD 21 T65/T95/T125 Zone 21 mounting to zone 20 dust Ex iaD 20/21 T65/T95/T125 - Ex e Zone 2 gas Ex ec IIC T1...T6 Gc - Ex t Zone 22 dust Ex tb IIIC T135°C Dc	China
	<b>KCs</b> Hazardous areas - Ex i Zone 0 gas Ex ia IIC T4/T5/T6 Zone 1 gas Ex ib IIC T4/T5/T6	Korea
-	<b>PESO</b> Hazardous areas - Ex i Zone 0 gas Ex ia IIC T1...T6 Ga Zone 1 gas Ex ia IIC T1...T6 Gb Zone 1 mounting to zone 0 gas Ex ia IIC T1...T6 Ga/Gb	India
	<b>PAC Kazakhstan</b> Metrology, measurement technology	Kazakhstan
-	<b>MChS</b> Permission for commissioning	Kazakhstan
-	<b>PAC Ukraine</b> Metrology, measurement technology	Ukraine
	<b>PAC Uzbekistan</b> Metrology, measurement technology	Uzbekistan

- 1) Only with built-in transmitters
- 2) Only for model BSZ or BSZ-H connection head
- 3) Only without transmitter
- 4) Only with transmitter

Instruments marked with “ia” may also be used in areas only requiring instruments marked with “ib” or “ic”. If an instrument with “ia” marking has been used in an area with requirements in accordance with “ib” or “ic”, it can no longer be operated in areas with requirements in accordance with “ia” afterwards.

The permissible power, Pmax, as well as the permissible ambient temperature, for the respective category can be seen on the Ex certificate or the operating instructions.

The transmitters have their own certificates for hazardous areas. The permissible ambient temperature ranges of the built-in transmitters can be taken from the corresponding transmitter operating instructions and approvals.

## Manufacturer’s information and certificates

Logo	Description
	SIL 2 Functional safety
	NAMUR NE 024 Hazardous areas (Ex i)

## Certificates

Certification type	Measurement accuracy	Material certificate <sup>1)</sup>
<b>2.2 test report</b>	x	x
<b>3.1 inspection certificate</b>	x	x
<b>DAkkS calibration certificate</b>	x	-

1) Thermowells have their own material certificates for selected components

For calibration, the measuring insert is removed from the thermometer. The minimum length (metal part of the probe) for carrying out a 3.1 measurement accuracy test or DAkkS is 100 mm [~ 4 in].

Calibration of shorter lengths as well as calibration of versions in 2-wire connection possible on request.

The different certifications can be combined with each other.

→ For approvals and certificates, see website

# Dimensions in mm [in]

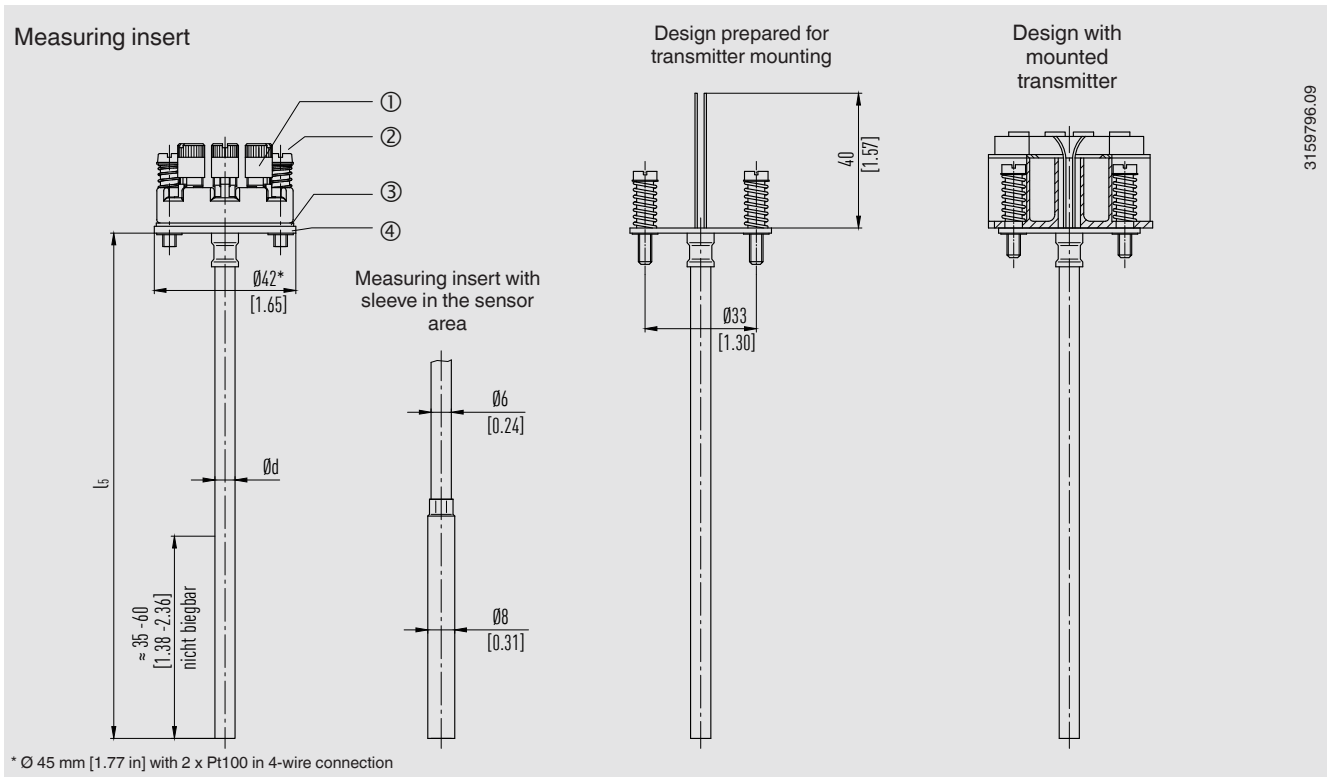

3159796.09

## Legend

- ① Connection terminal
- ② Spring-loaded screw
- ③ Insulation washer
- ④ Terminal plate
- $l_5$  Measuring insert length
- $\varnothing d$  Measuring insert diameter

# Thermowell

## Legend:

$U^1$	Insertion length	$\varnothing F_1$	Thermowell diameter
$l_5$	Measuring insert length	$\varnothing F_3$	Diameter of thermowell tip
$N (M_H)$	Neck length	E	Mounting thread
$K_E$	1/2 NPT: 8.13 mm 3/4 NPT: 8.61 mm	$\varnothing d$	Measuring insert diameter
$C_T$	Thread cable inlet	P	Compression fitting mounting thread

## Thermowell designs

The figures show examples of connection heads.

### Straight thermowell, mounting thread, form 2G DIN 43772

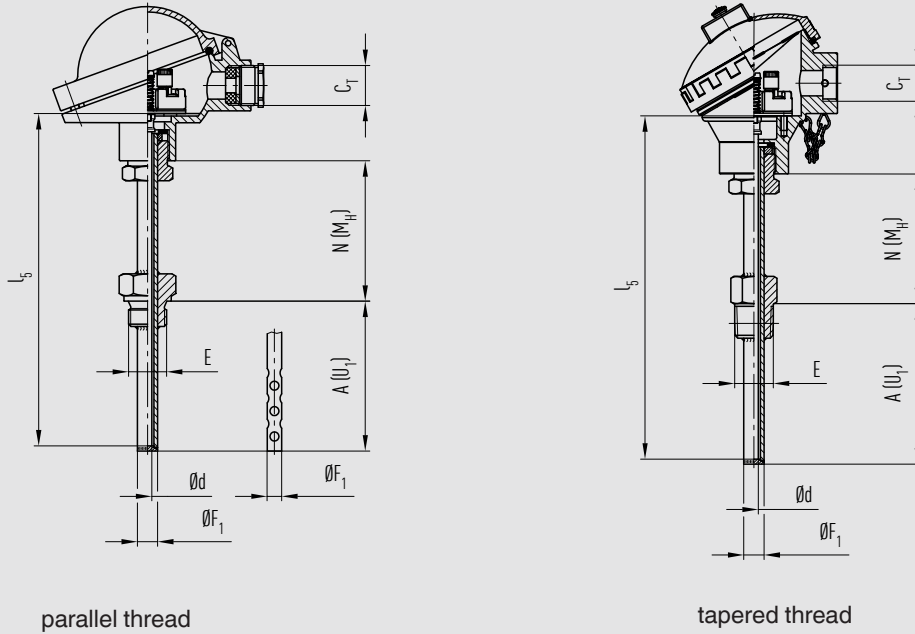

14126798.03

### Straight thermowell, plain, form 2 DIN 43772, with/without compression fitting

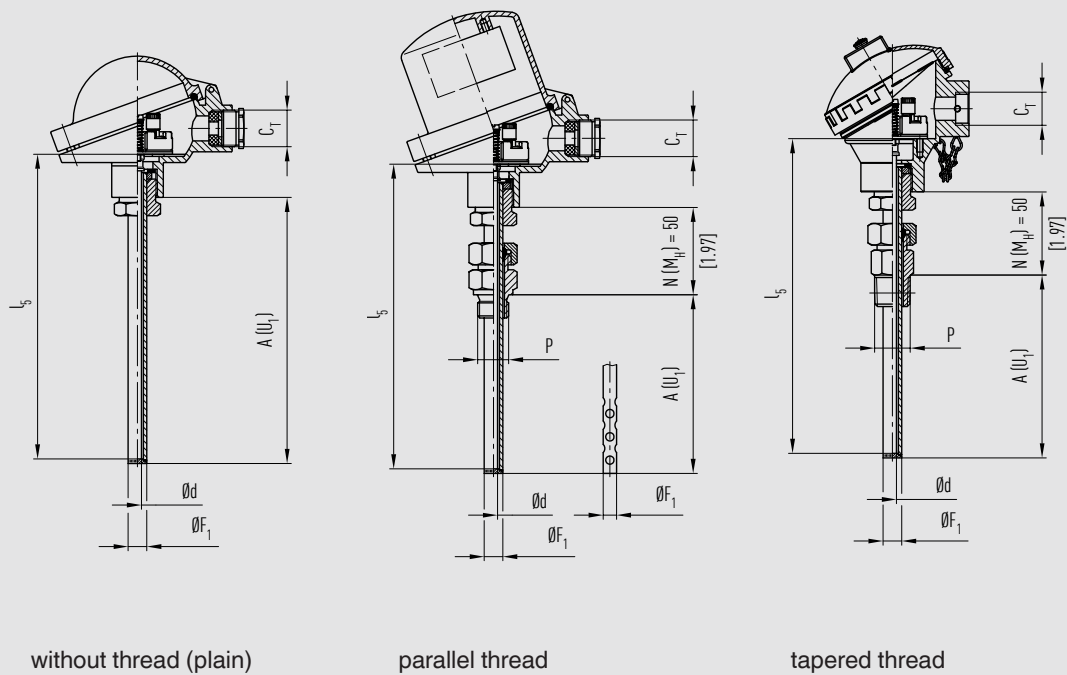

14126798.03

Tapered thermowell, mounting thread, form 3G DIN 43772

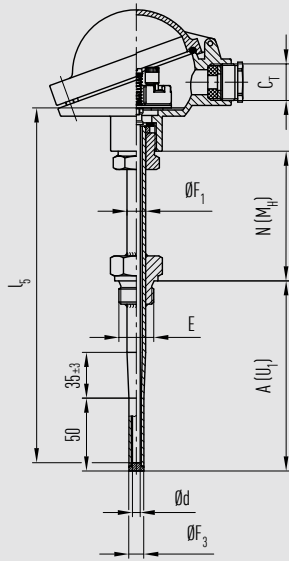

parallel thread

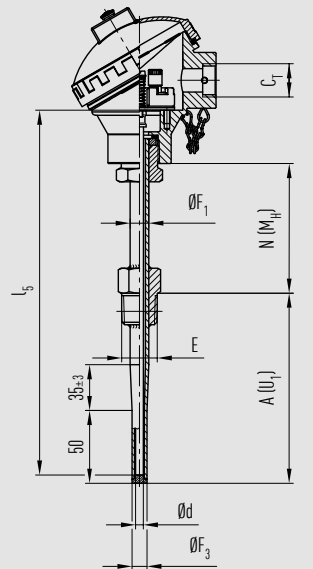

tapered thread

14126834.02

Tapered thermowell, plain, form 3 DIN 43772, with/without compression fitting

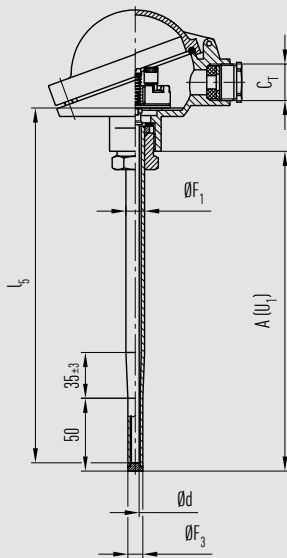

without thread (plain)

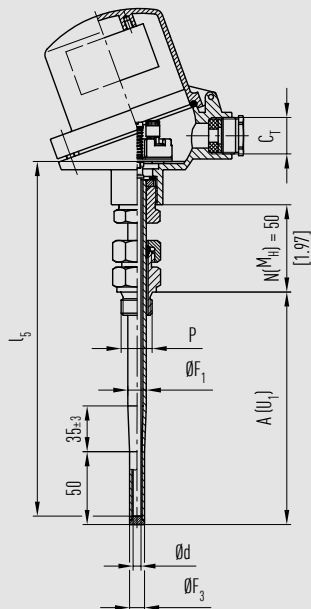

parallel thread

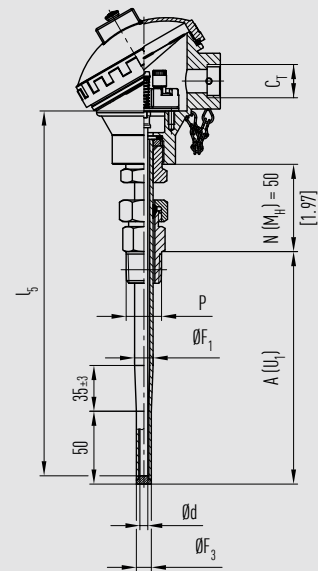

tapered thread

14126834.02

Tapered thermowell, weld-on solid tip, mounting thread, not standardised design

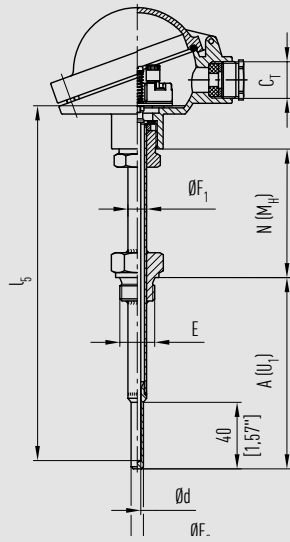

parallel thread

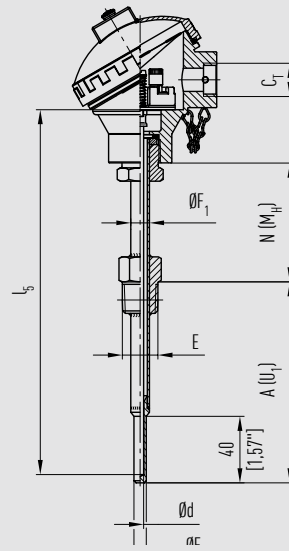

tapered thread

14126855.03

Tapered thermowell, weld-on solid tip, plain, with/without compression fitting

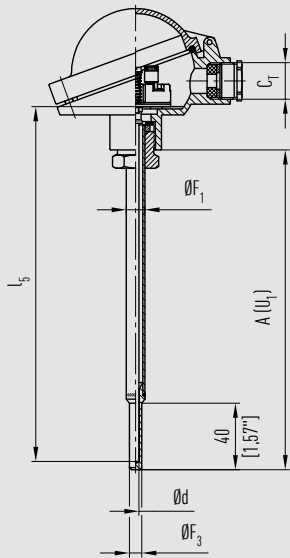

without thread (plain)

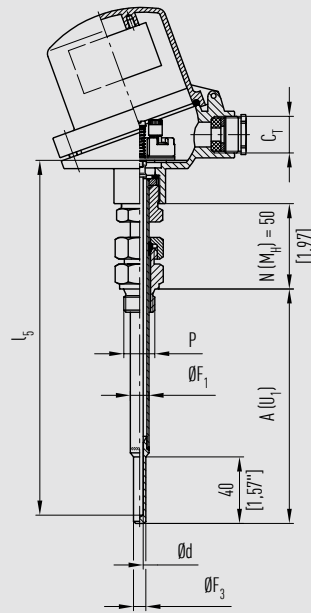

parallel thread

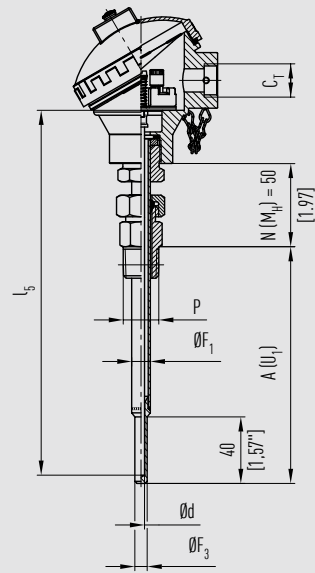

tapered thread

14126855.03



Straight thermowell, hexagonal threaded connection, double threaded hex bushing

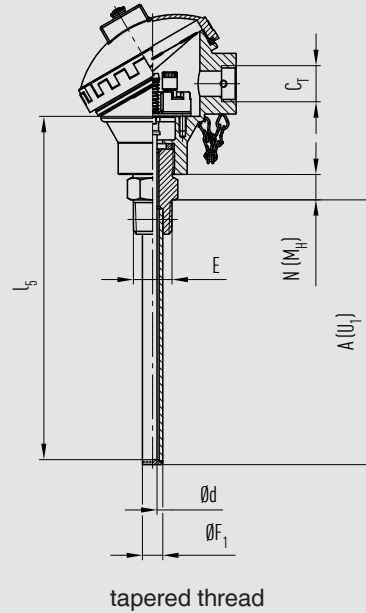
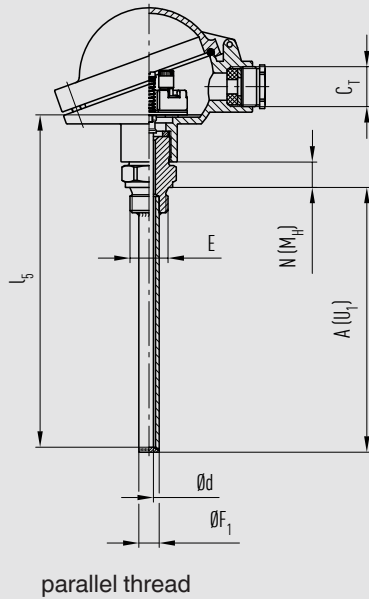

14126798.03

**Ordering information**

Model / Explosion protection / Further approvals, certificates / Sensor / Accuracy class, range of use of the sensor / Connection housing / Cable inlet / Transmitter / Connection to neck tube / Thermowell / Thermowell diameter / Process connection / Thermowell material / Insertion length / Neck length / Certificates / Options



© 04/2003 WIKA Alexander Wiegand SE & Co. KG, all rights reserved.  
 The specifications given in this document represent the state of engineering at the time of publishing.  
 We reserve the right to make modifications to the specifications and materials.  
 In case of a different interpretation of the translated and the English data sheet, the English wording shall prevail.

