

# High-temperature thermocouple Model TC82

WIKA data sheet TE 65.82



For further approvals,  
see page 8

## Applications

- Sulphur recovery units (SRU)
- Chemical, petrochemical industry
- Hot blast stove

## Special features

- Flushing connection to prolong the life of the thermocouple (selectable)
- Increased safety against escape of toxic media through double sealing system
- High variance of thermowell / protection tube materials
- Available with temperature transmitter or field transmitter
- High process safety with processes up to 1,700 °C [3,092 °F]



**High-temperature thermocouple with purge system,  
model TC82-F**

## Description

This high-temperature thermocouple has been specifically developed for use in hazardous applications. A protection tube made from high-temperature ceramic or silicon-carbide, with or without an additional inner tube, protects the thermocouple from the process medium as well as mechanical damage.

For particularly critical applications as e.g. sulphur recovery units, we offer designs with purge gas connection, to prevent the thermocouple by poisoning by the aggressive process atmosphere.

Hermetically sealed junctions prevent toxic gases from being able to escape the reactor. The high temperatures in the process place very high demands on protection tubes and thermocouples. These process conditions often lead to shutdowns and interruptions in operation. The special design of this Ex-approved high-temperature thermometer can significantly improve life expectancy of the thermocouple and reduce downtime.

# Components model TC82

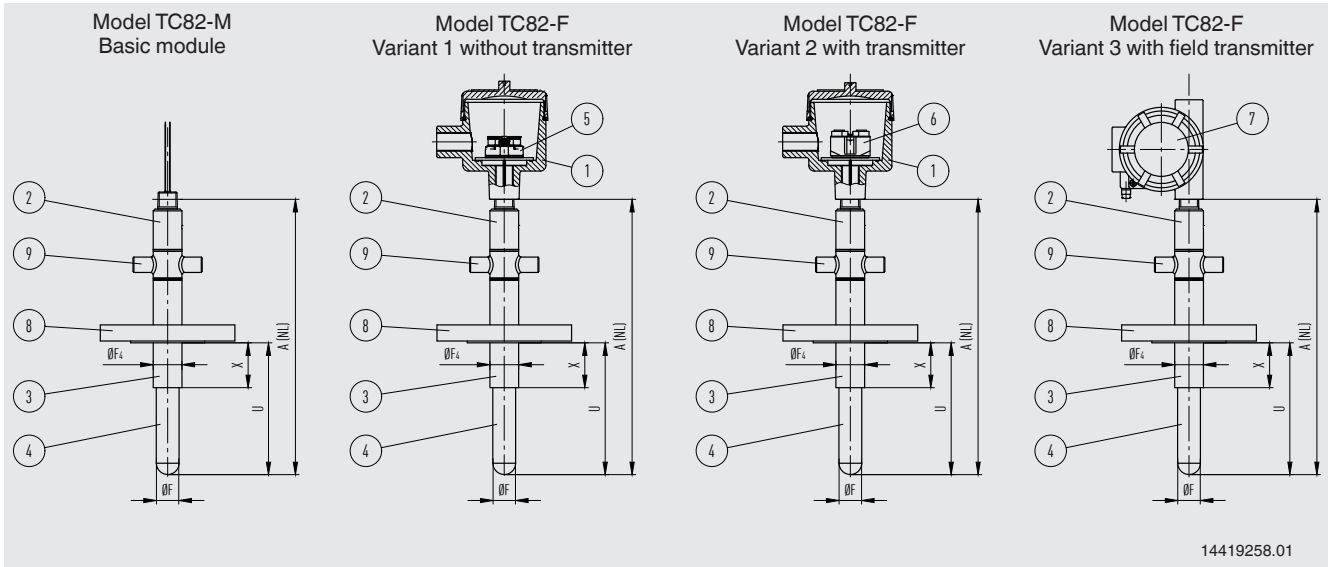

14419258.01

## Legend:

- |                                |  |
|--------------------------------|--|
| ① Connection head              | A (NL) Nominal length                          |
| ② Neck tube                    | U Insertion length                             |
| ③ Metal support tube           | X Support tube length below process connection |
| ④ Thermowell / Protection tube |  |
| ⑤ Terminal block               |  |
| ⑥ Transmitter (selectable)     |  |
| ⑦ Field transmitter            |  |
| ⑧ Process connection           |  |
| ⑨ Purge (selectable)           |  |

## Basic information



### Dimensions

Inner protection tube $\varnothing F_i$	15 x 2 ... 2.5 mm [0.59 x 0.08 ... 0.10 in] → Other diameters on request
Outer protection tube $\varnothing F$	24 ... 26 mm [0.945 ... 1.024 in] → Other diameters on request
Insertion length U	300 ... 1,000 mm [11.81 ... 39.37 in] → Other insertion lengths on request

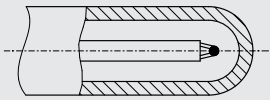
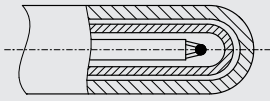
## Measuring element

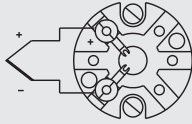
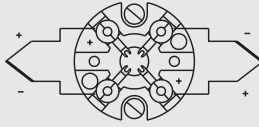
Type of measuring element	Thermocouple per IEC 60584-1 or ASTM E230 Types K, J, E, R, S, B	
Probe tip design (measuring location)		
Set up with a protection tube	<ul style="list-style-type: none"> <li>■ Insulation rod</li> <li>■ Welded thermocouple (measuring location)</li> <li>■ Outer protection tube</li> </ul>	
Set up with outer and inner protection tube	<ul style="list-style-type: none"> <li>■ Insulation rod</li> <li>■ Welded thermocouple (measuring location)</li> <li>■ Inner protection tube</li> <li>■ Outer protection tube</li> </ul>	

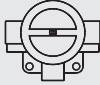
Measuring element		
Marking of the polarity	The colour code at the positive poles of the instrument decides the correlation of polarity and terminal	
Single thermocouple		
Dual thermocouple		
Validity limits of the class accuracy in accordance with IEC 60584-1		
Type K	Class 2	-40 ... +1,200 °C [-40 ... +2,192 °F]
	Class 1	-40 ... +1,000 °C [-40 ... +1,832 °F]
Type J	Class 2	-40 ... +750 °C [-40 ... +1,382 °F]
	Class 1	-40 ... +750 °C [-40 ... +1,382 °F]
Type E	Class 2	-40 ... +900 °C [-40 ... +1,652 °F]
	Class 1	-40 ... +800 °C [-40 ... +1,472 °F]
Type R	Class 2	0 ... 1,600 °C [32 ... 2,912 °F]
	Class 1	0 ... 1,600 °C [32 ... 2,912 °F]
Type S	Class 2	0 ... 1,600 °C [32 ... 2,912 °F]
	Class 1	0 ... 1,600 °C [32 ... 2,912 °F]
Type B	Class 3	600 ... 1,700 °C [1,112 ... 3,092 °F]
	Class 1	600 ... 1,700 °C [1,112 ... 3,092 °F]
Validity limits of the class accuracy in accordance with ASTM E230		
Type K	Standard	0 ... 1,260 °C [32 ... 2,300 °F]
	Special	0 ... 1,260 °C [32 ... 2,300 °F]
Type J	Standard	0 ... 760 °C [32 ... 1,400 °F]
	Special	0 ... 760 °C [32 ... 1,400 °F]
Type E	Standard	0 ... 870 °C [32 ... 1,598 °F]
	Special	0 ... 870 °C [32 ... 1,598 °F]
Type R	Standard	0 ... 1,480 °C [32 ... 2,696 °F]
	Special	0 ... 1,480 °C [32 ... 2,696 °F]
Type S	Standard	0 ... 1,480 °C [32 ... 2,696 °F]
	Special	0 ... 1,480 °C [32 ... 2,696 °F]
Type B	Standard	-
	Special	870 ... 1,700 °C [1,598 ... 3,092 °F]

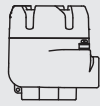
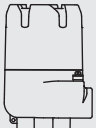
Model		Material	Cable inlet thread size	Ingress protection (max.) <sup>1) 2)</sup> IEC/EN 60529	Cap	Surface	Connection to neck tube
	1/4000 F	Aluminium	<ul style="list-style-type: none"> <li>■ ½ NPT</li> <li>■ ¾ NPT</li> <li>■ M20 x 1.5</li> </ul>	IP66	Screw-on lid	Blue, painted (RAL 5022)	½ NPT
	1/4000 S	Stainless steel	<ul style="list-style-type: none"> <li>■ ½ NPT</li> <li>■ ¾ NPT</li> <li>■ M20 x 1.5</li> </ul>	IP66	Screw-on lid	Natural finish	½ NPT
	5/6000	Aluminium	<ul style="list-style-type: none"> <li>■ 3 x ½ NPT</li> <li>■ 3 x ¾ NPT</li> <li>■ 3 x M20 x 1.5</li> </ul>	IP66	Screw-on lid	Blue, painted (RAL 5022)	½ NPT
	5/6000	Stainless steel	<ul style="list-style-type: none"> <li>■ 3 x ½ NPT</li> <li>■ 3 x ¾ NPT</li> <li>■ 3 x M20 x 1.5</li> </ul>	IP66	Screw-on lid	Natural finish	½ NPT
	7/8000 W	Aluminium	<ul style="list-style-type: none"> <li>■ ½ NPT</li> <li>■ ¾ NPT</li> <li>■ M20 x 1.5</li> </ul>	IP66	Screw-on lid	Blue, painted (RAL 5022)	½ NPT
	7/8000 S	Stainless steel	<ul style="list-style-type: none"> <li>■ ½ NPT</li> <li>■ ¾ NPT</li> <li>■ M20 x 1.5</li> </ul>	IP66	Screw-on lid	Natural finish	½ NPT
	PIH-L	Aluminium	<ul style="list-style-type: none"> <li>■ ½ NPT / closed</li> <li>■ M20 x 1.5 / closed</li> <li>■ 2 x ½ NPT</li> <li>■ 2 x M20 x 1.5</li> </ul>	IP66	Screw-on lid, flat	Blue lid, painted Lower body grey, painted	<ul style="list-style-type: none"> <li>■ ½ NPT</li> <li>■ M20 x 1.5</li> </ul>
	PIH-H	Aluminium	<ul style="list-style-type: none"> <li>■ ½ NPT / closed</li> <li>■ M20 x 1.5 / closed</li> <li>■ 2 x ½ NPT</li> <li>■ 2 x M20 x 1.5</li> </ul>	IP66	Screw-on lid, high	Blue lid, painted Lower body grey, painted	<ul style="list-style-type: none"> <li>■ ½ NPT</li> <li>■ M20 x 1.5</li> </ul>

- 1) IP ingress protection of the connection head. The IP ingress protection of the complete TC83-F instrument does not necessarily have to correspond to the connection head  
2) Suitable sealing / cable gland required..







### Field temperature transmitter, model TIF50 (on request)

As an alternative to the standard connection head, the sensor can also be fitted with an optional model TIF50 field temperature transmitter. A remote version for tube/surface mounting for the sensor designs with connection cable is also possible. The field temperature transmitter comprises a model T38 transmitter with 4 ... 20 mA/HART® protocol output and is equipped with an LCD indication module.



Fig. left: model TIF50, head version  
Fig. right: model TIF50, wall mounting

## Cable inlet

Cable inlet	Colour	Ingress protection (max.) IEC/EN 60529 <sup>1)</sup>	Cable inlet thread size	Min./Max. ambient temperature	
	Natural finish	IP65	<ul style="list-style-type: none"> <li>■ M20 x 1.5</li> <li>■ ½ NPT</li> </ul>	-40 ... +80 °C [-40 ... +176 °F]	
	<ul style="list-style-type: none"> <li>■ Black</li> <li>■ Grey</li> </ul>	IP66	<ul style="list-style-type: none"> <li>■ M20 x 1.5</li> <li>■ ½ NPT</li> </ul>	-40 ... +80 °C [-40 ... +176 °F]	
	<ul style="list-style-type: none"> <li>■ Light blue</li> <li>■ Black</li> </ul>	IP66	<ul style="list-style-type: none"> <li>■ M20 x 1.5</li> <li>■ ½ NPT</li> </ul>	<ul style="list-style-type: none"> <li>■ -20 ... +80 °C [-4 ... +176 °F]</li> <li>■ -40 ... +70 °C [-40 ... +158 °F]</li> </ul>	
	Nickel-plated brass cable gland (cable Ø 6 ... 12 mm)	Natural finish	IP66	<ul style="list-style-type: none"> <li>■ M20 x 1.5</li> <li>■ ½ NPT</li> </ul>	-60 <sup>2)</sup> / -40 ... +80 °C [-76 / -40 ... +176 °F]
	Nickel-plated brass cable gland (cable Ø 6 ... 12 mm), Ex e	Natural finish	IP66	<ul style="list-style-type: none"> <li>■ M20 x 1.5</li> <li>■ ½ NPT</li> </ul>	-60 <sup>2)</sup> / -40 ... +80 °C [-76 / -40 ... +176 °F]
	Stainless steel cable gland (cable Ø 7 ... 12 mm)	Natural finish	IP66	<ul style="list-style-type: none"> <li>■ M20 x 1.5</li> <li>■ ½ NPT</li> </ul>	-60 <sup>2)</sup> / -40 ... +80 °C [-76 / -40 ... +176 °F]
	Stainless steel cable gland (cable Ø 7 ... 12 mm), Ex e	Natural finish	IP66	<ul style="list-style-type: none"> <li>■ M20 x 1.5</li> <li>■ ½ NPT</li> </ul>	-60 <sup>2)</sup> / -40 ... +80 °C [-76 / -40 ... +176 °F]
	Plain threaded	-	IP00	<ul style="list-style-type: none"> <li>■ M20 x 1.5</li> <li>■ ½ NPT</li> </ul>	-
	Sealing plugs for shipping	Transparent	-	<ul style="list-style-type: none"> <li>■ M20 x 1.5</li> <li>■ ½ NPT</li> </ul>	-40 ... +80 °C [-40 ... +176 °F]



1) IP ingress protection of the cable gland. The IP ingress protection of the complete TC82-F instrument does not necessarily have to correspond to the cable gland.

2) Special version on request (explosion-protected versions only available with specific approvals)

Cable inlet	Explosion protection					
	With-out	Ex i (gas) Zone 0, 1, 2	Ex i (dust) Zone 20, 21, 22	Ex e (gas) Zone 1, 2	Ex t (dust) Zone 21, 22	Ex nA (gas) Zone 2
Standard	x	x	-	-	-	-
Plastic cable gland	x	x	-	-	-	-
Plastic cable gland (light blue), Ex e	x	x	x	-	-	-
Plastic cable gland (black), Ex e	x	x	x	x	x	x
Brass cable gland, nickel-plated	x	x	x	-	-	-
Brass cable gland, nickel-plated, Ex e	x	x	x	x	x	x
Stainless steel cable gland	x	x	x	-	-	-
Stainless steel cable gland, Ex e	x	x	x	x	x	x
Plain threaded	x	x	x <sup>1)</sup>	x <sup>1)</sup>	x <sup>1)</sup>	x <sup>1)</sup>
Sealing plugs for shipping	Not applicable, transport protection <sup>1)</sup>					

1) Suitable cable gland required for operation

## Transmitters

Transmitter models	Model T16	Model T38
Transmitter data sheet	TE 16.01	TE 38.01
Figure		
Output		
4 ... 20 mA	x	x
HART® protocol	-	x
Cable inlet	<ul style="list-style-type: none"> <li>■ Type K</li> <li>■ Type J</li> <li>■ Type E</li> <li>■ Type R</li> <li>■ Type S</li> <li>■ Type B</li> </ul>	<ul style="list-style-type: none"> <li>■ Type K</li> <li>■ Type J</li> <li>■ Type E</li> <li>■ Type R</li> <li>■ Type S</li> <li>■ Type B</li> </ul>
Explosion protection	Ex version possible	

Possible connection heads for transmitter mounting	Model T16	Model T38
1/4000	○	○
5/6000	○	○
7/8000	○	○
TIF50	-	○
PIH-L/PIH-H	○	○

Legend:

- Mounted instead of terminal block
- Mounting not possible

The mounting of a transmitter is possible with all the connection heads listed here. For a correct determination of the overall measuring deviation, the sensor and transmitter measuring deviations must be added.

→ For detailed specifications for thermocouples, see IEC 60584-1 or ASTM E230 and Technical information IN 00.23 at [www.wika.com](http://www.wika.com)



In safety-critical applications, the entire measuring chain must be taken into consideration in terms of the safety parameters. The SIL classification allows the assessment of the risk reduction achieved by the safety installations. Selected thermocouples, in combination with a suitable temperature transmitter (e.g. model T38, TÜV-certified SIL version for protection systems developed in accordance with IEC 61508), are suitable as sensors for safety functions to SIL 2. For SIL 3 applications, WIKA recommends the use of two individual thermocouples with one SIL-certified T38 transmitter connected to each.

→ For details, see technical information IN 00.19 on [www.wika.com](http://www.wika.com).

Neck/Support tube	
<b>Versions</b>	
<b>Thread sizes</b>	<ul style="list-style-type: none"> <li>■ M20 x 1.5</li> <li>■ ½ NPT</li> </ul>
<b>Neck/Support tube length N</b>	<ul style="list-style-type: none"> <li>■ Min. 270 mm [10.6 in]</li> <li>■ Min. 300 mm [12 in], for purge connection</li> </ul> → Others on request
<b>Metal support tube Ø F<sub>4</sub></b>	32 mm [1.259 in]

Materials		
<b>Non-wetted</b>		
Neck tube	Stainless steel	
Material of inner protection tube	Ceramic C530	T <sub>max</sub> = 1,600 °C [2,912 °F]
	Ceramic C610	T <sub>max</sub> = 1,500 °C [2,732 °F]
	Ceramic C799	T <sub>max</sub> = 1,600 °C [2,912 °F]
	→ Others on request	
<b>Wetted</b>		
Support tube	<ul style="list-style-type: none"> <li>■ Stainless steel 310</li> <li>■ 446</li> <li>■ Alloy 600</li> </ul>	
Material of outer protection tube	Ceramic C530	T <sub>max</sub> <sup>1)</sup> = 1,600 °C [2,912 °F]
	Ceramic C610	T <sub>max</sub> = 1,500 °C [2,732 °F]
	Ceramic C799	T <sub>max</sub> <sup>1)</sup> = 1,600 °C [2,912 °F]
	Silicon carbide (Hexoloy®)	T <sub>max</sub> <sup>1)</sup> = 1,650 °C [3,000 °F]
	→ Others on request	

1) Upper operating temperature in air up to 1,700 °C [3,082 °F]

Process connection	
<b>Standard</b>	<ul style="list-style-type: none"> <li>■ ASME</li> <li>■ EN 1092-1</li> </ul>
<b>Nominal size</b>	
ASME	1.5 ... 6"
EN 1092-1	DN40 ... DN100
<b>Pressure ratings</b>	
ASME	150 ... 1,500 lbs
EN 1092-1	PN 40 ... PN 100
<b>Sealing face</b>	
ASME	Stock finish (125 ... 250 AARH)
EN 1092-1	Form B1 (R <sub>a</sub> 3.2 ... 12.5 µm)

→ Other process connections on request





Operating conditions	
<b>Operating temperature</b>	
Ceramic protection tube	Max. 1,700 °C [3,082 °F] → Others on request
<b>Ambient and storage temperature range</b>	-60 <sup>1)</sup> / -40 ... +80 °C [-76 <sup>1)</sup> / -40 ... +176 °F]
<b>Pressure limitation</b>	Max. 1.5 bar [22 psi]

1) Special version on request (only available with specific approvals)

## Approvals

Logo	Description	Region
	<b>EU declaration of conformity</b>	European Union
	EMC directive EN 61326 emission (group 1, class B) and immunity (industrial environments)	
	RoHS directive	

## Optional approvals

Logo	Description	Region
	<b>EU declaration of conformity</b>	European Union
	ATEX directive Hazardous areas - Ex d Zone 1 gas Zone 1 gas II 2/-G Ex db IIC T6 ... T1 Gb/- II 2/-G Ex db IIC Gb/- - Ex i Zone 1 gas Zone 21 dust Zone 1 gas Zone 21 dust II 2/- G Ex ia IIC T* Gb/- II 2/- D Ex ia IIIC T* Db/- II 2/- G Ex ia IIC Gb/- II 2/- D Ex ia IIIC Db/-	
	<b>IECEx</b> Hazardous areas - Ex d Zone 1 gas Zone 1 gas Ex db IIC T6 ... T1 Gb/- Ex db IIC Gb/- - Ex i Zone 1 gas Zone 21 dust Zone 1 gas Zone 21 dust Ex ia IIC T* Gb/- Ex ia IIIC T* Db/- Ex ia IIC Gb/- Ex ia IIIC Db/-	International
	<b>EAC</b> Hazardous areas - Ex d Zone 1 gas - Ex i Zone 21 dust Zone 1 gas 1Ex d IIC T6...T1 Gb X Ex ia IIIC T135°C Db X 1Ex ia IIC T6...T1 Gb X	
	<b>EAC</b> Hazardous areas - Ex d Zone 1 gas - Ex i Zone 21 dust Zone 1 gas 1Ex d IIC T6...T1 Gb X Ex ia IIIC T135°C Db X 1Ex ia IIC T6...T1 Gb X	Eurasische Wirtschaftsge- meinschaft
	<b>PAC Kazakhstan</b> Metrology, measurement technology	Kazakhstan
-	<b>PAC Ukraine</b> Metrology, measurement technology	Ukraine
	<b>PAC Uzbekistan</b> Metrology, measurement technology	Uzbekistan



# Certificates

Certificates	
Certificates	<ul style="list-style-type: none"> <li>■ 2.2 test report per EN 10204 (e.g. state-of-the-art manufacturing, material proof, indication accuracy)</li> <li>■ 3.1 inspection certificate per EN 10204 (e.g. material proof for wetted metal parts, indication accuracy, calibration certificate)</li> <li>■ Calibration at 3 test points (900 °C, 1,000 °C and 1,100 °C [1,652 °F, 1,832 °F and 2,012 °F])</li> <li>■ Calibration at 3 test points (1,000 °C, 1,200 °C and 1,400 °C [1,832 °F, 2,192 °F and 2,552 °F])</li> </ul>

→ For approvals and certificates, see website

## Manufacturer's information and certificates

Logo	Description
	SIL 2 Functional safety

## Dimensions in mm [in]

Legend:

- A Nominal length
- U Insertion length
- N Neck tube / Support tube length
- X Neck tube / Support tube length below process connection
- $\varnothing F_i$  Diameter of the inner protection tube
- $\varnothing F_4$  Support tube diameter
- $\varnothing F$  Diameter of outer protection tube

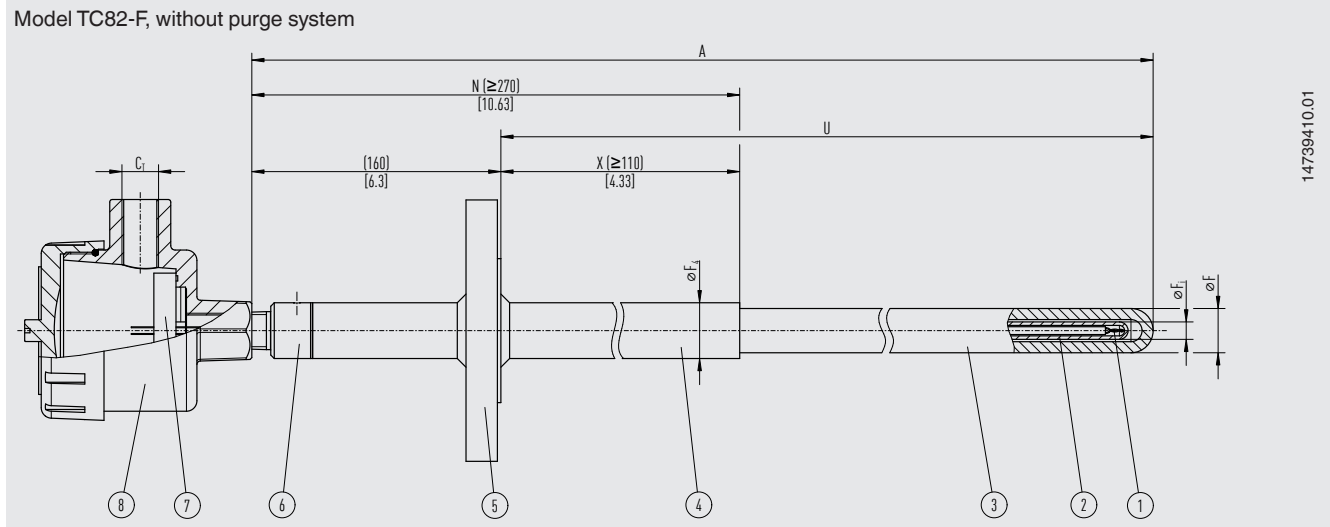

- ① Thermocouple
- ② Ceramic inner protection tube
- ③ Ceramic outer protection tube
- ④ Metal support tube
- ⑤ Process connection
- ⑥ Neck tube
- ⑦ Terminal block / Transmitter (selectable)
- ⑧ Connection head

Model TC82-F, with purge system

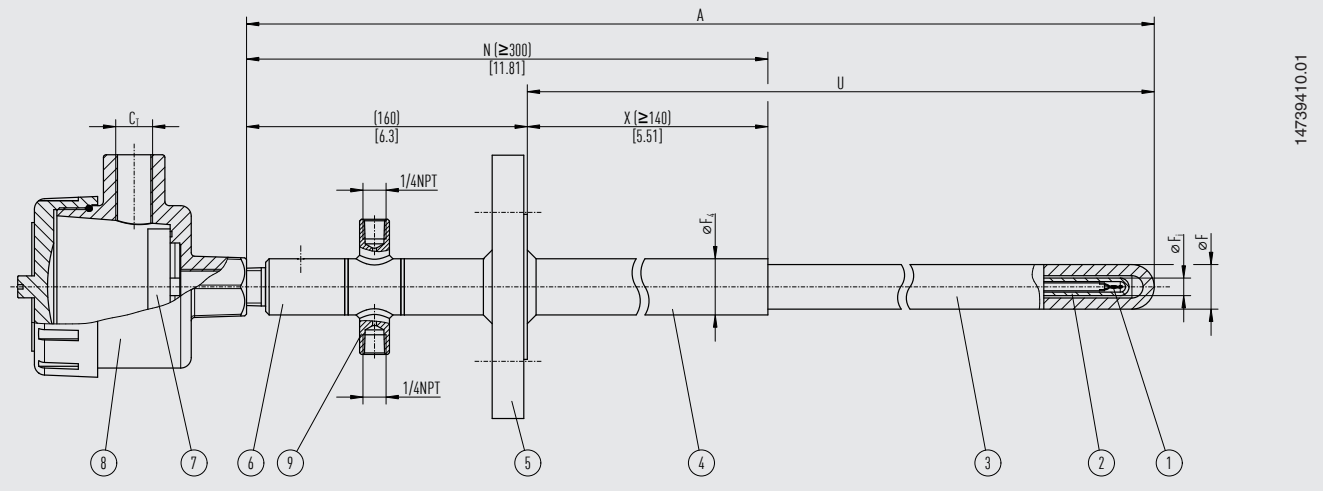

14739410.01

- ① Thermocouple
- ② Ceramic inner protection tube
- ③ Ceramic outer protection tube
- ④ Metal support tube
- ⑤ Process connection
- ⑥ Neck tube
- ⑦ Terminal block / Transmitter (selectable)
- ⑧ Connection head
- ⑨ Purge connection ¼ NPT

### Ordering information

Model / Explosion protection / Ignition protection mode / Sensor / Sensor specifications / Measuring location / Connection housing / Thread size at cable outlet / Cable outlet / Transmitter / Support tube version / Connection to case, connection head / Process connection / Outer protection tube / Inner protection tube / Neck/Support tube length N / Support tube length (process side) X / Insertion length U / Nominal length A / Options

© 07/2021 WIKA Alexander Wiegand SE & Co. KG, all rights reserved.  
 The specifications given in this document represent the state of engineering at the time of publishing.  
 We reserve the right to make modifications to the specifications and materials.  
 In case of a different interpretation of the translated and the English data sheet, the English wording shall prevail.

