

Precision Pressure Transducer

CPT6100 - CPT6180





Warning

This Warning symbol indicates that danger of injury for persons and the environment and/or considerable damage (mortal danger, danger of injury) will occur if the respective safety precautions are not taken.



Caution

This Caution symbol indicates danger for the system and material if the respective safety precautions are not taken.



Notice

This Notice symbol does not indicate safety notices but information for a better understanding of the facts.

Contents

1.	General Information	5
1.1	Warranty	5
1.2	Important Notice	5
1.3	Software License Agreement	6
1.4	Mensor Service Plus	6
1.4.1	After the Warranty	6
1.4.2	Calibration Services	6
1.4.3	Certifications and Accreditations	6
2.	Safety Notices	7
2.1	Warnings and Caution Notices	7
3.	Product Description	8
3.1	General Description	8
3.2	Turndowns	8
3.3	Power Supply	8
3.4	Sensor	8
3.5	Circuitry	8
3.6	Serial In/Out Communications	9
4.	Specifications	10
5.	Installation	12
5.1	Unpacking the instrument	12
5.2	Dimensions	12
5.3	Configuration	12
5.4	Mounting	12
5.5	Pressure Connections	13
5.6	Electrical Connections	13
5.6.1	Connector J1 Wiring	14
5.6.2	RS-232 Operation	14
5.6.3	RS-485 Operation	14

Digital Pressure Transducer

CPT6100 - CPT6180

6.	Operation	16
6.1	Multiple Turndown Devices	16
6.1.1	Filter Effects of Multiple Turndowns	16
6.2	Serial Port Configuration	17
6.3	CPT6100 Address	17
6.4	Communication Syntax and Command Conventions	17
6.4.1	Wildcard Address Operator (*)	18
6.4.2	Password Protection	18
6.4.3	Response String Format	18
6.4.4	Commands and Queries	19
6.4.5	Units Codes and Conversions	20
7.	Analog Output (Option)	22
7.1	Analog Output Option	22
7.1.1	Serial Commands for Analog Output	22
7.1.2	Zero and Span Adjustment	23
7.1.3	Specifications	23
8.	Calibration	24
8.1	Environment	24
8.2	Equipment	24
8.3	Pressure Standard	26
8.4	Calibration Medium	26
8.5	Calibration Process	26
8.6	Correction Value Query	27
8.7	Zero Adjustment	27
8.7.1	Gauge Zero Offset	27
8.7.2	Absolute Zero Offset	28
8.8	Span Adjustment	29
9.	Accessories	30
9.1	Fittings & Gaskets	30
9.2	Accessories	30

1. General Information

1.1 Warranty

All products manufactured by Mensor are warranted to be free of defects in workmanship and materials for a period of one year from the date of shipment. No other express warranty is given, and no affirmation of Seller, by words or actions, shall constitute a warranty. SELLER DISCLAIMS ANY IMPLIED WARRANTIES OF MERCHANTABILITY OR FITNESS FOR ANY PARTICULAR PURPOSES WHATSOEVER. If any defect in workmanship or material should develop under conditions of normal use and service within the warranty period, repairs will be made at no charge to the original purchaser, upon delivery of the product(s) to the factory, shipping charges prepaid. If inspection by Mensor or its authorized representative reveals that the product was damaged by accident, alteration, misuse, abuse, faulty installation or other causes beyond the control of Mensor, this warranty does not apply. The judgment of Mensor will be final as to all matters concerning condition of the product, the cause and nature of a defect, and the necessity or manner of repair. Service, repairs or disassembly of the product in any manner, performed without specific factory permission, voids this warranty.

MENSOR MAKES NO WARRANTY OF ANY KIND WITH REGARD TO THIS MANUAL, INCLUDING, BUT NOT LIMITED TO, THE IMPLIED WARRANTIES OF MERCHANTABILITY AND FITNESS FOR A PARTICULAR PURPOSE. Mensor shall not be liable for errors contained herein or for incidental or consequential damages in connection with the furnishing, performance, or use of this material.

1.2 Important Notice

The product specifications and other information contained in this manual are subject to change without notice.

Mensor has made a concerted effort to provide complete and current information for the proper use of the equipment. If there are questions regarding this manual or the proper use of the equipment, contact either Mensor or WIKA:

Mensor
201 Barnes Drive
San Marcos, TX 78666
tel: 1-512-396-4200
1-800-984-4200 (USA only)
website: www.mensor.com
fax: 1-512-396-1820
email: sales@mensor.com
tech.support@mensor.com

WIKA Alexander Wiegand SE & Co. KG
Alexander-Wiegand-Straße 30
D-63911 Klingenberg / Germany
tel: (+49) 93 72/132-5015
website: www.wika.de
fax: (+49) 93 72/132-8767
email: CTsales@wika.com

Any reproduction of this manual or parts thereof by any means is prohibited.
Copyright © 2005, Mensor. All rights reserved.

Digital Pressure Transducer CPT6100 - CPT6180

1.3 Software License Agreement

This product contains intellectual property, i.e., software programs, that are licensed for use by the end user/customer (hereinafter “end user”).

This is not a sale of such intellectual property.

The end user shall not copy, disassemble or reverse compile the software program.

THE SOFTWARE PROGRAMS ARE PROVIDED TO THE END USER “AS IS” WITHOUT WARRANTY OF ANY KIND, EITHER EXPRESS OR IMPLIED, INCLUDING, BUT NOT LIMITED TO, WARRANTIES OF MERCHANTABILITY AND FITNESS FOR A PARTICULAR PURPOSE. THE ENTIRE RISK OF THE QUALITY AND PERFORMANCE OF THE SOFTWARE PROGRAM IS WITH THE END USER.

MENSOR AND ITS SUPPLIERS SHALL NOT BE HELD TO ANY LIABILITY FOR ANY DAMAGES SUFFERED OR INCURRED BY THE END USER (INCLUDING, BUT NOT LIMITED TO, GENERAL, SPECIAL, CONSEQUENTIAL OR INCIDENTAL DAMAGES INCLUDING DAMAGES FOR LOSS OF BUSINESS PROFITS, BUSINESS INTERRUPTION, LOSS OF BUSINESS INFORMATION AND THE LIKE), ARISING FROM OR IN CONNECTION WITH THE DELIVERY, USE OR PERFORMANCE OF THE SOFTWARE PROGRAM.

1.4 Mensor Service Plus

If you have problems and you don't find the answer in this manual, contact Mensor at 1.800.984.4200 (USA only) or 1.512.396.4200 for personal assistance, or at any of the contact addresses listed on the rear cover of this manual. We are ready to help.

Service Center USA Mensor website: www.mensor.com tel: 1-512-396-4200 1-800-984-4200 fax: 1-512-396-1820 email: tech.support@mensor.com	Service Center Europe WIKA Alexander Wiegand SE & Co. KG website: www.wika.de / www.wika.com tel: (+49) 9372 132-0 fax: (+49) 9372 132-406 email: CTServiceTeam@wika.com
Service Center China WIKA China website: www.wika.cn contact: Baggio Li tel: (+86) 512 6878 8000 fax: (+86) 512 6809 2321 email: baggio.li@wika.com	WIK A Instrumentation PTE. LTD. WIK A Instrumentation PTE. LTD. 13 Kian Teck Crescent 628878 Singapore Tel: +65 6844 5506 E-mail: info@wika.sg

1.4.1 After the Warranty

Mensor's concern with the performance of this instrument is not limited to the warranty period. We provide complete repair, calibration and certification services after the warranty for a nominal fee.

1.4.2 Calibration Services

In addition to servicing our own products Mensor can perform a complete pressure calibration service, up to 30,000 psi, for all of your pressure instruments. This service includes an accredited calibration.

1.4.3 Certifications and Accreditations

Mensor is registered to ISO 9001:2008. The calibration program at Mensor is accredited by A2LA, as complying with both the ISO/IEC 17025:2005 and the ANSI/NCSL Z540-1-1994 standards.

2. Safety Notices

2.1 Warnings and Caution Notices



Warning

WARNING: Not explosion proof. Installation of this instrument in an area requiring devices rated as intrinsically safe is not recommended.



Warning

WARNING: INJURY THROUGH IMPROPER USE! Do not use the transducer with materials and mixtures of the group 1 (hazardous fluids) according Regulation (EC) no. 1272/2008.



Caution

CAUTION: Some ranges require clean, dry, non-corrosive pressure media. See “Media Compatibility” in the Specifications section of this manual. This instrument is not designed for oxygen use.



CAUTION: ESD PROTECTION REQUIRED. The proper use of grounded work surfaces and personal wrist straps are required when coming into contact with exposed circuits (printed circuit boards) to prevent static discharge to sensitive electronic components.



Caution

CAUTION: Avoid excessive overpressure to the sensor. Externally mounted relief valves to provide overpressure protection are available from Mensor as optional devices and are highly recommended for very low pressure transducers.

3. Product Description

3.1 General Description

The CPT6100 and the CPT6180 Digital Pressure Transducers are self-contained pressure sensing device that provides high accuracy pressure measurements. These transducers incorporate a low hysteresis silicon sensor with electronically compensated pressure linearity over the specified temperature range. Communication with the CPT6100 and CPT6180 is over a serial bus, either RS-232 or RS-485. Differences between the two products can be seen in the specification section.

3.2 Turndowns

The transducer has the capability to include two distinct ranges (turndowns) using a single sensor. The primary turndown is always the higher range of the transducer. At powerup the primary turndown is active by default.

3.3 Power Supply

The required 12VDC power enters via J1. The power supply used to power the device must be a limited-energy device supplying less than 8.3A at 12VDC. It is recommended that the power supply is IEC6010-1 3rd ed. compliant.

3.4 Sensor

The pressure sensor is a micromachined silicon strain gauge. The sensor is secured to the transducer case.

3.5 Circuitry

All of the circuitry is included on a single PC board. The combined pressure and temperature sensor signals are routed to the signal conditioning electronics.

3.6 Serial In/Out Communications

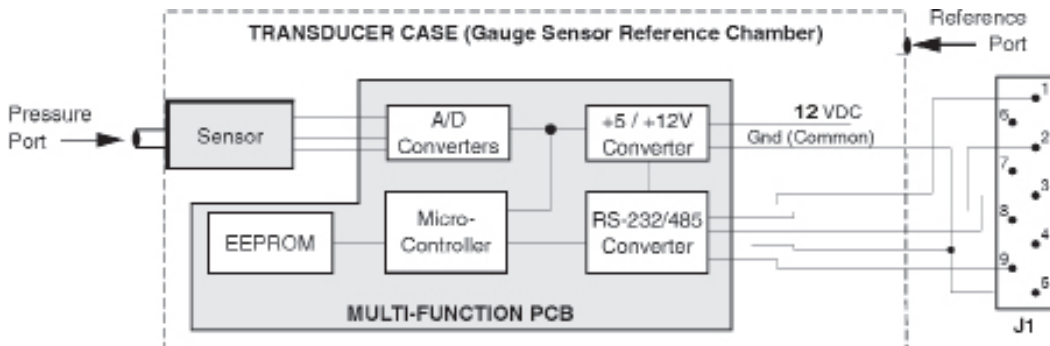

Figure 3.6 - Serial In/Out Communications

The serial bus is set to either RS-232 or RS-485 at the factory. The bus is a two way communication path used to receive commands and return measured pressure values and other transducer information to the user. This port is also used to transmit calibration adjustments and other user functions to the transducer. Pressure units for each transducer are specified by the customer. Wiring requirements for the serial port are provided in the Installation section and a list of valid commands and responses (Table 6.4.4) is provided in the operation section.

4. Specifications

Accuracy specifications presented herein are obtained by comparison with primary standards traceable to the National Institute of Standards and Technology (NIST) or equivalent certifying body. These specifications are obtained in accordance with the ISO Guide to the Expression of Uncertainty in Measurement (GUM). The calibration program at Mensor is accredited by the American Association of Laboratory Accreditation (A2LA) as complying with both the ISO/IEC 17025:2017 and the ANSI/NCSL Z540-1-1994 standards.

Mensor reserves the right to change specifications without notice.

CPT6100 Pressure Ranges	Gauge: 0 ... 0.36 to 0 ... 6000 psig Absolute ⁽¹⁾ : 0 ... 7.5 to 0 ... 6015 psia Bi-directional: -0.18 ... +0.18 psi to -atm ... 6,000 psi
CPT6100 Accuracy ⁽²⁾	0.01% FS ⁽³⁾
CPT6180 Pressure Ranges	Gauge: 0 ... 14.5 to 0 ... 6000 psig ⁽⁴⁾ Absolute ⁽¹⁾ : 0 ... 14.5 to 0 ... 6015 psia Bi-directional: -15 ... 145 psi to -15 ... 6000 psi ⁽⁴⁾
CPT6180 Accuracy ⁽²⁾	0.01% IS-50 ⁽⁵⁾
Precision ⁽⁵⁾	0.004% FS
Calibration Stability (after warm-up)	Better than 0.010% FS for 180 days with periodic re-zeroing.
Calibration Interval	CPT6100 - 180 days, CPT6180 - 365 days.
Calibration Adjustments	Zero and Span via the serial interface
Pressure Units	psi, inHg @ 0°C and 60°F, inH2O @ 4°C, 20°C and 60°F, ftH2O @ 4°C, 20°C and 60°F, mTorr, inSW @ 0°C, ftSW @ 0°C, ATM, bars, mbars, mmH2O @ 4°C, cmH2O @ 4°C, MH2O @ 4°C, mmHg @ 0°C, cmHg @ 0°C, Torr, hPa, mPa, kPa, Pa, D/cmsq, g/cmsq, kg/cmsq, mSW @ 0°C, OSI, PSF, TSF, TSI, mHg @ 0°C, %FS. All seawater units are 3.5% salinity.
Resolution	CPT6100 - 6 digits, CPT6180 - 7 digits
Overpressure Limit	150% FS or greater, depending on range
Compensated Temperature Range	15 ... 45 °C (59 ... 113 °F)
Operating Temperature Range	0 ... 50°C (32 ... 122 °F)
Storage Temperature Range	-20 ... 70 °C (-4 ... 158 °F)
Humidity	0 ... 95% r.h. (non-condensing)
Operating Altitude	<3048 meters (10,000 ft)
Warm-up Time	15 minutes
Reading Rate	Standard: 50 Hz/ 20 ms Optional: 10 Hz/ 100 ms

Noise	<p>Filter set to 90% (factory default): 20 ppm peak-to-peak and 6.5 ppm rms.</p> <p>Filter set to 0%: 53 ppm p-p and 12.5 ppm rms.</p> <p>Filter set to 99%: 13 ppm p-p and 4.2 ppm rms.</p>
Orientation Effects	< 15 psi, orientation must be specified
Communications	RS-232 or RS-485. From 9600 to 56k baud.
Case Size	See "5.2 - Dimensions"
Weight	Approximately 17.8 ounces (505 grams)
Media Compatibility	Clean, dry, non-corrosive gases for ranges <15 psi. All other ranges compatible with aluminum, 316SS, brass, Buna-N, Viton®, sealant, and silicone grease. Not designed for oxygen use.
Power	+12 VDC ±10%, 55 mA max
Mechanical Shock	3g max
Multi-drop Capacity	The maximum number of RS-485 transducers which can be connected to a single host computer is 31.
Compliance	Compliant to the following CE Standards: EN 50081-1, EN 50082-1, EN 50081-2, EN 50082-2.
CPT6100 Only - Optional Output	Analog: 0-1, 0-5, and 0-10 VDC

⁽¹⁾ The minimum calibrated range of absolute transducer(s) is 600 mTorr

⁽²⁾ It is defined by the total measurement uncertainty, with the coverage factor ($k = 2$) and includes the intrinsic performance of the instrument, the measurement uncertainty of the reference instrument, long-term stability, influence of ambient conditions, drift and temperature effects over the compensated range with recommended zero point adjustment every 30 days.



⁽³⁾ FS = full span.

⁽⁴⁾ Ranges from 1500 to 2000 psig will be sealed gauge transducers.

⁽⁵⁾ 0.01 % IS-50 accuracy: Between 0 ... 50 % of the full scale, the accuracy is 0.01% of half of the full scale value and between 50 ... 100 % of the full scale, the accuracy is 0.01 % of reading.

⁽⁶⁾ It is defined as the combined effects of linearity, repeatability and hysteresis throughout the stated compensated temperature range.

Approvals and Certificates

Logo	Description	Country
	<p>EU Declaration of Conformity EU Importer: WIKA, 63911 Klingenberg, Germany</p>	European Union
	<p>UKCA Declaration of Conformity Importer: WIKA Instruments Ltd, Unit 6 & 7 Goya Business Park, The Moor Road, Sevenoaks Kent, TN15 5GY</p>	Great Britain

Certificates

Calibration	<p>Standard: A2LA accredited calibration certificate (standard on factory) Optional: DKD/DAkkS calibration certificate</p>
-------------	--

5. Installation

5.1 Unpacking the instrument

In addition to functional testing, each unit is inspected for appearance prior to leaving the factory. Upon receipt, please examine the transducer for shipping damage. Report any apparent damage to the carrier immediately.

In addition to this manual and password information (files on USB drive) you should have:

- One Digital Pressure Transducer
- Any accessories ordered
- An envelope containing a Calibration Certificate

Note: The software utility is downloadable from the Mensor website (see Section 8.2, "Equipment").

5.2 Dimensions

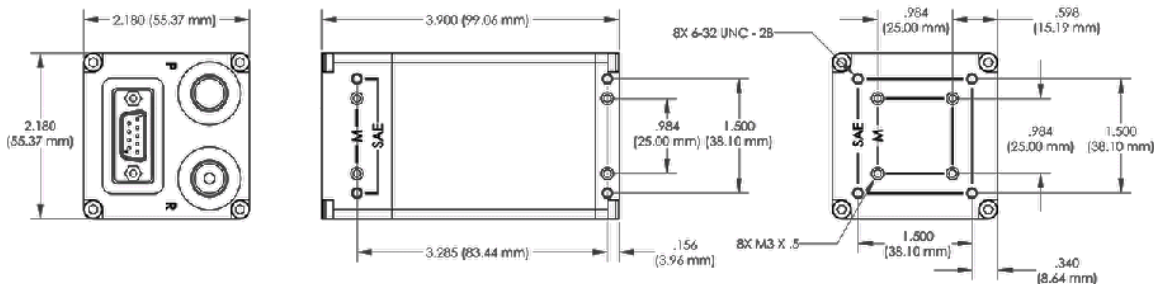

Mounting holes dimension could vary, slotted mounting holes are recommended.

5.3 Configuration

A typical system will consist of an IBM-PC compatible computer with installed driver software, one or more CPT61XX's, a DC voltage power supply, and the interconnecting cables. The driver software can be any program configured to operate the appropriate serial interface. Up to 31 CPT61XX's can be connected in parallel using RS-485. Refer to Figure 5.6.3 for an illustration of two alternate RS-485 wiring arrangements, including multiple CPT61XX operation.

5.4 Mounting

The CPT61XX has mounting holes on the side and back per the drawing in 5.2 Dimensions. The CPT61XX can be set up in any orientation since the pressure sensor is relatively insensitive to tilt and vibration. However, excessive motor or machinery vibration of the mounting surface should be avoided to further ensure stability and accuracy. For the greatest accuracy on transducers with a full scale range of less than 15 psi, set CPT61XX zero while it is oriented in its operational position.

5.5 Pressure Connections

The pressure to be measured is applied to the port labeled P on top of the CPT61XX. The reference connection for gauge pressure is made to the port labeled R. On gauge transducers the reference port is normally left open to atmosphere. If the transducer is used in a differential mode, static line pressures may affect the calibration.

5.6 Electrical Connections

Figure 5.6 - RS-232 Hookup

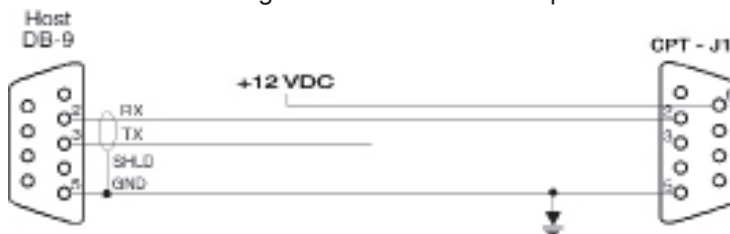

Notice

1. Connectors are female, shown from the wired end.
2. See Table 5.6 for a complete listing of the DB-9 connections.

Table 5.6 - DB-9 Connections

Pin #	RS-232	RS-485
1	N.C.	TA
2	TX	RB
3	RX	RA
4	ANA-	ANA-
5	PWR GND	PWR GND
6	+12 VDC	+12VDC
7	ANA+	ANA+
8	+5Vin	+5Vin*
9	N.C.	TB

* Use of +5 VDC to power the CPT61XX is not recommended. If required, please consult Mensor for specific power requirements.

5.6.1 Connector J1 Wiring

Power and signals are applied to J1, a 9-pin D-sub male connector. A nominal 12 VDC supply can be used to power the CPT61XX by applying 12 VDC to pin 6 and ground to pin 5. Power consumption is maximum 55mA at 12 VDC. The CPT61XX is protected against power input reversal. Communication wiring between the host and the CPT61XX is shown in Figures 5.6 and 5.6.3.

5.6.2 RS-232 Operation

For RS-232 serial port operation connect the CPT61XX to the host computer. Notice that the host TRANSMIT line is connected to the CPT61XX RECEIVE line (TX to RX), and vice versa. One limitation of the RS-232 bus is that a host can support only one instrument. See “RS-485 Operation” for multiple CPT61XX operation.

5.6.3 RS-485 Operation

For RS-485 serial operation, connect the host computer to the CPT61XX per the wire diagram shown in Figure 5.6.3. Notice that the host TRANSMIT lines are connected to the CPT61XX RECEIVE lines, TA to RA, TB to RB, and so on.

If only one RS-485 CPT61XX will be connected to the system, disregard the wiring to “CPT61XX #1” and “CPT61XX #2” in the illustrations. Instead, wire the computer directly to the “CPT61XX #31” by the four-wire method.



Caution

If using a multidrop RS-485 connection, pins 4, 7 and 8 must not be daisy chained.

To connect multiple RS-485 CPT61XX's to a single host, use the full multi-drop wiring shown in Figure 5.6.3. Only full duplex (4-wire) connection is recommended. In this configuration, one computer can communicate with up to 31 CPT61XX's without a repeater, but each CPT61XX in the system must have a unique address. The signal is simultaneously distributed to each transducer connected to the parallel path. Each CPT61XX responds only to commands or queries directed to its own address. Removal of one or more CPT61XX's from the line has no effect on the remaining devices.

Terminating resistor examples are shown and should be determined by the end user when cabling extremes are required. Resistor values are selected to match the characteristic impedance of the transmission line, typically 100 to 120 ohms.



Caution

Due to the nature of the various RS-485 converters available there may be communication issues. We have determined that our devices work with the ACCES I/O PRODUCTS devices. At this time we are not in a position to comment on any other make of RS-485 converters and their suitability for use with our products.

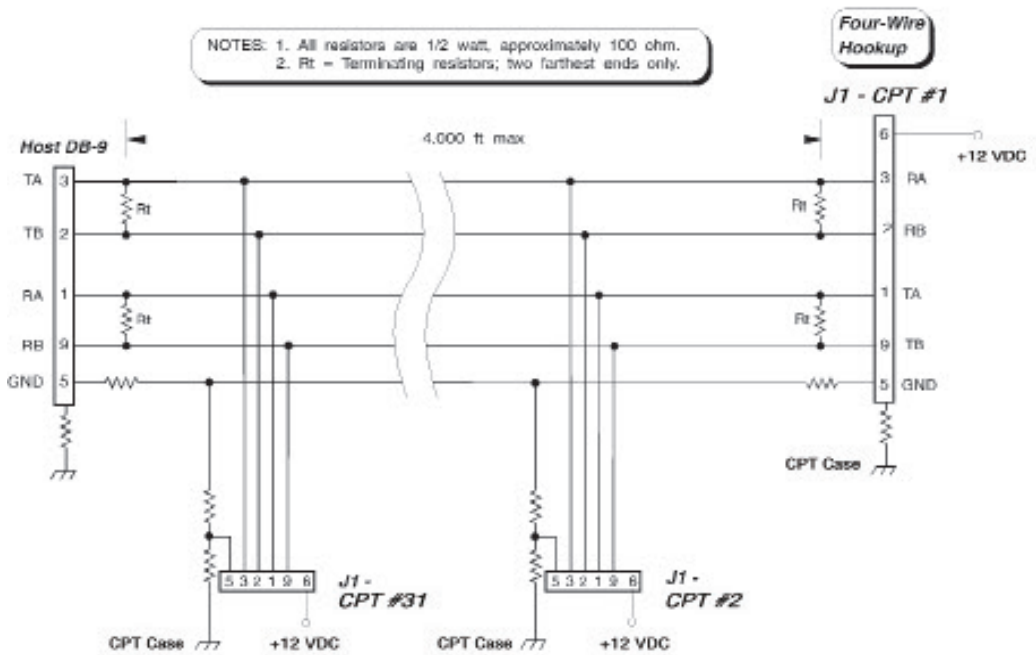

Figure 5.6.3 - RS-485 Cabling

6. Operation



Caution

Avoid excessive overpressure to the sensor! Externally mounted relief valves to provide overpressure protection are available from Mensor as optional devices, and are highly recommended for very low pressure transducers.

User programmable exponential filtering is applied to pressure readings in order to minimize at or near static pressure noise. The filter value can range from 0 (filter OFF) to 99 (maximum filtering). For any positive filter value, the filter is disabled when the pressure change between consecutive readings is greater than 0.01% full scale. However, each pressure change of 0.01% FS, or less, between consecutive readings will apply the exponential filter to the output pressure value to smooth out the readings.

The user can reset the zero and span values via the serial port in order to calibrate the instrument, or the user can change any of several other operating values. The user can also query the device for its current pressure reading, or to find the current settings for other parameters.

The serial port is set at the factory for either RS-232 or for RS-485 serial operation according to the customer's instructions. This section of the manual provides information on the serial port configuration, explains the command conventions used in this manual, and lists the common commands and queries which are recognized by the CPT61XX.

6.1 Multiple Turndown Devices

The availability of two different turndown ranges in one device has many obvious benefits, but certain issues should be noted for application of devices with multiple ranges. An important factor to remember is the two ranges are completely discrete except for the address. Consequently, certain parameters can be set to different values between the two turndown ranges.

6.1.1 Filter Effects of Multiple Turndowns

An area of concern when using devices with multiple turndowns is the effect of the exponential filter on the reading output. In the case that a user is emulating an auto-ranging scheme by quickly switching between turndown ranges of one device, the exponential filter can skew the reading output of the device immediately after a switch is made. The reason for this skewing is the persistence of previous pressure samples in the reading buffer and their use in the filtering scheme.

The filter equation for the transducer is as follows where FL is set to 90: If the change in pressure reading is less than 0.01% of the last pressure reading sampled at a 20 mS rate, then the pressure reading = (last filtered pressure * 90%) + (current sampled pressure * 10%). Otherwise the pressure reading is equal to the current sampled pressure. Default setting is 90% filtering.

Consequently, the readings from the previous active turndown in the reading buffer of the device affect the current reading. The amount the new reading is affected is a function of the size of the filter percentage setting of the active turndown. The largest offset that will be reported by the newly active turndown is 0.01% FS of the current range. In applications where readings must not slew in immediately after a turndown switch is made, it is advisable to set the filter to zero or to program a delay before the new turndown is read.

Both turndowns share the same address. However, if you change the address of one turndown without saving it, the address will revert to the previously saved address when you switch turndowns.

6.2 Serial Port Configuration

Unless otherwise requested by the customer, the CPT61XX serial ports are set at the factory to the default values listed in the following table.

Table 6.2 - Serial Port Settings

Item	Value
Type	RS-232
Address	1
Baud	9600
Data Bits	8
Parity	None
Stop Bits	1

6.3 CPT61XX Address

Each CPT61XX is assigned address “1” at the factory. In a multiple CPT61XX system each transducer must have a unique address. Valid addresses are 0 through 9 and A through Z (upper and lower case are interpreted the same). To change an address see Table 6.5.4 for command set information.

6.4 Communication Syntax and Command Conventions

All commands and responses are in ASCII characters; lower and upper case are interpreted the same. Every command or query begins with the pound symbol (#). The question mark (?) and decimal point (.) characters are significant to the CPT61XX. All other punctuation characters are ignored. Some commands require a password string. A carriage return (<cr>) or linefeed (<lf>) should terminate each command or query.

6.4.1 Wildcard Address Operator (*)

In addition to the 36 unique addresses available, an asterisk (*) functions as a wildcard address operator. However, this wildcard must not be used in queries if more than one transducer is connected to a host. The wildcard can be used to address multiple devices with commands.

One use for the wildcard address could be when a CPT61XX is pulled out of a multi-drop setup and sent to a calibration facility for recertification. The calibration technician can communicate with the device using the wildcard address without learning or changing its assigned address.

6.4.2 Password Protection

Certain commands require a password to be sent before a setting is changed. The password is only good for one command, so the password string must be sent immediately before any password protected command string. The form of the password string is described in table 6.4.4. However, for calibration protection, the actual password has been replaced with PW in the command string example. See the Password card file on the USB drive supplied with your shipment for the actual password string to be used in place of PW.

When using 2-wire RS-485 configuration, care should be taken to not append the data string with both a carriage return <cr> and a linefeed <lf>. Use one terminator or the other, only. When receiving data from the CPT61XX, both a carriage return <cr> and a linefeed <lf> will be sent to terminate the data string. The linefeed <lf> will always be the last character sent by the CPT61XX.

6.4.3 Response String Format

The CPT61XX will return an R to indicate that it has received a command or password rather than a query. When programming communication with the CPT61XX, it is advisable to look for the R response before sending additional commands or queries.

The full command word is shown in Table 6.4.4 in all capital letters. Other conventions used to describe commands are shown in Table 6.4.3.

Table 6.4.3 - Command Conventions

Convention	Description
X	Address (single character 0 through 9 or A through Z; case insensitive)
*	Wildcard address operator
?	Query operator
<sp>	Space ()
PW	Password; insert password in place of PW (see file on USB drive; case insensitive)
n	One character placeholder for digit or decimal point
n...n	Variable length field
R	Ready response
<cr>	Carriage return
<lf>	Linefeed

6.4.4 Commands and Queries



Each command that changes a parameter is volatile until the SAVE command is issued.

Notice

Table 6.4.4 - Command Set

Pass- word Protect	Command or Query	Command String	Return String	Description
No	?	#X?<cr>	X<sp>nnnnnnnnnn<cr> <lf>	Basic query to return pressure readings.
No	A	#XA<sp>n<cr>	R	Sets address of sensor to 0-9 or A-Z.
No	B?	#XB?<cr>	X<sp>B<sp>n<cr><lf>	Returns the turndown, number.
No	DC?	#XDC?<cr>	X<sp>DC<sp>nnnnnn <cr><lf>	Returns the date of calibration where nnnnnn is mmddy.
Yes	DC	#XDC<sp>nnnnn n<cr>	R	Loads the date of calibration where nnnnnn is mmddy.
No	FL?	#XFL?<cr>	X<sp>FL<sp>nn<cr> <lf>	Returns the filter – it is the percentage of old reading added to new reading: 0-99.
No	FL	#XFL<sp>nn<cr>	R	Sets the filter percentage.
No	FS?	#XFS?<cr>	X<sp>FS<sp>nnnnn<cr> <lf>	Returns the % FS accuracy.
No	ID?	#XID?<cr>	X<sp>ID<sp>nnMENSOR, <sp>nnnn61nn,<sp>nnnn nnnn<sp>Vn.nn<cr><lf>	Returns transducer ID.
N/A	PW	#XPW<cr>	R	Disables password protection for the following single command. See “6.4.2, Password Protection” for information on using the password.
No	R-?	#XR-?<cr>	X<sp>R-<sp>n...n <cr><lf>	Returns minimum range value.
No	R+?	#XR+?<cr>	X<sp>R+<sp>n...n <cr><lf>	Returns maximum range value.
No	SAVE	#XSAVE<cr>	R	Saves all data to EEPROM for the current turndown.
No	SC?	#XSC?<cr>	X<sp>SC<sp>n...n <cr><lf>	Returns a span correction multiplier.

Digital Pressure Transducer CPT6100 - CPT6180

Yes	SC	#XSC<sp>n... n<cr>	R	Loads a span correction multiplier.
No	SW	#XSW<sp>n<cr>	R	Switches between 'n'=1 for primary cal or 'n'=2 for secondary cal.
No	T?	#XT?<cr>	X<sp>T<sp>C<cr><lf>	Returns cal type.
No	U?	#XU?<cr>	X<sp>n<cr><lf>	Returns pressure unit code. See table 6.4.5.
No	ZC?	#XZC?<cr>	X<sp>ZC<sp>n...n <cr><lf>	Returns zero correction value in current units.
Yes	ZC	#XZC<sp>n... n<cr>	R	Sets zero correction value in current units.

6.4.5 Pressure Unit Code and Conversion

Table 6.4.5 - Pressure Unit Code and Conversion

Code	Unit	PSI Conversion Factor
1	psi	1
2	inHg@0°C	2.036020
3	inHg@60°F	2.041772
4	inH2O@4°C	27.68067
5	inH2O@20°C	27.72977
6	inH2O@60°F	27.70759
7	ftH2O@4°C	2.306726
8	ftH2O@20°C	2.310814
9	ftH2O@60°F	2.308966
10	mtorr (@0°C)	51715.08
11	inSW @ 0°C (3.5% salinity)	26.92334
12	ftSW @ 0°C (3.5% salinity)	2.243611
13	atm	0.06804596
14	Bars	0.06894757
15	mBars	68.94757

Digital Pressure Transducer CPT6100 - CPT6180

16	mmH ₂ O@4°C	703.0890
17	cmH ₂ O@4°C	70.30890
18	mH ₂ O@4°C	0.7030890
19	mmHg@0°C	51.71508
20	cmHg@0°C	5.171508
21	Torr	51.71508
22	Kpa	6.894757
23	Pa	6894.757
24	Dynes/cm ²	68947.57
25	g/cm ²	70.30697
26	kg/cm ²	0.07030697
27	mSW @ 0°C (3.5% salinity)	0.6838528
28	oz/in ²	16
29	psf	144
30	tsf	0.072
31	% Full Scale	
32	microns Hg @ 0°C	51715.08
33	tsi	0.0005
35	HPa	68.94757
36	MPa	0.006894757

7. Analog Output (Option)

7.1 Analog Output

The CPT6100 transducer can be configured at the time of manufacture to have voltage output that is directly proportional to the pressure input. This output is available on pins 7 (+) and 4 (-) of the DB-9 connector. The analog signal is set at the factory to one of the following ranges: 1 VDC, 5 VDC or 10 VDC.

The formula to derive the measured pressure from the output voltage is:

$$\text{pressure span} \times \text{output voltage} \div \text{voltage span} = \text{measured pressure}$$

The following example shows output voltages for two pressure values using a 0 to 250 psia full scale transducer with a 10 VDC analog signal:

Analog Output	True Pressure
0.5868 volts	14.67 psia
5.0000 volts	125.000 psia

7.1.1 Serial Commands for Analog Output

Analog output Series CPT6100 transducers respond to all of the commands listed previously in Table 6.4.4 in the Operation section. The following commands are unique to devices configured for analog output.

Table 7.1.1 - Serial Commands for Analog Output

Password Protect	Command/ Query	String	Return String	Description
No	V+?	#XV+?<cr>	X<sp>V+<sp>Y <cr><lf>	Returns voltage output upper range limit in volts d.c.
No	V-?	#XV-?<cr>	X<sp>V-<sp>Y <cr><lf>	Returns voltage output lower range limit in volts d.c.
No	VSC?	#XVSC?<cr>	X<sp>VSC<sp>Y <cr><lf>	Returns voltage output span correction multiplier.
Yes	VSC<Y>	#XVSC<sp>Y<cr>	R	Loads voltage output span correction multiplier.
No	VZC?	#XVZC?<cr>	X<sp>VZC<sp>Y Y<cr><lf>	Returns voltage output zero correction in volts.
Yes	VZC<Y>	#XVZC<sp>Y<cr>	R	Loads voltage output zero correction in volts.

7.1.2 Zero and Span Adjustment

1. Determine the current analog output correction factors:

Send: `#*PW<cr>`

Then send `#*VCZ?<cr>` and `#*VCS?<cr>`

Record these factors for longitudinal comparison of performance between calibrations.

2. Clear the current correction factors:

Send: `#*VCZ 0<cr>` and `#*VCS 1<cr>`

3. Connect a DMM to the analog output pins of the transducer (pin 7 is +, pin 4 is (-). Apply a known true pressure at or near zero and take a reading with the DMM. Calculate the equivalent analog output voltage for the applied pressure using the formula:

$$\text{pressure span} \times \text{output voltage} \div \text{voltage span} = \text{measured pressure}$$

Subtract this value from the DMM reading. Send the resulting offset value to the transducer with the VCZ command.

4. Apply a known true pressure at or near the full scale pressure of the transducer. Take a reading with the DMM. Calculate the equivalent analog output voltage for the applied pressure using the formula:

$$\text{true pressure} \div \text{full scale value} \times \text{analog full scale value}$$

Divide the calculated value by the reading of the DMM. The resulting value is the span correction factor and should be loaded into the transducer using the VCS command.

5. Send a SAVE command to the transducer to move the correction factors to non-volatile memory.

7.1.3 Specifications

Resolution:	0-1 VDC	1 part per 80,000 minimum
	0-5 VDC	1 part per 400,000 minimum
	0-10 VDC	1 part per 800,000 minimum

Update Rate: 50Hz

Uncertainties:	0-1 VDC	0.010% FS
	0-5 VDC	0.010% FS
	0-10 VDC	0.010% FS

Minimum input impedance of the device measuring the analog output is 1 Megaohm.

8. Calibration

The CPT61XX transducer automatically adjusts the pressure readings for the effects of temperature and non-linearity within the calibrated temperature range of 15-45°C. Thus, a calibrated CPT61XX operated within its temperature band, and with proper zero and span settings, will provide accurate pressure measurements.

The transducer should have the span verified periodically to insure its stability. Initially, the recommended period between calibrations is as specified. This period may be extended as confidence is gained in the span stability.

8.1 Environment

Whenever possible, calibrate the CPT61XX at the same ambient temperature as its normal operating environment. The temperature should be stable, and within the specified calibration range. In addition, for maximum accuracy, see that the CPT61XX is at rest on a stable platform which is free of vibration and shock, and oriented similar to its final installation attitude. At the factory the CPT61XX is calibrated vertically with the pressure port at the top.

8.2 Equipment

The following equipment is needed to calibrate a gauge transducer (see Figure 8.2):

1. A downloadable version of the most recent calibration utility program. Go to <http://www.mensor.com>, click "Download", click "Software", click "PC software", then click on Operating & Calibration software for the series CPT6xxx digital pressure transducers. The calibration utility program is also available on CD by request.
2. A host computer with a serial port to match the CPT61XX (RS-232 or RS-485), software to run the CPT61XX transducer, and an appropriate cable.
3. Appropriate pressure and vacuum sources and calibration reference standards for the CPT61XX's pressure range
4. Tubing, fittings and valves adequate for the pressure range.
5. To calibrate the optional analog output signal a high accuracy digital multi-meter is required. Refer to "7.1.1 - Analog Output Option" for zero and span adjustment information.

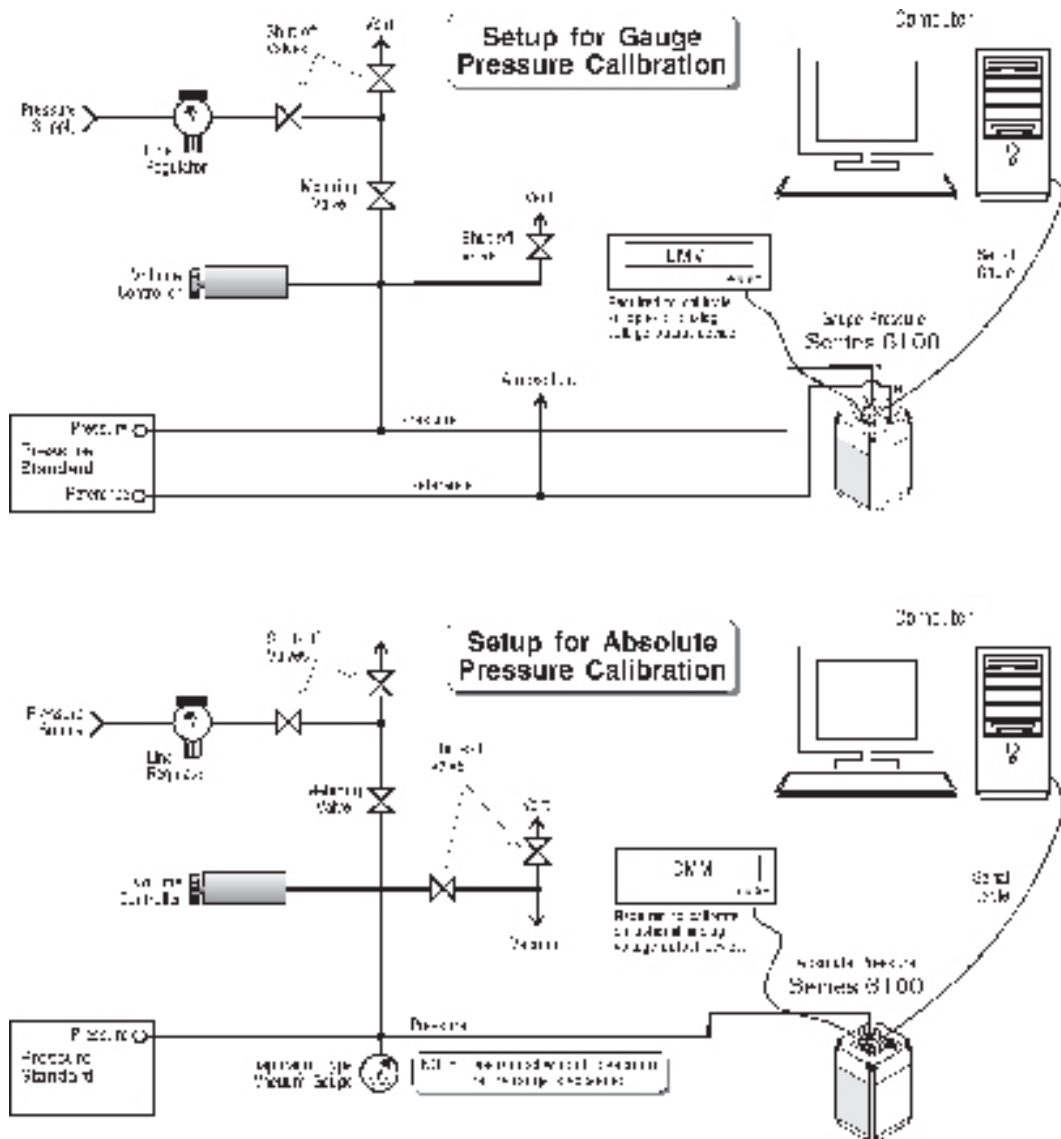

Figure 8.2 - Calibration Setup

8.3 Pressure Standard

Mensor recommends the use of appropriately accurate primary pressure standards when calibrating this instrument. Such standards should be sufficient so that when the techniques of the ISO Guide to the Expression of Uncertainty in Measurement (GUM) are applied, the instrument meets its accuracy statements as required by ANSI/NC SL Z540, or other applicable standards. The same requirement applies to the vacuum gauge used to set the zero offset on absolute calibrations. The recommended pressure for setting the zero offset on absolute transducers is between 600 mTorr absolute and 20% of the active transducer's span.

8.4 Calibration Medium

The recommended calibration medium for sensors up to 6000 psi is dry nitrogen or clean, dry instrument air. Hydraulic media (water or oil for example) are recommended for ranges above this. Hydraulic media can be used with lower ranges, however, special techniques must be used in filling the connection lines and transducer.

8.5 Calibration Process

Please notice that the commands listed in this section are shown in the same style as those in the Operation section. These are the bare commands seen by the CPT61XX, stripped of all programming idioms. Depending on the specific language used to generate them, these commands may have to be preceded by or enclosed in various symbols for transmission. For this procedure it is assumed that a single CPT61XX is connected to the host computer, and that its assigned address is unknown.

The model, serial number, and software version number of the CPT61XX being calibrated can be obtained by sending: `#*ID?<cr>`.

8.6 Correction Value Query

The stored correction for zero offset or the span correction factor can be retrieved over the bus. The returned values have six significant digits plus a decimal point and a sign. To see the stored values send either:

`#*ZC?<cr>` or `#*SC?<cr>`

These commands may be useful in determining the actual changes in zero and span over time. Unauthorized alterations of the values can be detected by comparison with previously recorded correction values.



Notice

Each command issued to either calibration parameter must be followed by the SAVE command to make it permanent. Otherwise, the changes will be lost the next time the CPT61XX loses power.

8.7 Zero Adjustment

To adjust zero, first determine the correct zero offset, then send the password, and then send the new zero value. Applying the correct zero pressure and finding the resulting zero offset is different for an absolute transducer than it is for a gauge type unit. Once the zero offset is known, the procedure for sending the zero correction value (which sets the output to zero) is the same for either type of transducer. When the zero offset is correct, issue a SAVE command to preserve it in non-volatile memory.

8.7.1 Gauge Zero Offset

Substitute the required password in place of “PW” in the following examples:

1. Determine the current zero offset and make a note of the returned reading.
Next send: `#*ZC?<cr>`
Record the date and this reading to track zero changes between calibrations.
2. Vent the PRESSURE and REFERENCE ports to atmosphere.
The true pressure is now 0 (zero).
Send: `#*PW<cr>`
Next send: `#*ZC<sp>0<cr>`
This will clear the current zero offset from RAM.
3. While vented, determine the current zero pressure reading of the CPT61XX.
Send: `#*?<cr>`
Make a note of the zero value returned by the CPT61XX.
4. Subtract the current zero reading from true zero.
The difference is the new zero offset.

Example: For a 0-30 psi unit with both ports vented:

True Pressure = 0 (vented)

Current Pressure reading (from step 4) = +0.0023 psi

True Pressure – Current Pressure = New Offset

0.0000 (–) +0.0023 = –0.0023 psi offset

5. Enter the new offset into memory.
Send: `#*PW<cr>`
Next send the zero offset: `#*ZC<sp>-.0023<cr>`
The new offset of –0.0023 will now be added to all pressure readings of the CPT61XX.
Send: `#*SAVE<cr>` to store the new value in non-volatile memory.
6. To check the zero correction:
Send: `#*?<cr>`
The reading returned should be 0.0000 psi with both ports vented.

8.7.2 Absolute Zero Offset

Substitute the required password in place of “PW” in the following examples:

1. Find the current zero offset and make a note of the returned value.
Send: `#*ZC?
<cr>` and record the reading.
2. Use the setup for absolute pressure shown in Figure 8.2. Apply a stable pressure value between 600 mTorr absolute and 20% of the transducer’s span. Measure the reference pressure reading in the native units of the CPT61XX. This reading becomes the “true pressure”.
3. Clear the current zero offset from RAM.
Send: `#*PW
<cr>`
Next send: `#*ZC 0
<cr>`
4. Determine the current pressure reading.
Send: `#*?
<cr>` and make a note of this reading.
5. Subtract the current pressure reading from the true pressure reading.
The difference is the zero offset now required.

Example: For a 0-15 psia unit with 600 millitorr absolute pressure applied, using psi units:

600 millitorr = 0.0116 psia (True Pressure)

Current Pressure reading (from step 4) = -0.0011 psia

True Pressure – Current Pressure = New Offset

0.0116 (-) -0.0011 = +0.01059 psi offset

6. Enter the new offset into memory.
Send: `#*PW
<cr>`
Then send: `#*ZC
<sp>.0105
<cr>`
The new offset of 0.0105 will now be added to all pressure readings.
Send: `#*SAVE
<cr>` to store the new value in non-volatile memory.
7. To check the zero correction:
Send: `#*?
<cr>`
For 600 mtorr the pressure reading returned should be 0.0116 psia.

8.8 Span Adjustment

The span adjustment procedure is the same for gauge and absolute units. Always make zero corrections before changing the span factor. A scale factor within the range of 0.9 to 1.1 is used as a multiplier to correct for span shifts.

1. Determine the current span scale factor and record the reading.

Send: `#*SC?<cr>`

This reading can be used at some later date to detect a span change between calibrations.

2. To clear the current scale factor:

Send: `#*PW<cr>`

Next send: `#*SC<sp>1<cr>`

3. Apply a known true pressure equal to the span of the CPT61XX.

To determine the CPT61XX pressure reading:

Send: `#*?<cr>` and make a note of this reading.

4. Divide the known true pressure by the CPT61XX pressure reading.

The result is the required new span scale factor.

Example: For a 150 psi unit:

True pressure = 150.003 psi

CPT61XX pressure reading (from step 3) = 149.984 psi

True pressure/CPT61XX pressure = New Span Scale Factor

$150.003/149.984 = 1.000127$

5. To enter the new span scale factor:

Send: `#*PW<cr>`

Then send: `#*SC<sp>1.000127<cr>`

Send: `#*SAVE<cr>` to store the new value in non-volatile memory.

All future pressure readings returned by this CPT61XX will be multiplied by a scale factor of 1.000127 before they are transmitted over the bus.

6. To check the span reading:

Send: `#*?<cr>`

The returned pressure value should be 150.003 psi, if the pressure has not changed.

9. Accessories

9.1 Fittings & Gaskets

Mensor supplies a customer specified fitting with each transducer. Available fittings to connect to the transducer have the following Mensor Part numbers:

Part Number	Description
6000604023	1/4 in. FNPT,
6000604024	1/8 in. FBSPG
6000604025	6 mm tube
4250040006	1/4 in. tube

Many other fittings are available, consult the factory if you need assistance.

9.2 Accessories

Part Number	Description
8200100013	Carrying case
0017245002	Power adaptor with communication
4060200005	USB to 232 converter
0018846001	USB to 485 converter
	Relief valves
Call to inquire	Customizable external overpressure protection

Notes



Mensor Corporation

201 Barnes Drive
San Marcos, TX 78666 • USA
Tel. (+1) 512 3964200-15
Fax (+1) 512 3961820
E-Mail sales@mensor.com
www.mensor.com



**WIKA Alexander Wiegand SE
& Co. KG**

Alexander-Wiegand-Straße 30
63911 Klingenberg • Germany
Tel. +49 9372 132-0
Fax +49 9372 132-406
info@wika.de

Imported to UK by:

WIKA Instruments Ltd,
Unit 6 & 7 Goya Business Park,
The Moor Road, Sevenoaks
Kent, TN15 5GY