

# Operating Instructions

## Process pressure transmitter CPT-2x

GB

Profibus PA  
Ceramic measuring cell



Process pressure transmitter CPT-2x



## Contents

<b>1</b>	<b>About this document</b> .....	<b>4</b>
1.1	Function .....	4
1.2	Target group .....	4
1.3	Symbols used .....	4
<b>2</b>	<b>For your safety</b> .....	<b>5</b>
2.1	Authorised personnel .....	5
2.2	Appropriate use .....	5
2.3	Warning about incorrect use .....	5
2.4	General safety instructions .....	5
2.5	Conformity .....	5
2.6	NAMUR recommendations .....	6
2.7	Installation and operation in the USA and Canada .....	6
<b>3</b>	<b>Product description</b> .....	<b>7</b>
3.1	Configuration .....	7
3.2	Principle of operation .....	7
3.3	Supplementary cleaning procedures .....	11
3.4	Packaging, transport and storage .....	12
<b>4</b>	<b>Mounting</b> .....	<b>13</b>
4.1	General instructions .....	13
4.2	Instructions for oxygen applications .....	15
4.3	Ventilation and pressure compensation .....	15
4.4	Process pressure measurement .....	17
4.5	Level measurement .....	19
4.6	External housing .....	19
<b>5</b>	<b>Connecting to the bus system</b> .....	<b>20</b>
5.1	Preparing the connection .....	20
5.2	Connecting .....	21
5.3	Single chamber housing .....	22
5.4	Double chamber housing .....	22
5.5	Housing IP66/IP68 (1 bar) .....	23
5.6	External housing with version IP68 (25 bar) .....	24
5.7	Switch-on phase .....	25
<b>6</b>	<b>Set up with the display and adjustment module</b> .....	<b>27</b>
6.1	Insert display and adjustment module .....	27
6.2	Adjustment system .....	28
6.3	Measured value indication .....	29
6.4	Parameter adjustment - Quick setup .....	30
6.5	Parameter adjustment - Extended adjustment .....	30
6.6	Save parameter adjustment data .....	41
<b>7</b>	<b>Diagnosis, asset management and service</b> .....	<b>43</b>
7.1	Maintenance .....	43
7.2	Cleaning - hygienic connection with compression nut .....	43
7.3	Diagnosis memory .....	44
7.4	Asset Management function .....	45
7.5	Rectify faults .....	48
7.6	Exchange process module on version IP68 (25 bar) .....	48
7.7	Instrument repair .....	49

<b>8</b>	<b>Dismount.....</b>	<b>50</b>
8.1	Dismounting steps.....	50
8.2	Disposal .....	50
<b>9</b>	<b>Supplement .....</b>	<b>51</b>
9.1	Technical data .....	51
9.2	Communication Profibus PA.....	64
9.3	Calculation of the total deviation.....	68
9.4	Calculation of the total deviation - Practical example.....	68
9.5	Dimensions .....	71
9.6	Trademark .....	81

**Safety instructions for Ex areas:**



Take note of the Ex specific safety instructions for Ex applications. These instructions are attached as documents to each instrument with Ex approval and are part of the operating instructions.

Editing status: 2023-09-01

# 1 About this document

## 1.1 Function

This instruction provides all the information you need for mounting, connection and setup as well as important instructions for maintenance, fault rectification, safety and the exchange of parts. Please read this information before putting the instrument into operation and keep this manual accessible in the immediate vicinity of the device.

## 1.2 Target group

This operating instructions manual is directed to trained personnel. The contents of this manual must be made available to the qualified personnel and implemented.

## 1.3 Symbols used



**Information, note, tip:** This symbol indicates helpful additional information and tips for successful work.



**Note:** This symbol indicates notes to prevent failures, malfunctions, damage to devices or plants.



**Caution:** Non-observance of the information marked with this symbol may result in personal injury.



**Warning:** Non-observance of the information marked with this symbol may result in serious or fatal personal injury.



**Danger:** Non-observance of the information marked with this symbol results in serious or fatal personal injury.



### Ex applications

This symbol indicates special instructions for Ex applications.



### List

The dot set in front indicates a list with no implied sequence.



### Sequence of actions

Numbers set in front indicate successive steps in a procedure.



### Disposal

This symbol indicates special instructions for disposal.

## 2 For your safety

### 2.1 Authorised personnel

All operations described in this documentation must be carried out only by trained and authorized personnel.

During work on and with the device, the required personal protective equipment must always be worn.

### 2.2 Appropriate use

The CPT-2x is a pressure transmitter for process pressure and hydrostatic level measurement.

You can find detailed information about the area of application in chapter " *Product description*".

Operational reliability is ensured only if the instrument is properly used according to the specifications in the operating instructions manual as well as possible supplementary instructions.

### 2.3 Warning about incorrect use

Inappropriate or incorrect use of this product can give rise to application-specific hazards, e.g. vessel overfill through incorrect mounting or adjustment. Damage to property and persons or environmental contamination can result. Also, the protective characteristics of the instrument can be impaired.

### 2.4 General safety instructions

This is a state-of-the-art instrument complying with all prevailing regulations and directives. The instrument must only be operated in a technically flawless and reliable condition. The operating company is responsible for the trouble-free operation of the instrument. When measuring aggressive or corrosive media that can cause a dangerous situation if the instrument malfunctions, the operating company has to implement suitable measures to make sure the instrument is functioning properly.

The safety instructions in this operating instructions manual, the national installation standards as well as the valid safety regulations and accident prevention rules must be observed.

For safety and warranty reasons, any invasive work on the device beyond that described in the operating instructions manual may be carried out only by personnel authorised by us. Arbitrary conversions or modifications are explicitly forbidden. For safety reasons, only the accessory specified by us must be used.

To avoid any danger, the safety approval markings and safety tips on the device must also be observed.

### 2.5 Conformity

The device complies with the legal requirements of the applicable country-specific directives or technical regulations. We confirm conformity with the corresponding labelling.

The corresponding conformity declarations can be found on our homepage.

Due to the design of its process fittings, the device does not subject of EU pressure device directive if it is operated at process pressures  $\leq 200$  bar.

### **2.6 NAMUR recommendations**

NAMUR is the automation technology user association in the process industry in Germany. The published NAMUR recommendations are accepted as the standard in field instrumentation.

The device fulfils the requirements of the following NAMUR recommendations:

- NE 21 – Electromagnetic compatibility of equipment
- NE 53 – Compatibility of field devices and display/adjustment components
- NE 107 – Self-monitoring and diagnosis of field devices

For further information see [www.namur.de](http://www.namur.de).

### **2.7 Installation and operation in the USA and Canada**

This information is only valid for USA and Canada. Hence the following text is only available in the English language.

Installations in the US shall comply with the relevant requirements of the National Electrical Code (NEC - NFPA 70) (USA).

Installations in Canada shall comply with the relevant requirements of the Canadian Electrical Code (CEC Part) (Canada).

## 3 Product description

### 3.1 Configuration

#### Scope of delivery

The scope of delivery encompasses:

- Instrument CPT-2x

The further scope of delivery encompasses:

- Documentation
  - Quick setup guide CPT-2x
  - Test certificate for pressure transmitters
  - Instructions for optional instrument features
  - Ex-specific "*Safety instructions*" (with Ex versions)
  - If necessary, further certificates



#### Information:

Optional instrument features are also described in this operating instructions manual. The respective scope of delivery results from the order specification.

#### Type label

The type label contains the most important data for identification and use of the instrument:

- Instrument type
- Information about approvals
- Configuration information
- Technical data
- Serial number of the instrument
- QR code for device identification
- Manufacturer information

#### Documents and software

Further information can be found on our homepage.

There you will find the documentation and further information about the device.

### 3.2 Principle of operation

#### Application area

CPT-2x is suitable for applications in virtually all industries. It is used for the measurement of the following pressure types.

- Gauge pressure
- Absolute pressure
- Vacuum

#### Measured products

Measured products are gases, vapours and liquids.

Depending on the process fitting and measurement setup, measured products can be also viscous or contain abrasive substances.

#### Measured variables

The CPT-2x is suitable for the measurement of the following process variables:

- Process pressure
- Level

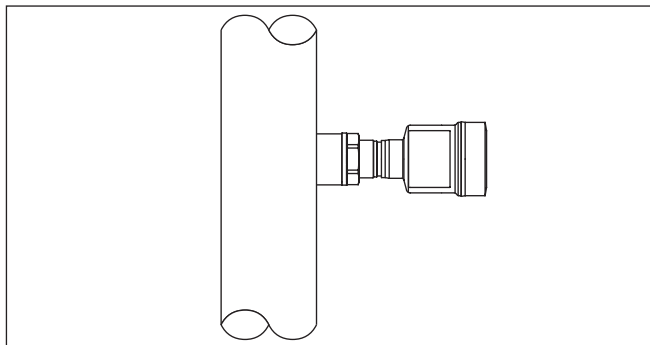

Fig. 1: Process pressure measurement CPT-2x

#### Measuring system pressure

Sensor element is the measuring cell with robust ceramic diaphragm. The process pressure deflects the ceramic diaphragm and causes a capacitance change in the measuring cell. This capacitance change is converted into an electrical signal and output as measured value via the output signal.

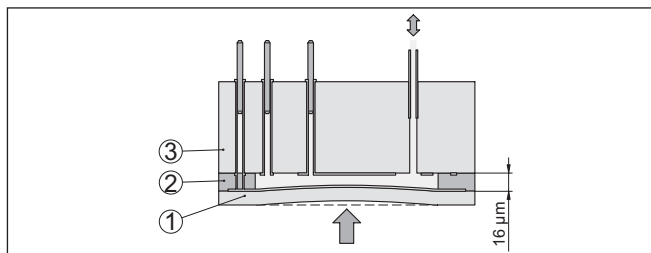

Fig. 2: Configuration of the ceramic measuring cell

- 1 Process diaphragm
- 2 Glass joint
- 3 Base element

The measuring cell is available in two sizes:  $\varnothing$  28 mm and  $\varnothing$  17.5 mm.

#### Measuring system temperature

Temperature sensors in the ceramic diaphragm and on the ceramic body of the  $\varnothing$  28 mm measuring cell or on the electronics of the  $\varnothing$  17.5 mm measuring cell detect the current process temperature. The temperature value is output via:

- The display and adjustment module
- The current output or the digital signal output

Even extreme jumps in process temperature are immediately detected by the  $\varnothing$  28 mm measuring cell. The values in the ceramic diaphragm are compared with those on the ceramic base body. Within a few measuring cycles, the intelligent sensor electronics compensates for otherwise unavoidable measurement deviations caused by temperature shocks in the range. Depending on the adjusted damping, these cause only slight and brief changes in the output signal.



#### Pressure types

The measuring cell design depends on the selected pressure type.

**Relative pressure:** the measuring cell is open to the atmosphere. The ambient pressure is detected in the measuring cell and compensated. It thus has no influence on the measured value.

**Absolute pressure:** the measuring cell contains vacuum and is encapsulated. The ambient pressure is not compensated and does hence influence the measured value.

#### Seal concepts

The following presentations show examples for the installation of the ceramic measuring cell into the process fitting and the different seal concepts.

#### Recessed installation

The recessed installation is particularly suitable for applications with gases, vapours and clear liquids. The measuring cell seal is positioned laterally as well as in addition in front.

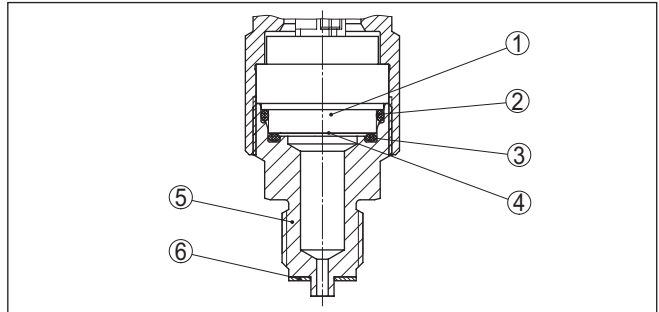

Fig. 3: Recessed installation of the measuring cell (example: manometer connection G $\frac{1}{2}$ )

- 1 Measuring cell
- 2 Seal for the measuring cell
- 3 Additional, front seal for measuring cell
- 4 Diaphragm
- 5 Process fitting
- 6 Seal for the process fitting

#### Front-flush mounting with single seal

The front-flush installation is particularly suitable for applications with viscous and abrasive media and in case of buildup. The measuring cell seal is positioned laterally.

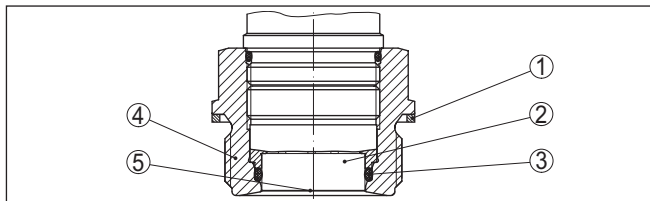

Fig. 4: Front-flush installation of the measuring cell (example: thread G1½)

- 1 Seal for the process fitting
- 2 Measuring cell
- 3 Seal for the measuring cell
- 4 Process fitting
- 5 Diaphragm

### Completely front-flush mounting with single seal

The completely front-flush mounting is particularly suitable for applications in the paper industry. The diaphragm is in the pulp flow, is hence cleaned and protected against buildup.

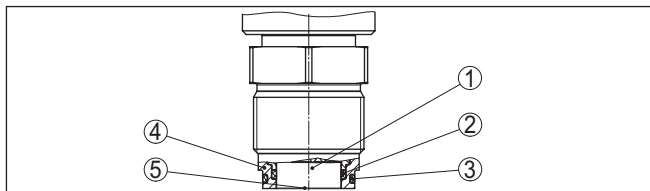

Fig. 5: Front-flush installation of the measuring cell (example: M30 x 1.5)

- 1 Measuring cell
- 2 Seal for the measuring cell
- 3 Seal for the process fitting
- 4 Process fitting
- 5 Diaphragm

### Front-flush mounting with double seal

The front-flush installation is particularly suitable for applications with viscous media. The additional, front sealing protects the glass joint of the measuring cell against chemical attack and the measuring cell electronics against diffusion of aggressive gases from the process.

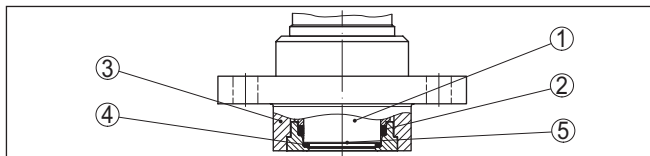

Fig. 6: Front-flush installation of the measuring cell with double seal (example: flange connection with extension)

- 1 Measuring cell
- 2 Seal for the measuring cell
- 3 Process fitting
- 4 Additional, front seal for measuring cell
- 5 Diaphragm

#### Installation in hygienic fitting

The front-flush, hygienic installation of the measuring cell is particularly suitable for food applications. The sealings are installed gap-free. The form seal of the measuring cell protects also the glass joint.

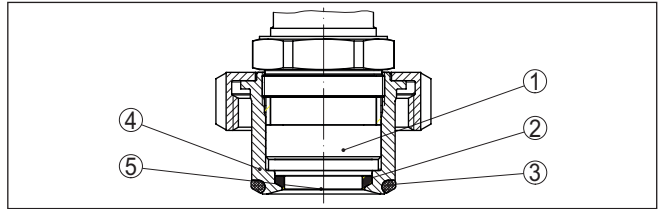

Fig. 7: Hygienic installation of the measuring cell (example: hygienic fitting with compression nut)

- 1 Measuring cell
- 2 Form seal for the measuring cell
- 3 Gap-free seal for process fitting
- 4 Process fitting
- 5 Diaphragm

#### Installation in hygienic fitting acc. to 3-A

The front-flush, hygienic installation of the measuring cell acc. to 3-A is particularly suitable for food applications. The sealings are installed gap-free. The additional front sealing for the measuring cell protects also the glass joint. A hole in the process fitting is used for leakage detection.

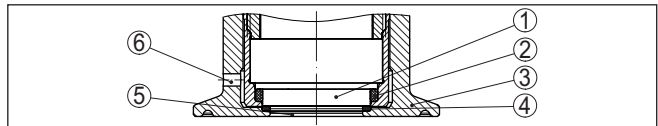

Fig. 8: Hygienic installation of the measuring cell acc. to 3-A (example: Clamp connection)

- 1 Measuring cell
- 2 Seal for the measuring cell
- 3 Process fitting
- 4 Additional, front seal for measuring cell
- 5 Diaphragm
- 6 Hole for leakage detection

### 3.3 Supplementary cleaning procedures

The CPT-2x is also available in the version "Oil, grease and silicone-free" or cleaning for paint compatible version (LABS). These instruments have passed through a special cleaning procedure to remove oil, grease and paint-wetting impairment substances (PWIS).

The cleaning is carried out on all wetted parts as well as on surfaces accessible from outside. To keep the purity level, the instruments are immediately packed in plastic foil after the cleaning process. The purity level remains as long as the instrument is kept in the closed original packaging.

**Caution:**

The CPT-2x in these versions must not be used in oxygen applications. For this purpose, devices in the special version "*Resistance to Internal Ignition in oxygen operation according to BAM certification*" are available.

### 3.4 Packaging, transport and storage

**Packaging**

Your instrument was protected by packaging during transport. Its capacity to handle normal loads during transport is assured by a test based on ISO 4180.

The packaging consists of environment-friendly, recyclable cardboard. For special versions, PE foam or PE foil is also used. Dispose of the packaging material via specialised recycling companies.

**Transport**

Transport must be carried out in due consideration of the notes on the transport packaging. Nonobservance of these instructions can cause damage to the device.

**Transport inspection**

The delivery must be checked for completeness and possible transit damage immediately at receipt. Ascertained transit damage or concealed defects must be appropriately dealt with.

**Storage**

Up to the time of installation, the packages must be left closed and stored according to the orientation and storage markings on the outside.

Unless otherwise indicated, the packages must be stored only under the following conditions:

- Not in the open
- Dry and dust free
- Not exposed to corrosive media
- Protected against solar radiation
- Avoiding mechanical shock and vibration

**Storage and transport temperature**

- Storage and transport temperature see chapter "*Supplement - Technical data - Ambient conditions*"
- Relative moisture 20 ... 85 %

**Lifting and carrying**

With instrument weights of more than 18 kg (39.68 lbs) suitable and approved equipment must be used for lifting and carrying.

## 4 Mounting

### 4.1 General instructions

#### Process conditions



**Note:**

For safety reasons, the instrument must only be operated within the permissible process conditions. You can find detailed information on the process conditions in chapter " *Technical data*" of the operating instructions or on the type label.

Hence make sure before mounting that all parts of the instrument exposed to the process are suitable for the existing process conditions.

These are mainly:

- Active measuring component
- Process fitting
- Process seal

Process conditions in particular are:

- Process pressure
- Process temperature
- Chemical properties of the medium
- Abrasion and mechanical influences

#### Protection against moisture

Protect your instrument against moisture ingress through the following measures:

- Use a suitable connection cable (see chapter " *Connecting to power supply*")
- Tighten the cable gland or plug connector
- Lead the connection cable downward in front of the cable entry or plug connector

This applies mainly to outdoor installations, in areas where high humidity is expected (e.g. through cleaning processes) and on cooled or heated vessels.



**Note:**

Make sure that during installation or maintenance no moisture or dirt can get inside the instrument.

To maintain the housing protection, make sure that the housing lid is closed during operation and locked, if necessary.

#### Screwing in

Devices with threaded fitting are screwed into the process fitting with a suitable wrench via the hexagon.

See chapter " *Dimensions*" for wrench size.



**Warning:**

The housing or the electrical connection may not be used for screwing in! Depending on the device version, tightening can cause damage, e. g. to the rotation mechanism of the housing.

#### Vibrations

Avoid damages on the device by lateral forces, for example by vibrations. It is thus recommended to fix the devices with process fitting

thread G $\frac{1}{2}$  of plastic at the installation site via a suitable measuring instrument holder.

If there is strong vibration at the mounting location, the instrument version with external housing should be used. See chapter " *External housing*".

### Permissible process pressure (MWP) - Device

The permissible process pressure range is specified by "MWP" (Maximum Working Pressure) on the type label, see chapter " *Structure*". The MWP takes the element of the measuring cell and processing fitting combination with the weakest pressure into consideration and may applied permanently. The specification refers to a reference temperature of +20 °C (+68 °F). It also applies when a measuring cell with a higher measuring range than the permissible pressure range of the process fitting is installed order-related.

In addition, a temperature derating of the process fitting, e. g. with flanges, can limit the permissible process pressure range according to the respective standard.



#### Note:

In order to prevent damage to the device, a test pressure may only exceed the specified MWP briefly by 1.5 times at reference temperature. The pressure stage of the process fitting as well as the overload resistance of the measuring cell are taken into consideration here (see chapter " *Technical Data*").

### Permissible process pressure (MWP) - Mounting accessory

The permissible process pressure range is stated on the type label. The instrument should only be operated with these pressures if the mounting accessory used also fulfils these values. This should be ensured by suitable flanges, welded sockets, tension rings with Clamp connections, sealings, etc.

### Temperature limits

Higher process temperatures often mean also higher ambient temperatures. Make sure that the upper temperature limits stated in chapter " *Technical data*" for the environment of the electronics housing and connection cable are not exceeded.

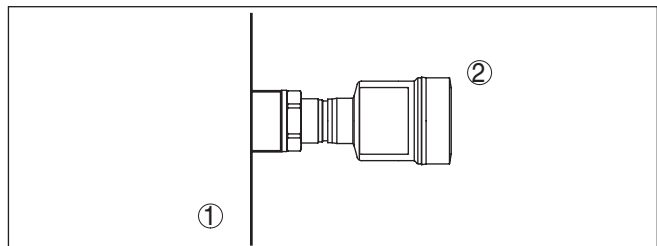

Fig. 9: Temperature ranges

- 1 Process temperature
- 2 Ambient temperature

## 4.2 Instructions for oxygen applications



### Warning:

As an oxidising agent, oxygen can cause or intensify fires. Oils, grease, some plastics and dirt can burn explosively on contact with oxygen. There is a risk of serious personal injury or damage to property.

Therefore, to avoid this, take the following precautions, for example:

- All components of the system - measuring instruments - must be cleaned in accordance with the requirements of recognized regulations or standards
- Depending on the seal material, certain temperatures and pressures must not be exceeded in oxygen applications, see chapter "Technical data"
- Devices for oxygen applications may only be unpacked from the PE foil just before assembly.
- Check whether the marking "O2" is visible on the process fitting after removing the protection for the process fitting
- Avoid any ingress of oil, grease and dirt

## 4.3 Ventilation and pressure compensation

### Filter element - Position

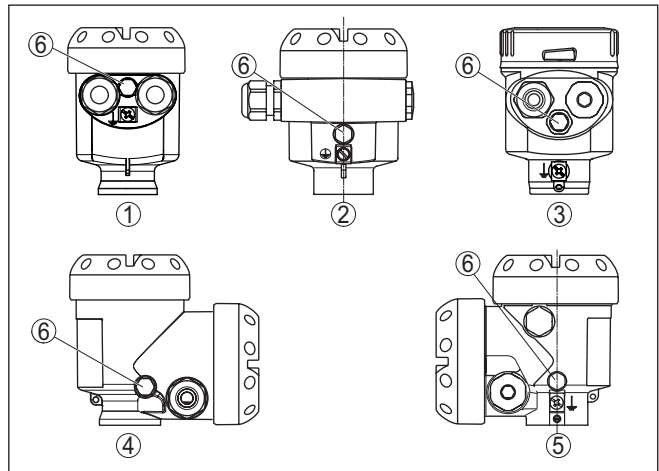

Fig. 10: Position of the filter element

- 1 Plastic, stainless steel single chamber (precision casting)
- 2 Aluminium - single chamber
- 3 Stainless steel single chamber (electropolished)
- 4 Plastic double chamber
- 5 Aluminium - double chamber
- 6 Filter element

With the following instruments a blind plug is installed instead of the filter element:

- Instruments in protection IP66/IP68 (1 bar) - ventilation via capillaries in non-detachable cable
- Instruments with absolute pressure

**Filter element - Position Ex d version**

→ Turn the metal ring in such a way that the filter element points downward after installation of the instrument. This provides better protection against buildup.

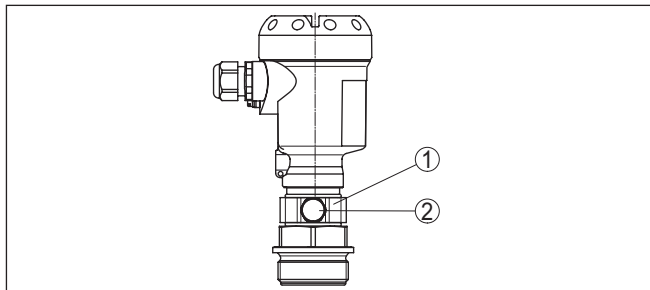

Fig. 11: Position of the filter element - Ex d version

- 1 Rotatable metal ring
- 2 Filter element

Instruments with absolute pressure have a blind plug mounted instead of the filter element.

**Filter element - Position Second Line of Defense**

The Second Line of Defense (SLOD) is a second level of the process separation in form of a gas-tight leadthrough in the housing neck, preventing products from penetrating into the housing.

With these instruments, the process assembly is completely encapsulated. An absolute pressure measuring cell is used so that no ventilation is required.

With relative pressure measuring ranges, the ambient pressure is detected and compensated by a reference sensor in the electronics.

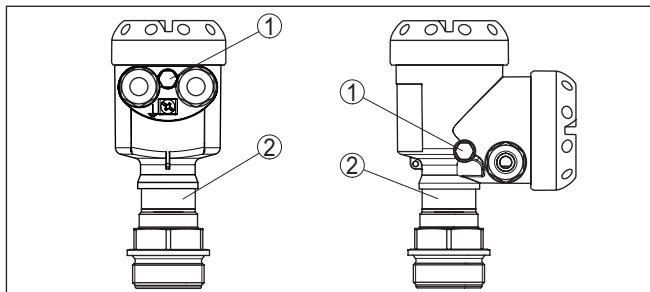

Fig. 12: Position of the filter element - gastight leadthrough

- 1 Filter element
- 2 Gas-tight leadthrough



**Filter element - Position  
IP69K version**

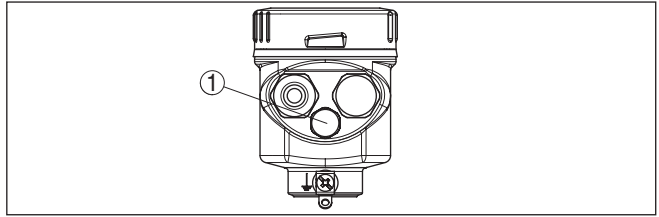

Fig. 13: Position of the filter element - IP69K version

1 Filter element

Instruments with absolute pressure have a blind plug mounted instead of the filter element.

**4.4 Process pressure measurement**

Keep the following in mind when setting up the measuring system:

- Mount the instrument above the measuring point

Possible condensation can then drain off into the process line.

**Measurement setup in  
gases**

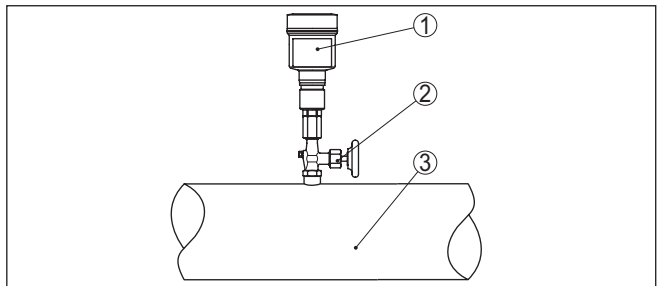

Fig. 14: Measurement setup for process pressure measurement of gases in pipelines

1 CPT-2x  
2 Blocking valve  
3 Pipeline

**Measurement setup in  
vapours**

Keep the following in mind when setting up the measuring system:

- Connect via a siphon
- Do not insulate the siphon
- Fill the siphon with water before setup

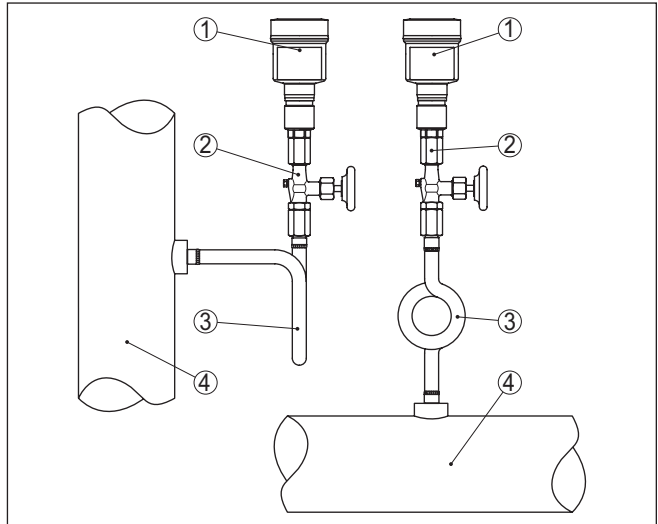

Fig. 15: Measurement setup for process pressure measurement of gases in pipelines

- 1 CPT-2x
- 2 Blocking valve
- 3 Siphon in U or circular form
- 4 Pipeline

A protective accumulation of water is formed through condensation in the pipe bends. Even in applications with hot steam, a medium temperature  $< 100\text{ °C}$  on the transmitter is ensured.

### Measurement setup in liquids

Keep the following in mind when setting up the measuring system:

- Mount the instrument below the measuring point

The effective pressure line is always filled with liquid and gas bubbles can bubble up to the process line.

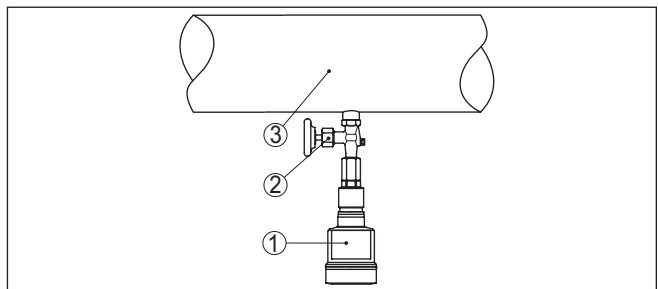

Fig. 16: Measurement setup for process pressure measurement of liquids in pipelines

- 1 CPT-2x
- 2 Blocking valve
- 3 Pipeline

## 4.5 Level measurement

### Measurement setup

Keep the following in mind when setting up the measuring system:

- Mount the instrument below the min. level
- Do not mount the instrument close to the filling stream or emptying area
- Mount the instrument so that it is protected against pressure shocks from the stirrer

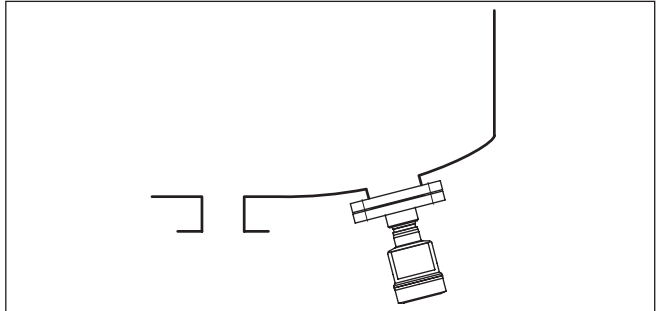

Fig. 17: Measurement setup for level measurement

## 4.6 External housing

### Configuration

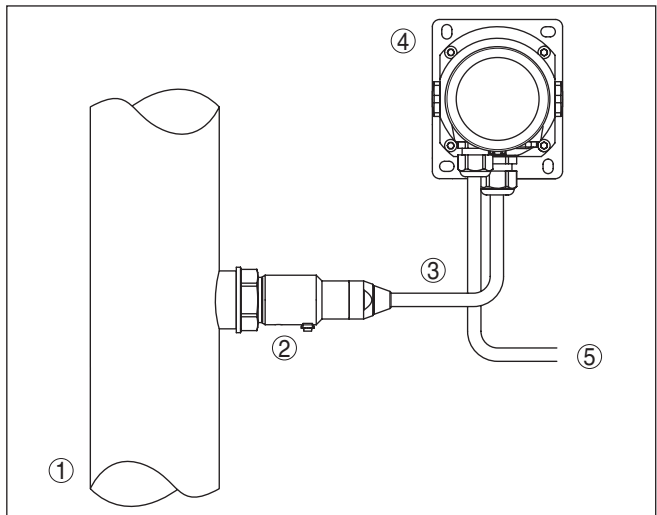

Fig. 18: Configuration, process module, external housing

- 1 Pipeline
- 2 Process module
- 3 Connection cable process assembly - External housing
- 4 External housing
- 5 Signal cable

## 5 Connecting to the bus system

### 5.1 Preparing the connection

#### Safety instructions

Always keep in mind the following safety instructions:

- Carry out electrical connection by trained, qualified personnel authorised by the plant operator
- If overvoltage surges are expected, overvoltage arresters should be installed



#### Warning:

Only connect or disconnect in de-energized state.

#### Voltage supply

The voltage supply is provided by a Profibus DP /PA segment coupler. The voltage supply range can differ depending on the instrument version. You can find the data for voltage supply in chapter " *Technical data*".

#### Connection cable

Connection is made with shielded cable according to the Profibus specification. Power supply and digital bus signal are carried over the same two-wire connection cable.

Use cable with round cross section for instruments with housing and cable gland. To ensure the seal effect of the cable gland (IP protection rating), find out which cable outer diameter the cable gland is suitable for.

Use a cable gland fitting the cable diameter.

Make sure that the entire installation is carried out according to the Profibus specification. In particular, make sure that the bus is terminated with suitable terminating resistors.

You can find detailed information of the cable specification, installation and topology in the " *Profibus PA - User and Installation Guide-line*" on [www.profibus.com](http://www.profibus.com).

#### Cable screening and grounding

Make sure that the cable screen and grounding are carried out according to Fieldbus specification. We recommend to connect the cable screening to ground potential on both ends.

In systems with potential equalisation, connect the cable screening directly to ground potential at the power supply unit, in the connection box and at the sensor. The screen in the sensor must be connected directly to the internal ground terminal. The ground terminal outside on the housing must be connected to the potential equalisation (low impedance).

#### Cable glands

#### Metric threads:

In the case of instrument housings with metric thread, the cable glands are screwed in at the factory. They are sealed with plastic plugs as transport protection.



#### Note:

You have to remove these plugs before electrical connection.

**NPT thread:**

In the case of instrument housings with self-sealing NPT threads, it is not possible to have the cable entries screwed in at the factory. The free openings for the cable glands are therefore covered with red dust protection caps as transport protection.

**Note:**

Prior to setup you have to replace these protective caps with approved cable glands or close the openings with suitable blind plugs.

On plastic housings, the NPT cable gland or the Conduit steel tube must be screwed into the threaded insert without grease.

Max. torque for all housings, see chapter " *Technical data*".

## 5.2 Connecting

### Connection technology

The voltage supply and signal output are connected via the spring-loaded terminals in the housing.

Connection to the display and adjustment module or to the interface adapter is carried out via contact pins in the housing.

**Information:**

The terminal block is pluggable and can be removed from the electronics. To do this, lift the terminal block with a small screwdriver and pull it out. When reinserting the terminal block, you should hear it snap in.

### Connection procedure

Proceed as follows:

1. Unscrew the housing lid
2. If a display and adjustment module is installed, remove it by turning it slightly to the left
3. Loosen compression nut of the cable gland and remove blind plug
4. Remove approx. 10 cm (4 in) of the cable mantle, strip approx. 1 cm (0.4 in) of insulation from the ends of the individual wires
5. Insert the cable into the sensor through the cable entry

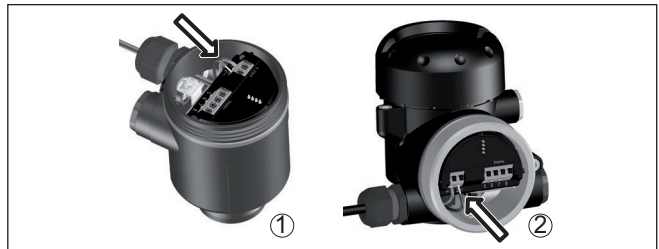

Fig. 19: Connection steps 5 and 6

- 1 Single chamber housing
- 2 Double chamber housing

6. Insert the wire ends into the terminals according to the wiring plan

**Note:**

Solid cores as well as flexible cores with wire end sleeves are inserted directly into the terminal openings. In case of flexible cores without end sleeves, press the terminal from above with a small screwdriver, the terminal opening is then free. When the screwdriver is released, the terminal closes again.

7. Check the hold of the wires in the terminals by lightly pulling on them
8. Connect the shielding to the internal ground terminal, connect the external ground terminal to potential equalisation
9. Tighten the compression nut of the cable entry gland. The seal ring must completely encircle the cable
10. Reinsert the display and adjustment module, if one was installed
11. Screw the housing lid back on

The electrical connection is finished.

### 5.3 Single chamber housing

The following illustration applies to the non-Ex, Ex ia and Ex d version.

Electronics and connection compartment

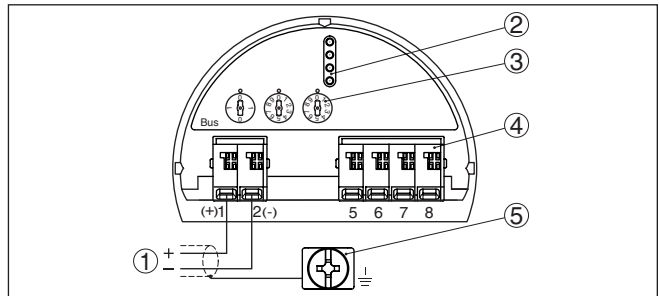

Fig. 20: Electronics and connection compartment - single chamber housing

- 1 Voltage supply, signal output
- 2 For display and adjustment module or interface adapter
- 3 Selection switch for instrument address
- 4 For external display and adjustment unit
- 5 Ground terminal for connection of the cable screening

### 5.4 Double chamber housing



The following illustrations apply to the non-Ex as well as to the Ex-ia version.

Electronics compartment

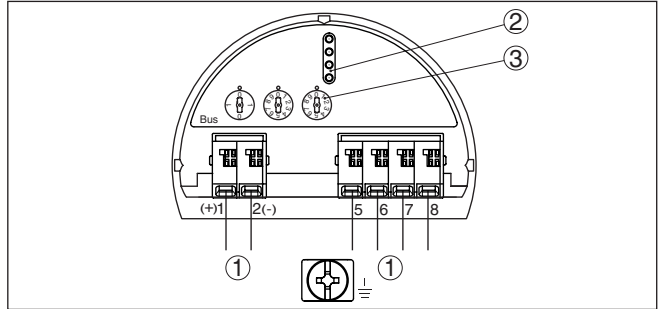

Fig. 21: Electronics compartment - double chamber housing

- 1 Internal connection to the connection compartment
- 2 Contact pins for the display and adjustment module or interface adapter
- 3 Selection switch for bus address

Connection compartment

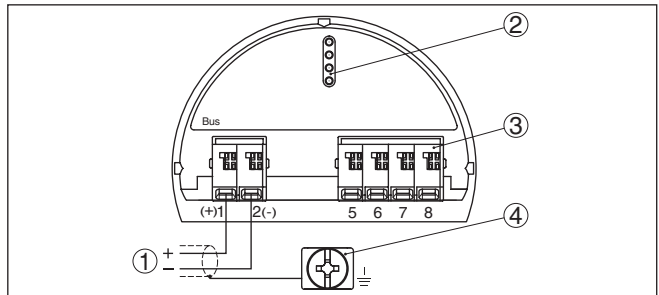

Fig. 22: Connection compartment - double chamber housing

- 1 Voltage supply, signal output
- 2 For display and adjustment module or interface adapter
- 3 For external display and adjustment unit
- 4 Ground terminal for connection of the cable screening

### 5.5 Housing IP66/IP68 (1 bar)

Wire assignment, connection cable

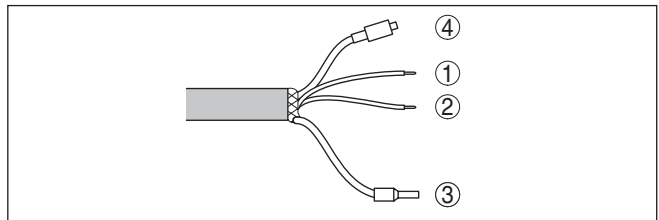

Fig. 23: Wire assignment, connection cable

- 1 Brown (+): to voltage supply or to the processing system
- 2 Blue (-): to voltage supply or to the processing system
- 3 Shielding
- 4 Breather capillaries with filter element

## 5.6 External housing with version IP68 (25 bar)

### Overview

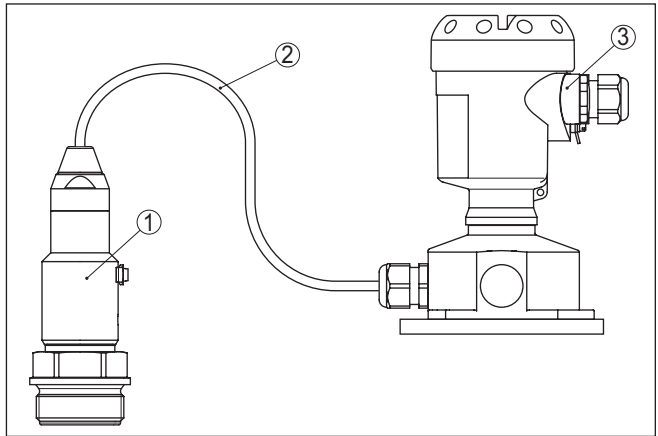

Fig. 24: CPT-2x in IP68 version 25 bar with axial cable outlet, external housing

- 1 Transmitter
- 2 Connection cable
- 3 External housing

### Electronics and connection compartment for power supply

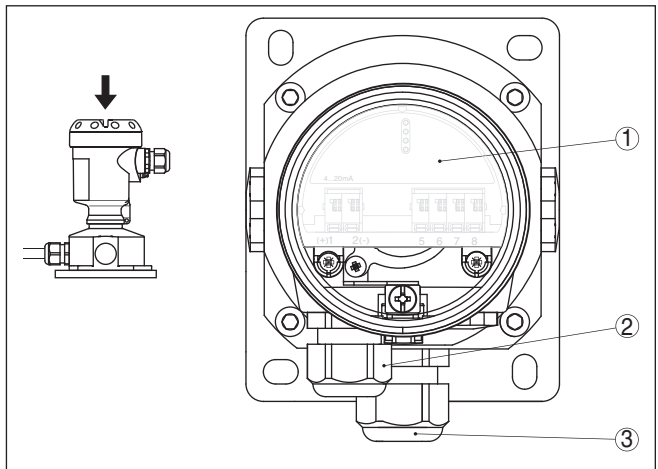

Fig. 25: Electronics and connection compartment

- 1 Electronics module
- 2 Cable gland for voltage supply
- 3 Cable gland for connection cable, transmitter



**Terminal compartment, housing socket**

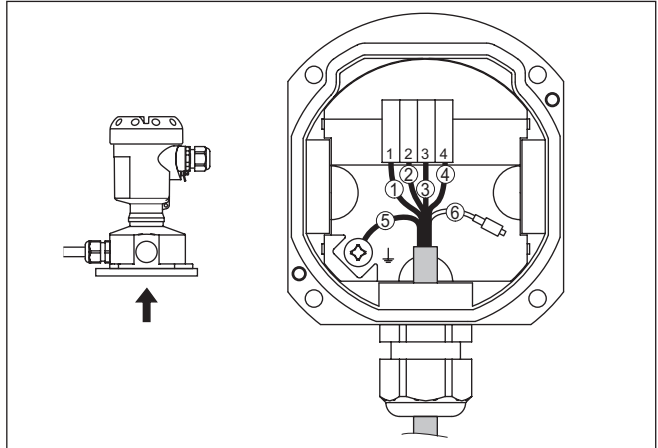

Fig. 26: Connection of the process component in the housing base

- 1 Yellow
- 2 White
- 3 Red
- 4 Black
- 5 Shielding
- 6 Breather capillaries

**Electronics and connection compartment**

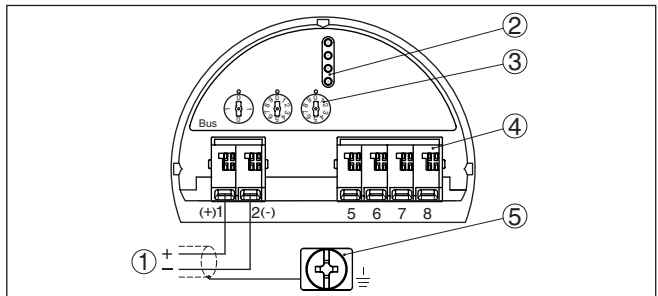

Fig. 27: Electronics and connection compartment - single chamber housing

- 1 Voltage supply, signal output
- 2 For display and adjustment module or interface adapter
- 3 Selection switch for instrument address
- 4 For external display and adjustment unit
- 5 Ground terminal for connection of the cable screening

**5.7 Switch-on phase**

After connecting the instrument to power supply or after a voltage recurrence, the instrument carries out a self-check:

- Internal check of the electronics
- Indication of a status message on the display or PC

Then the actual measured value is output to the signal cable. The value takes into account settings that have already been carried out, e.g. default setting.

## 6 Set up with the display and adjustment module

### 6.1 Insert display and adjustment module

The display and adjustment module can be inserted into the sensor and removed again at any time. You can choose any one of four different positions - each displaced by 90°. It is not necessary to interrupt the power supply.

Proceed as follows:

1. Unscrew the housing lid
2. Place the display and adjustment module on the electronics in the desired position and turn it to the right until it snaps in.
3. Screw housing lid with inspection window tightly back on

Disassembly is carried out in reverse order.

The display and adjustment module is powered by the sensor, an additional connection is not necessary.



*Fig. 28: Installing the display and adjustment module in the electronics compartment of the single chamber housing*

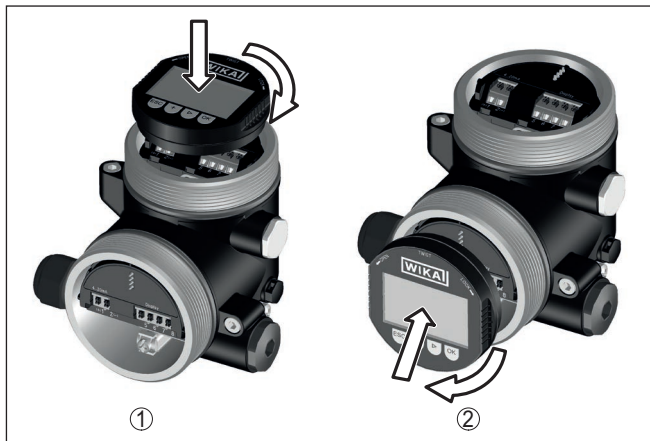

Fig. 29: Installing the display and adjustment module in the double chamber housing

- 1 In the electronics compartment
- 2 In the connection compartment



**Note:**

If you intend to retrofit the instrument with a display and adjustment module for continuous measured value indication, a higher lid with an inspection glass is required.

## 6.2 Adjustment system

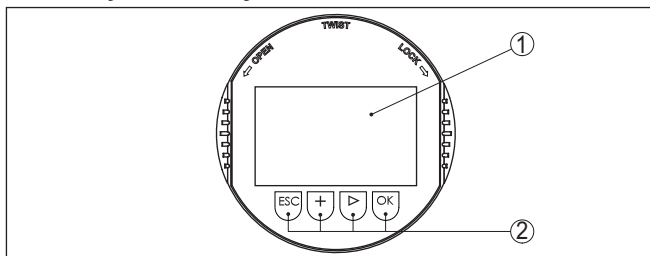

Fig. 30: Display and adjustment elements

- 1 LC display
- 2 Adjustment keys

### Key functions

- **[OK]** key:
  - Move to the menu overview
  - Confirm selected menu
  - Edit parameter
  - Save value
- **[>]** key:
  - Change measured value presentation
  - Select list entry
  - Select menu items

- Select editing position
- **[+]** key:
  - Change value of the parameter
- **[ESC]** key:
  - Interrupt input
  - Jump to next higher menu

**Adjustment system**

The instrument is operated via the four keys of the display and adjustment module. The individual menu items are shown on the LC display. You can find the function of the individual keys in the previous illustration.

**Time functions**

When the **[+]** and **[->]** keys are pressed quickly, the edited value, or the cursor, changes one value or position at a time. If the key is pressed longer than 1 s, the value or position changes continuously.

When the **[OK]** and **[ESC]** keys are pressed simultaneously for more than 5 s, the display returns to the main menu. The menu language is then switched over to "English".

Approx. 60 minutes after the last pressing of a key, an automatic reset to measured value indication is triggered. Any values not confirmed with **[OK]** will not be saved.

**6.3 Measured value indication**

**Measured value indication**

With the **[->]** key you can move between three different indication modes.

In the first view, the selected measured value is displayed in large digits.

In the second view, the selected measured value and a respective bargraph presentation are displayed.

In the third view, the selected measured value as well as a second selectable value, e.g. the temperature, are displayed.



With the "OK" key you move (during the initial setup of the instrument) to the selection menu "Language".

**Selection language**

In this menu item, you can select the national language for further parameterization.

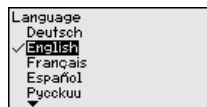

With the "[->]" button, you can select the requested language, with "OK" you confirm the selection and move to the main menu.

You can change your selection afterwards with the menu item " *Setup - Display, Menu language*".

## 6.4 Parameter adjustment - Quick setup

To quickly and easily adapt the sensor to the application, select the menu item " *Quick setup*" in the start graphic on the display and adjustment module.



Select the individual steps with the [->] key.

After the last step, " *Quick setup terminated successfully*" is displayed briefly.

The return to the measured value indication is carried out through the [->] or [ESC] keys or automatically after 3 s



### Note:

You can find a description of the individual steps in the quick setup guide of the sensor.

You can find " *Extended adjustment*" in the next sub-chapter.

## 6.5 Parameter adjustment - Extended adjustment

For technically demanding measuring points, you can carry out extended settings in " *Extended adjustment*".



## Main menu

The main menu is divided into five sections with the following functions:

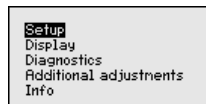

**Setup:** Settings, for example, to measurement loop name, application, units, position correction, adjustment, AI FB 1 Channel - scaling - damping

**Display:** Settings, e.g., for language, measured value display, lighting

**Diagnosis:** Information, e.g. on instrument status, peak indicator, measurement reliability, AI FB 1 simulation

**Additional adjustments:** PIN, date/time, reset, copy function

**Info:** Instrument name, hardware and software version, date of manufacture, sensor features

To ensure optimum adjustment of the measurement, the individual submenu items in the main menu " *Setup*" should be selected one

after the other and provided with the correct parameters. The menu items are described in the following.

### 6.5.1 Setup

#### Instrument address

An address must be assigned to each Profibus PA instrument. Each address may only be assigned once in the Profibus PA network. The sensor is only recognized by the control system if the address is set correctly.

When the instrument is shipped, address 126 is set. This address can be used to test the function of the instrument and to connect it to a Profibus PA network. Then the address must be changed to integrate additional instruments.

The address setting is carried out either via:

- The address selection switch in the electronics compartment of the instrument (address setting via hardware)
- The display and adjustment module (address setting via software)
- PACTware/DTM (address setting via software)

#### Hardware addressing

Hardware addressing is effective if an address less than 126 is set with the address selection switches on the electronics module of CPT-2x. In such case, software addressing has no effect - only the set hardware address applies.

#### Software addressing

Software addressing is only effective if address 126 or higher is set on the instrument with the address selection switches.



#### Measurement loop name

In the menu item " *Sensor TAG*" you edit a twelve-digit measurement loop designation.

You can enter an unambiguous designation for the sensor, e.g. the measurement loop name or the tank or product designation. In digital systems and in the documentation of larger plants, a singular designation must be entered for exact identification of individual measuring points.

The available digits include:

- Letters from A ... Z
- Numbers from 0 ... 9
- Special characters +, -, /, -

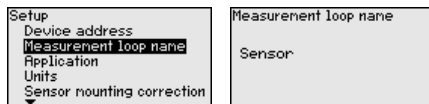

#### Application

In this menu item you activate/deactivate the Secondary sensor for electronic differential pressure and select the application.

CPT-2x can be used for process pressure and level measurement. Default setting is process pressure measurement. The mode can be changed in this adjustment menu.

If you have connected **no** Secondary sensor, you confirm this with "*Deactivate*".

Depending on the selected application, different subchapters in the following adjustment steps are important. There you can find the individual adjustment steps.

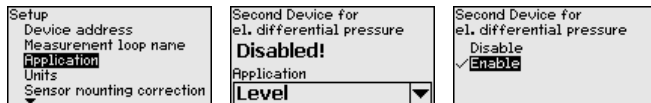

Enter the requested parameters via the appropriate keys, save your settings with **[OK]** and jump to the next menu item with the **[ESC]** and the **[->]** key.

## Units

In this menu item, the adjustment units of the instrument are determined. The selection determines the unit displayed in the menu items "*Min. adjustment (Zero)*" and "*Max. adjustment (Span)*".

### Unit of measurement:

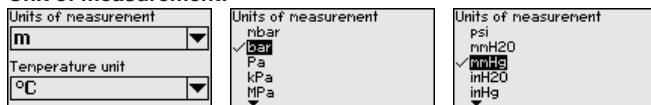

If the level should be adjusted in a height unit, the density of the medium must also be entered later during the adjustment.

In addition, the temperature unit of the instrument is specified. The selection determines the unit displayed in menu items "*Peak indicator, temperature*" and "in the variables of the digital output signal".

### Temperature unit:

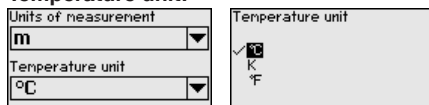

Enter the requested parameters via the appropriate keys, save your settings with **[OK]** and jump to the next menu item with the **[ESC]** and the **[->]** key.

## Position correction

Especially with chemical seal systems, the installation position of the instrument can shift (offset) the measured value. Position correction compensates this offset. In the process, the actual measured value is taken over automatically. With relative pressure measuring cells a manual offset can also be carried out.





If the actual measured value should be taken over as correction value during automatic position correction, this value must not be influenced by product coverage or static pressure.

With the manual position correction, the offset value can be determined by the user. Select for this purpose the function "Edit" and enter the requested value.

Save your settings with [OK] and move with [ESC] and [->] to the next menu item.

After the position correction is carried out, the actual measured value is corrected to 0. The corrective value appears with an inverse sign as offset value in the display.

The position correction can be repeated as often as necessary. However, if the sum of the corrective values exceeds 20 % of the nominal measuring range, then no position correction is possible.

## Adjustment

CPT-2x always measures pressure independently of the process variable selected in the menu item "Application". To output the selected process variable correctly, an allocation of the output signal to 0 % and 100 % must be carried out (adjustment).

With the application "Level", the hydrostatic pressure, e.g. with full and empty vessel, is entered for adjustment. See following example:

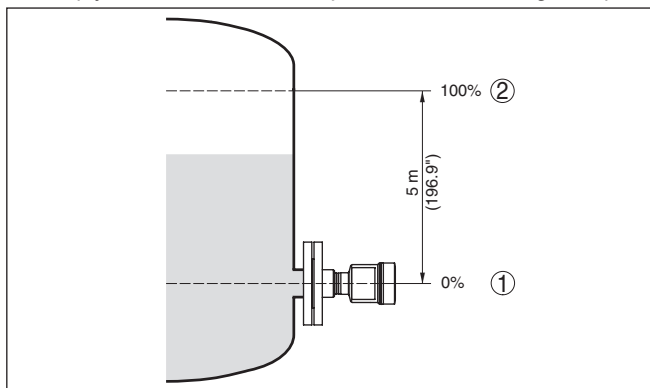

Fig. 31: Parameter adjustment example Min./max. adjustment, level measurement

1 Min. level = 0 % corresponds to 0.0 mbar

2 Max. level = 100 % corresponds to 490.5 mbar

If these values are not known, an adjustment with filling levels of e.g. 10 % and 90 % is also possible. By means of these settings, the real filling height is then calculated.

The actual product level during this adjustment is not important, because the min./max. adjustment is always carried out without changing the product level. These settings can be made ahead of time without the instrument having to be installed.

**Note:**

If the adjustment ranges are exceeded, the entered value will not be accepted. Editing can be interrupted with **[ESC]** or corrected to a value within the adjustment ranges.

For the other process variables such as e.g. process pressure, differential pressure or flow, the adjustment is performed in like manner.

**Zero adjustment**

Proceed as follows:

1. Select the menu item "Setup" with **[->]** and confirm with **[OK]**.  
Now select with **[->]** the menu item "Zero adjustment" and confirm with **[OK]**.

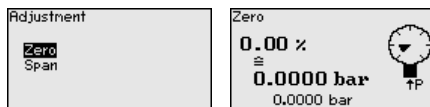

2. Edit the mbar value with **[OK]** and set the cursor to the requested position with **[->]**.

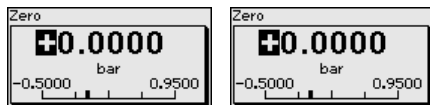

3. Set the requested mbar value with **[+]** and store with **[OK]**.
4. Change with **[ESC]** and **[->]** to the span adjustment

The zero adjustment is finished.

**Information:**

The Zero adjustment shifts the value of the span adjustment. The span, i.e. the difference between these values, however, remains unchanged.

For an adjustment with pressure, simply enter the actual measured value indicated at the bottom of the display.

If the adjustment ranges are exceeded, the message "Outside parameter limits" appears. The editing procedure can be aborted with **[ESC]** or the displayed limit value can be accepted with **[OK]**.

**Span adjustment**

Proceed as follows:

1. Select with **[->]** the menu item "Span adjustment" and confirm with **[OK]**.

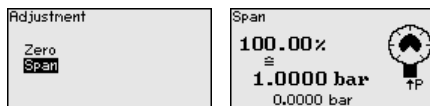

2. Edit the mbar value with **[OK]** and set the cursor to the requested position with **[->]**.

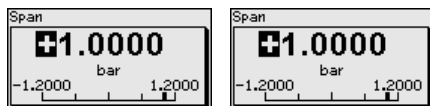

- Set the requested mbar value with **[+]** and store with **[OK]**.

For an adjustment with pressure, simply enter the actual measured value indicated at the bottom of the display.

If the adjustment ranges are exceeded, the message " *Outside parameter limits*" appears. The editing procedure can be aborted with **[ESC]** or the displayed limit value can be accepted with **[OK]**.

The span adjustment is finished.

### Min. adjustment - Level

Proceed as follows:

- Select the menu item " *Setup*" with **[->]** and confirm with **[OK]**.  
Now select with **[->]** the menu item " *Adjustment*", then " *Min. adjustment*" and confirm with **[OK]**.

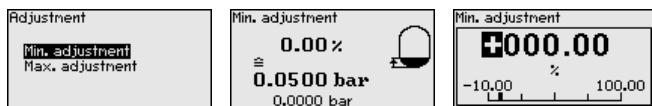

- Edit the percentage value with **[OK]** and set the cursor to the requested position with **[->]**.
- Set the requested percentage value (e.g. 10 %) with **[+]** and save with **[OK]**. The cursor jumps now to the pressure value.
- Enter the pressure value corresponding to the min. level (e.g. 0 mbar).
- Save settings with **[OK]** and move with **[ESC]** and **[->]** to the max. adjustment.

The min. adjustment is finished.

For an adjustment with filling, simply enter the actual measured value indicated at the bottom of the display.

### Max. adjustment - Level

Proceed as follows:

- Select with **[->]** the menu item " *Max. adjustment*" and confirm with **[OK]**.

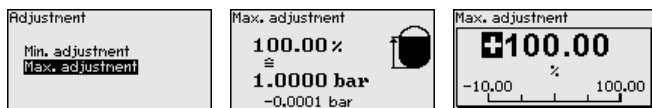

- Edit the percentage value with **[OK]** and set the cursor to the requested position with **[->]**.
- Set the requested percentage value (e.g. 90 %) with **[+]** and save with **[OK]**. The cursor jumps now to the pressure value.
- Enter the pressure value for the full vessel (e.g. 900 mbar) corresponding to the percentage value.
- Save settings with **[OK]**

The max. adjustment is finished.

For an adjustment with filling, simply enter the actual measured value indicated at the bottom of the display.

### Linearisation

A linearization is necessary for all vessels in which the vessel volume does not increase linearly with the level - e.g. a horizontal cylindrical or spherical tank - and the indication or output of the volume is required. Corresponding linearization curves are preprogrammed for these vessels. They represent the correlation between the level percentage and vessel volume. The linearization applies to the measured value indication and the current output.

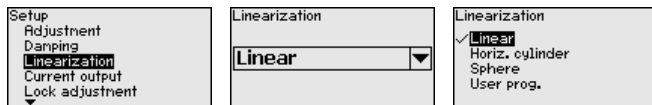

### AI FB1

Since the parameter adjustment of the Function Block 1 (FB1) is very comprehensive, it was divided into various submenu items.

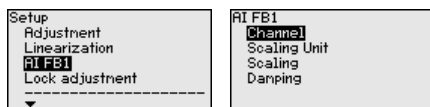

### AI FB1 - Channel

In menu item "Channel" you determine the input signal for further processing in AI FB 1.

As input signals, the output values of Transducer Block (TB) can be selected.

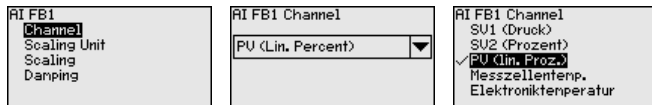

### AI FB1 - scaling unit

In the menu item "Scaling unit" you define the scaling variable and scaling unit of the output value of FB 1.

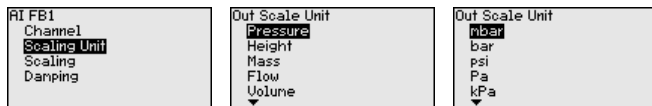

### AI FB1 - scaling

In the menu item "Scaling", you assign the min. and max. values of the input signal (Channel) to the respective values of the output (Out Scale). The units correspond to the previous selection.

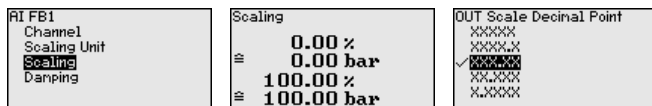

Min. values for PV lin Proc. and Out Scale process pressure in bar:

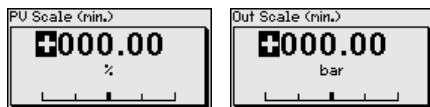

Max. values for PV lin Proc. and Out Scale process pressure in bar:

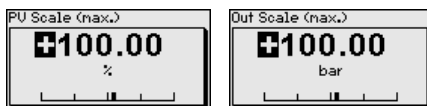

### AI FB1 - damping

To damp process-dependent measured value fluctuations, set a damping of 0 ... 999 s in this menu item. The increment is 0.1 s.

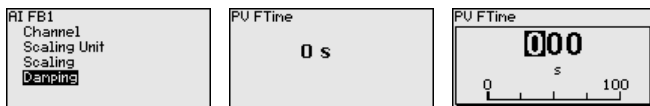

The default setting is a damping of 0 s.

### Lock/Unlock adjustment

In the menu item "Lock/unlock adjustment" you safeguard the sensor parameters against unauthorized or unintentional modifications.

This is done by entering a four-digit PIN.

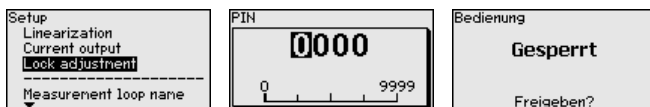

With active PIN, only the following adjustment functions are possible without entering a PIN:

- Select menu items and show data
- Read data from the sensor into the display and adjustment module

Releasing the sensor adjustment is also possible in any menu item by entering the PIN.



#### Caution:

With active PIN, adjustment via PACTware/DTM and other systems is also blocked.

## 6.5.2 Display

### Language

This menu item enables the setting of the requested national language.

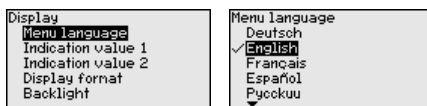

The following languages are available:

- German
- English
- French
- Spanish
- Russian
- Italian
- Dutch
- Portuguese
- Japanese
- Chinese

- Polish
- Czech
- Turkish

In delivery status, the CPT-2x is set to English.

### Display value 1 and 2

In this menu item, you define which measured value is displayed.



The default setting for the display value is " *Lin. percent*".

### Display format 1 and 2

In this menu item you define the number of decimal positions with which the measured value is displayed.

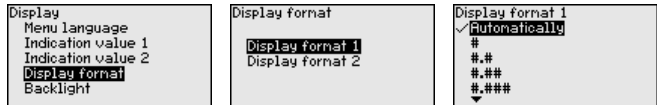

The default setting for the display format is " *Automatic*".

### Backlight

The display and adjustment module has a backlight for the display. In this menu item you can switch on the lighting. You can find the required operating voltage in chapter " *Technical data*".

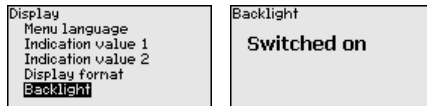

In delivery status, the lighting is switched on.

### Device status

In this menu item, the device status is displayed.

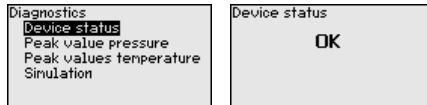

In case of error, e.g. the error code F017, e.g. the error description " *Adjustment span too small*" and a four digit figure are displayed for service purposes. You can find the error codes with description, reason as well as rectification in chapter " *Asset Management*".

## 6.5.3 Diagnostics

### Peak indicator, pressure

The respective min. and max. measured values are saved in the sensor. The two values are displayed in menu item " *Peak indicator, pressure*".

In another window you can carry out a reset of the peak values separately.

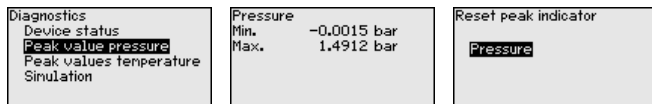

### Peak indicator, temperature

The respective min. and max. measured values of the measuring cell and the electronics temperature are stored in the sensor. In menu item " *Peak indicator, temperature* ", both values are displayed.

In another window you can carry out a reset of the two peak values separately.

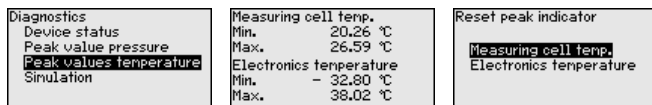

### Simulation

In this menu item you simulate measured values. Hence, the signal path can be tested via the bus system to the input card of the control system.

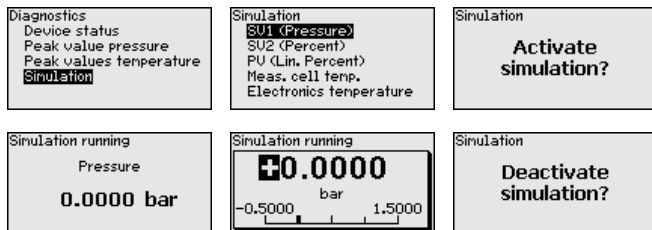

Select the requested simulation variable and set the requested value.

To deactivate the simulation, you have to push the **[ESC]** key and confirm the message " *Deactivate simulation* " with the **[OK]** key.



#### Caution:

During simulation, the simulated value is output as digital signal. The status message along with the Asset Management function is " *Maintenance* ".



#### Information:

The sensor terminates the simulation automatically after 60 minutes.

### 6.5.4 Additional adjustments

#### Date/Time

In this menu item, you adjust the internal clock of the sensor. There is no adjustment for summer/winter (daylight saving) time.

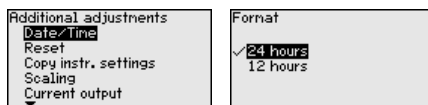

#### Reset

After a reset, certain parameter adjustments made by the user are reset.

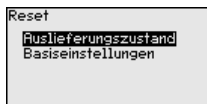

The following reset functions are available:

**Delivery status:** Restores the parameter settings at the time of shipment from the factory, incl. the order-specific settings. Any user-defined linearisation curve as well as the measured value memory are deleted.

**Basic settings:** Resets the parameter settings, incl. special parameters, to the default values of the respective instrument. Any programmed linearisation curve as well as the measured value memory are deleted.



**Note:**

You can find the default values of the device in chapter " *Menu overview*".

### Copy instrument settings

The instrument settings are copied with this function. The following functions are available:

- **Read from sensor:** Read data from sensor and store into the display and adjustment module
- **Write into sensor:** Store data from the display and adjustment module back into the sensor

The following data or settings for adjustment of the display and adjustment module are saved:

- All data of the menu " *Setup*" and " *Display*"
- In the menu " *Additional adjustments*" the items " *Reset*, *Date/Time*"
- The user-programmable linearization curve

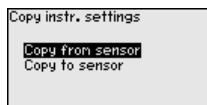
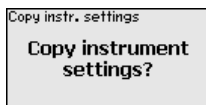
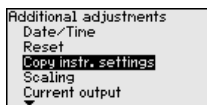

The copied data are permanently saved in an EEPROM memory in the display and adjustment module and remain there even in case of power failure. From there, they can be written into one or more sensors or kept as backup for a possible electronics exchange.



**Note:**

Before the data are saved in the sensor, a safety check is carried out to determine if the data match the sensor. In the process the sensor type of the source data as well as the target sensor are displayed. If the data do not match, a fault message is outputted or the function is blocked. The data are saved only after release.

### Special parameters

In this menu item you gain access to the protected area where you can enter special parameters. In exceptional cases, individual parameters can be modified in order to adapt the sensor to special requirements.



Change the settings of the special parameters only after having contacted our service staff.

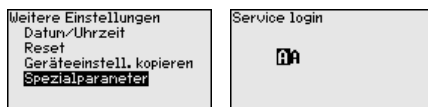

### 6.5.5 Info

#### Device name

In this menu item, you can read out the instrument name and the instrument serial number:

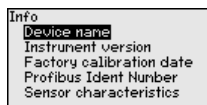

#### Instrument version

In this menu item, the hardware and software version of the sensor is displayed.

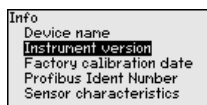

#### Factory calibration date

In this menu item, the date of factory calibration of the sensor as well as the date of the last change of sensor parameters are displayed via the display and adjustment module or via the PC.

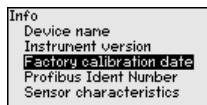

#### Profibus ident number

In this menu item, the Profibus ident number of the sensor is displayed.

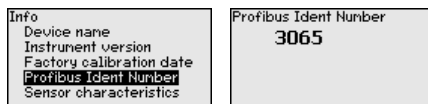

#### Sensor characteristics

In this menu item, the features of the sensor such as approval, process fitting, seal, measuring range, electronics, housing and others are displayed.

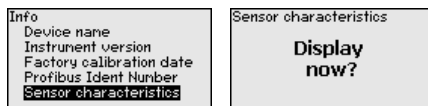

## 6.6 Save parameter adjustment data

#### On paper

We recommended writing down the adjustment data, e.g. in this operating instructions manual, and archiving them afterwards. They are thus available for multiple use or service purposes.

### **In the display and adjustment module**

If the instrument is equipped with a display and adjustment module, the parameter adjustment data can be saved therein. The procedure is described in menu item "*Copy device settings*".

## 7 Diagnosis, asset management and service

### 7.1 Maintenance

#### Maintenance

If the device is used properly, no special maintenance is required in normal operation.

#### Precaution measures against buildup

In some applications, product buildup on the diaphragm can influence the measuring result. Depending on the sensor and application, take precautions to ensure that heavy buildup, and especially a hardening thereof, is avoided.

#### Cleaning

The cleaning helps that the type label and markings on the instrument are visible.

Take note of the following:

- Use only cleaning agents which do not corrode the housings, type label and seals
- Use only cleaning methods corresponding to the housing protection rating

### 7.2 Cleaning - hygienic connection with compression nut

#### Overview

The hygienic connection with compression nut can be disassembled and the diaphragm cleaned.

The following graphic shows the structure:

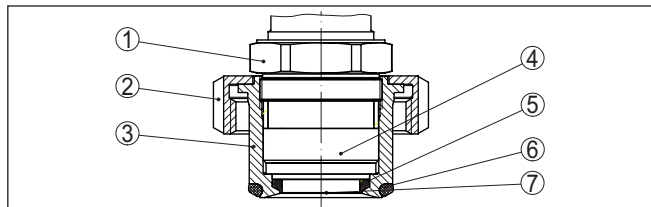

Fig. 32: CPT-2x, structure of the hygienic connection with compression nut

- 1 Hexagon
- 2 Compression nut
- 3 Process fitting
- 4 Process module
- 5 Form seal for the measuring cell
- 6 O-ring seal for the process fitting
- 7 Diaphragm

#### Procedure

To do so, proceed as follows:

1. Loosen compression nut and remove the pressure transmitter from the welded socket
2. Remove the O-ring seal for the process fitting
3. Clean the diaphragm with brass brush and cleaning detergent
4. Loosen the hexagon and remove the process component from the process fitting

5. Remove the form seal for the measuring cell and remove it by a new one
6. Screw the process component into the process fitting, tighten the hexagon (wrench size see chapter " *Dimensions*", max. torque see chapter " *Technical data*")
7. Insert new O-ring seal for the process fitting
8. Install the process pressure transmitter in the welded socket, tighten compression nut

The cleaning is finished.

The pressure transmitter is directly ready for operation, a fresh adjustment is not required.

### 7.3 Diagnosis memory

The instrument has several memories available for diagnostic purposes. The data remain there even in case of voltage interruption.

#### Measured value memory

Up to 100,000 measured values can be stored in the sensor in a ring memory. Each entry contains date/time as well as the respective measured value.

Depending on the instrument version, values that can be stored are for example:

- Level
- Process pressure
- Differential pressure
- Static pressure
- Percentage value
- Scaled values
- Current output
- Lin. percent
- Measuring cell temperature
- Electronics temperature

When the instrument is shipped, the measured value memory is active and stores pressure value and measuring cell temperature every 10 s, with electronic differential pressure also the static pressure.

The requested values and recording conditions are set via a PC with PACTware/DTM or the control system with EDD. Data are thus read out and also reset.

#### Event memory

Up to 500 events are automatically stored with a time stamp in the sensor (non-deletable). Each entry contains date/time, event type, event description and value.

Event types are for example:

- Modification of a parameter
- Switch-on and switch-off times
- Status messages (according to NE 107)
- Error messages (according to NE 107)

The data are read out via a PC with PACTware/DTM or the control system with EDD.

## 7.4 Asset Management function

The instrument features self-monitoring and diagnostics according to NE 107 and VDI/VDE 2650. In addition to the status messages in the following tables there are more detailed error messages available under the menu item "Diagnostics" via the respective adjustment module.

### Status messages

The status messages are divided into the following categories:

- Failure
- Function check
- Out of specification
- Maintenance required

and explained by pictographs:

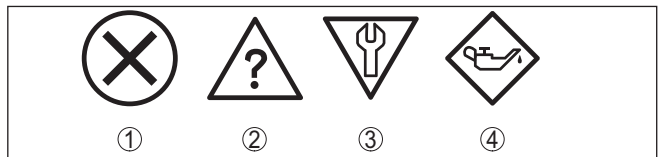

Fig. 33: Pictographs of the status messages

- 1 Failure - red
- 2 Out of specification - yellow
- 3 Function check - orange
- 4 Maintenance required - blue

#### Malfunction (Failure):

Due to a malfunction in the instrument, a fault signal is output.

This status message is always active. It cannot be deactivated by the user.

#### Function check:

The instrument is being worked on, the measured value is temporarily invalid (for example during simulation).

This status message is inactive by default.

#### Out of specification:

The measured value is unreliable because an instrument specification was exceeded (e.g. electronics temperature).

This status message is inactive by default.

#### Maintenance required:

Due to external influences, the instrument function is limited. The measurement is affected, but the measured value is still valid. Plan in maintenance for the instrument because a failure is expected in the near future (e.g. due to buildup).

This status message is inactive by default.

## Failure

Code Text message	Cause	Rectification	DevSpec Diagnosis Bits
F013 No valid measured value available	Gauge pressure or low pressure Measuring cell defective	Exchange measuring cell Send instrument for repair	Bit 0
F017 Adjustment span too small	Adjustment not within specification	Change the adjustment according to the limit values	Bit 1
F025 Error in the linearization table	Index markers are not continuously rising, for example illogical value pairs	Check linearization table Delete table/Create new	Bit 2
F036 no operable sensor software	Failed or interrupted software update	Repeat software update Check electronics version Exchanging the electronics Send instrument for repair	Bit 3
F040 Error in the electronics	Hardware defect	Exchanging the electronics Send instrument for repair	Bit 4
F041 Communication error	No connection to the sensor electronics	Check connection between sensor and main electronics (with separate version)	Bit 13
F042 Communication error Secondary sensor	No connection to the Secondary sensor	Check connection between Primary and Secondary sensor	Bit 28 of Byte 0 ... 5
F080 General software error	General software error	Disconnect operating voltage briefly	Bit 5
F105 Measured value is determined	The instrument is still in the switch-on phase, the measured value could not yet be determined	Wait for the end of the switch-on phase	Bit 6
F113 Communication error	Error in the internal instrument communication	Disconnect operating voltage briefly Send instrument for repair	Bit 12
F260 Error in the calibration	Error in the calibration carried out in the factory Error in the EEPROM	Exchanging the electronics Send instrument for repair	Bit 8
F261 Error in the instrument settings	Error during setup Error when carrying out a reset	Repeat setup Repeat reset	Bit 9
F264 Installation/Setup error	Inconsistent settings (e.g.: distance, adjustment units with application process pressure) for selected application  Invalid sensor configuration (e.g.: application electronic differential pressure with connected differential pressure measuring cell)	Modify settings Modify connected sensor configuration or application	Bit 10

Code Text message	Cause	Rectification	DevSpec Diagnosis Bits
F265 Measurement function disturbed	Sensor no longer carries out a measurement	Carry out a reset Disconnect operating voltage briefly	Bit 11

Tab. 1: Error codes and text messages, information on causes as well as corrective measures

### Function check

Code Text message	Cause	Rectification	DevSpec Diagnosis Bits
C700 Simulation active	A simulation is active	Finish simulation Wait for the automatic end after 60 mins.	Bit 27

### Out of specification

Code Text message	Cause	Rectification	DevSpec Diagnosis Bits
S600 Impermissible electronics temperature	Temperature of the electronics in the non-specified range	Check ambient temperature Insulate electronics Use instrument with higher temperature range	Bit 23
S603 Impermissible operating voltage	Operating voltage below specified range	Check electrical connection If necessary, increase operating voltage	Bit 26
S605 Impermissible pressure value	Measured process pressure below or above the adjustment range	Check nominal measuring range of the instrument If necessary, use an instrument with a higher measuring range	Bit 29

### Maintenance

Code Text message	Cause	Rectification	DevSpec Diagnosis Bits
M500 Error in the delivery status	The data could not be restored during the reset to delivery status	Repeat reset Load XML file with sensor data into the sensor	Bit 15
M501 Error in the non-active linearisation table	Index markers are not continuously rising, for example illogical value pairs	Check linearization table Delete table/Create new	Bit 16
M502 Error in the event memory	Hardware error EEPROM	Exchanging the electronics Send instrument for repair	Bit 17
M504 Error at a device interface	Hardware defect	Exchanging the electronics Send instrument for repair	Bit 19

Code Text message	Cause	Rectification	DevSpec Diagnosis Bits
M507 Error in the instrument settings	Error during setup Error when carrying out a reset	Carry out reset and repeat setup	Bit 22

## 7.5 Rectify faults

### Reaction when malfunction occurs

The operator of the system is responsible for taking suitable measures to rectify faults.

### Fault rectification

The first measures are:

- Evaluation of fault messages
- Checking the output signal
- Treatment of measurement errors

Further comprehensive diagnostics options are available with a PC/notebook with PACTware and the suitable DTM. In many cases, the reasons can be determined in this way and faults rectified.

### Reaction after fault rectification

Depending on the reason for the fault and the measures taken, the steps described in chapter "Setup" must be carried out again or must be checked for plausibility and completeness.

## 7.6 Exchange process module on version IP68 (25 bar)

On version IP68 (25 bar), the user can exchange the process module on site. Connection cable and external housing can be kept.

Required tools:

- Hexagon key wrench, size 2



#### Caution:

The exchange may only be carried out in the complete absence of line voltage.



In Ex applications, only a replacement part with appropriate Ex approval may be used.



#### Caution:

During exchange, protect the inner side of the parts against contamination and moisture.

Proceed as follows when carrying out the exchange:

1. Loosen the fixing screw with the hexagon key wrench
2. Carefully detach the cable assembly from the process module



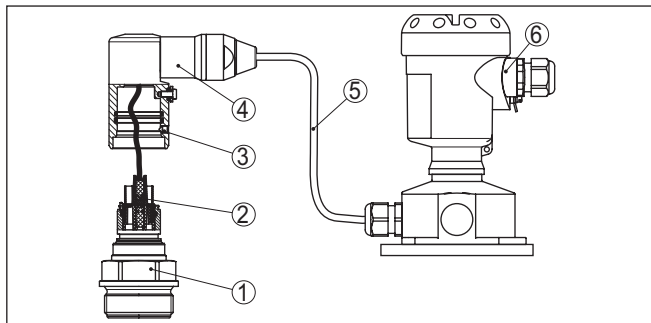

Fig. 34: CPT-2x in IP68 version, 25 bar and lateral cable outlet, external housing

- 1 Process module
- 2 Plug connector
- 3 Fixing screw
- 4 Cable assembly
- 5 Connection cable
- 6 External housing

3. Loosen the plug connector
  4. Mount the new process module on the measuring point
  5. Plug the connector back in
  6. Mount the cable assembly on the process module and turn it to the desired position
  7. Tighten the fixing screw with the hexagon key wrench
- The exchange is finished.

## 7.7 Instrument repair

You can find information for a return shipment under "Service" on our local website.

If a repair is necessary, please proceed as follows:

- Complete one form for each instrument
- If necessary, state a contamination
- Clean the instrument and pack it damage-proof
- Attach the completed form and possibly also a safety data sheet to the instrument

## 8 Dismount

### 8.1 Dismounting steps

To remove the device, carry out the steps in chapters " *Mounting*" and " *Connecting to power supply*" in reverse.



**Warning:**

When dismantling, pay attention to the process conditions in vessels or pipelines. There is a risk of injury, e.g. due to high pressures or temperatures as well as aggressive or toxic media. Avoid this by taking appropriate protective measures.

### 8.2 Disposal



Pass the instrument on to a specialised recycling company and do not use the municipal collecting points.

Remove any batteries in advance, if they can be removed from the device, and dispose of them separately.

If personal data is stored on the old device to be disposed of, delete it before disposal.

If you have no way to dispose of the old instrument properly, please contact us concerning return and disposal.

## 9 Supplement

### 9.1 Technical data

#### Note for approved instruments

The technical data in the respective safety instructions which are included in delivery are valid for approved instruments (e.g. with Ex approval). These data can differ from the data listed herein, for example regarding the process conditions or the voltage supply.

All approval documents can be downloaded from our homepage.

#### Materials and weights

##### Materials, wetted parts

Process fitting	316L, PVDF, PEEK, Alloy C22 (2.4602), Alloy C276 (2.4819), Duplex steel (1.4462), Titanium Grade 2
Diaphragm	Sapphire-ceramic® (> 99.9 % Al <sub>2</sub> O <sub>3</sub> ceramic)
Joining material measuring cell	Glass (with double and form seal, non-wetted parts)
Measuring cell seal	
– Standard (O-ring seal)	FKM (VP2/A, A+P 70.16), EPDM (A+P 70.10-02), FFKM (Kalrez 6375, Perlast G74S, Perlast G75B)
– Hygienic fitting with compression nut (form seal)	FKM (ET 6067), EPDM (EPDM 7076), FFKM (Perlast G75 LT), FEPM (Fluoraz SD890)
Seal for process fitting (in the scope of delivery)	
– Thread G½ (EN 837), G1½ (DIN 3852-A)	Klingersil C-4400
– Thread M44 x 1.25 (DIN 13), M30 x 1.5	FKM, FFKM, EPDM
– Hygienic connection with compression nut	FKM, EPDM, FFKM, FEPM
Surface quality, hygienic fittings, typ.	
– Process fitting	R <sub>a</sub> < 0.8 µm
– Diaphragm	R <sub>a</sub> < 0.5 µm

##### Materials, non-wetted parts

##### Sensor housing

– Housing	Plastic PBT (Polyester), Aluminium AlSi10Mg (powder-coated, basis: Polyester), 316L
– Cable gland	PA, stainless steel, brass
– Cable gland: Seal, closure	NBR, PA
– Seal, housing lid	Silicone SI 850 R, NBR silicone-free
– Inspection window housing cover	Polycarbonate (UL-746-C listed), glass <sup>1)</sup>
– Ground terminal	316L
External housing - deviating materials	
– Housing and socket	Plastic PBT (Polyester), 316L

<sup>1)</sup> Glass with Aluminium and stainless steel (precision casting) housing

– Socket seal	EPDM
– Seal below wall mounting plate <sup>2)</sup>	EPDM
– Inspection window housing cover	Polycarbonate (UL-746-C listed)
Ground terminal	316Ti/316L
Connection cable with IP68 (25 bar) <sup>3)</sup>	
– Cable cover	PE, PUR
– Type label support on cable	PE hard
Connection cable with IP68 (1 bar) <sup>4)</sup>	PE, PUR

**Weights**

Total weight CPT-2x approx. 0.8 ... 8 kg (1.764 ... 17.64 lbs), depending on process fitting and housing

**Torques**

Max. torque for process fitting

– G½ PVDF	5 Nm (3.688 lbf ft)
– G½ PEEK,	10 Nm (7.376 lbf ft)
– G½, G¾	30 Nm (22.13 lbf ft)
– Fittings according to 3A with ex- changeable sealing	20 Nm (14.75 lbf ft)
– Hygienic fitting with compression nut (hexagon)	40 Nm (29.50 lbf ft)
– G1, M30 x 1.5	50 Nm (36.88 lbf ft)
– G1 for PASVE	100 Nm (73.76 lbf ft)
– G1½	200 Nm (147.5 lbf ft)

Max. torque for screws

– PMC 1", PMC 1¼"	2 Nm (1.475 lbf ft)
– PMC 1½"	5 Nm (3.688 lbf ft)

Max. torque for NPT cable glands and Conduit tubes

– Plastic housing	10 Nm (7.376 lbf ft)
– Aluminium/Stainless steel housing	50 Nm (36.88 lbf ft)

**Input variable**

The specifications are only an overview and refer to the measuring cell. Limitations due to the material and version of the process fitting as well as the selected pressure type are possible. The specifications on the nameplate apply. <sup>5)</sup>

<sup>2)</sup> Only for 316L with 3A approval  
<sup>3)</sup> Between transmitter and external electronics housing.  
<sup>4)</sup> Fix connected to the sensor.  
<sup>5)</sup> Data on overload capability apply for reference temperature.

## Nominal measuring ranges and overload capability in bar/kPa

Nominal range	Overload capability	
	Maximum pressure	Minimum pressure
Gauge pressure		
0 ... +0.025 bar/0 ... +2.5 kPa (only for measuring cell ø 28 mm)	+5 bar/+500 kPa	-0.05 bar/-5 kPa
0 ... +0.1 bar/0 ... +10 kPa	+15 bar/+1500 kPa	-0.2 bar/-20 kPa
0 ... +0.4 bar/0 ... +40 kPa	+30 bar/+3000 kPa	-0.8 bar/-80 kPa
0 ... +1 bar/0 ... +100 kPa	+35 bar/+3500 kPa	-1 bar/-100 kPa
0 ... +2.5 bar/0 ... +250 kPa	+50 bar/+5000 kPa	-1 bar/-100 kPa
0 ... +5 bar/0 ... +500 kPa	+65 bar/+6500 kPa	-1 bar/-100 kPa
0 ... +10 bar/0 ... +1000 kPa	+90 bar/+9000 kPa	-1 bar/-100 kPa
0 ... +25 bar/0 ... +2500 kPa	+125 bar/+12500 kPa	-1 bar/-100 kPa
0 ... +60 bar/0 ... +6000 kPa	+200 bar/+20000 kPa	-1 bar/-100 kPa
0 ... +100 bar/0 ... +10000 kPa (only for measuring cell ø 28 mm)	+200 bar/+20000 kPa	-1 bar/-100 kPa
-1 ... 0 bar/-100 ... 0 kPa	+35 bar/+3500 kPa	-1 bar/-100 kPa
-1 ... +1.5 bar/-100 ... +150 kPa	+40 bar/+4000 kPa	-1 bar/-100 kPa
-1 ... +5 bar/-100 ... +500 kPa	+65 bar/+6500 kPa	-1 bar/-100 kPa
-1 ... +10 bar/-100 ... +1000 kPa	+90 bar/+9000 kPa	-1 bar/-100 kPa
-1 ... +25 bar/-100 ... +2500 kPa	+125 bar/+12500 kPa	-1 bar/-100 kPa
-1 ... +60 bar/-100 ... +6000 kPa	+200 bar/+20000 kPa	-1 bar/-100 kPa
-1 ... +100 bar/-100 ... +10000 kPa (only for measuring cell ø 28 mm)	+200 bar/+20000 kPa	-1 bar/-100 kPa
-0.025 ... +0.025 bar/-2.5 ... +2.5 kPa	+5 bar/+500 kPa	-0.05 bar/-5 kPa
-0.05 ... +0.05 bar/-5 ... +5 kPa	+15 bar/+1500 kPa	-0.2 bar/-20 kPa
-0.2 ... +0.2 bar/-20 ... +20 kPa	+20 bar/+2000 kPa	-0.4 bar/-40 kPa
-0.5 ... +0.5 bar/-50 ... +50 kPa	+35 bar/+3500 kPa	-1 bar/-100 kPa
Absolute pressure		
0 ... 0.1 bar/0 ... 10 kPa	15 bar/1500 kPa	0 bar abs.
0 ... 1 bar/0 ... 100 kPa	35 bar/3500 kPa	0 bar abs.
0 ... 2.5 bar/0 ... 250 kPa	50 bar/5000 kPa	0 bar abs.
0 ... +5 bar/0 ... +500 kPa	65 bar/+6500 kPa	0 bar abs.
0 ... 10 bar/0 ... 1000 kPa	90 bar/9000 kPa	0 bar abs.
0 ... 25 bar/0 ... 2500 kPa	125 bar/12500 kPa	0 bar abs.
0 ... 60 bar/0 ... 6000 kPa	200 bar/20000 kPa	0 bar abs.
0 ... 100 bar/0 ... +10000 kPa (only for measuring cell ø 28 mm)	200 bar/20000 kPa	0 bar abs.

**Nominal measuring ranges and overload capacity in psi**

Nominal range	Overload capability	
	Maximum pressure	Minimum pressure
<b>Gauge pressure</b>		
0 ... +0.4 psig (only for measuring cell ø 28 mm)	+75 psig	-0.7 psig
0 ... +1.5 psig	+225 psig	-3 psig
0 ... +5 psig	+375 psig	-11.50 psig
0 ... +15 psig	+525 psig	-14.51 psig
0 ... +30 psig	+725 psig	-14.51 psig
0 ... +75 psig	+975 psig	-14.51 psig
0 ... +150 psig	+1350 psig	-14.51 psig
0 ... +300 psig	+1900 psig	-14.51 psig
0 ... +900 psig	+2900 psig	-14.51 psig
0 ... +1450 psig (only for measuring cell ø 28 mm)	+2900 psig	-14.51 psig
-14.5 ... 0 psig	+525 psig	-14.51 psig
-14.5 ... +20 psig	+600 psig	-14.51 psig
-14.5 ... +75 psig	+975 psig	-14.51 psig
-14.5 ... +150 psig	+1350 psig	-14.51 psig
-14.5 ... +300 psig	+1900 psig	-14.51 psig
-14.5 ... +900 psig	+2900 psig	-14.51 psig
-14.5 ... +1500 psig (only for measuring cell ø 28 mm)	+2900 psig	-14.51 psig
-0.7 ... +0.7 psig	+75 psig	-2.901 psig
-3 ... +3 psig	+225 psi	-5.800 psig
-7 ... +7 psig	+525 psig	-14.51 psig
<b>Absolute pressure</b>		
0 ... 1.5 psi	225 psig	0 psi
0 ... 15 psi	525 psi	0 psi
0 ... 30 psi	725 psi	0 psi
0 ... 75 psi	975 psi	0 psi
0 ... 150 psi	1350 psi	0 psi
0 ... 300 psi	1900 psi	0 psi
0 ... 900 psi	2900 psi	0 psi
0 ... 1450 psi (only for measuring cell ø 28 mm)	2900 psi	0 psi

**Adjustment ranges**

Specifications refer to the nominal measuring range, pressure values lower than -1 bar cannot be set

Min./Max. adjustment:

- Percentage value -10 ... 110 %

– Pressure value	-20 ... 120 %
Zero/Span adjustment:	
– Zero	-20 ... +95 %
– Span	-120 ... +120 %
– Difference between zero and span	max. 120 % of the nominal range
Max. permissible Turn Down	Unlimited (recommended 20 : 1)

---

### Switch-on phase

---

Start-up time with operating voltage  $U_b$

– $\geq 12$ V DC	$\leq 9$ s
– $< 12$ V DC	$\leq 22$ s

---

### Output variable

---

Output signal	digital output signal, Profibus protocol
Transmission rate	31.25 Kbit/s
Instrument address	126 (default setting)
Damping (63 % of the input variable)	0 ... 999 s, adjustable
Profibus PA profile	3.02
Number of FBs with AI (function blocks with analogue input)	3
Default values	
– 1. FB	Primary Value (pressure linearized in %)
– 2. FB	Secondary Value 1 (pressure)
– 3. FB	Secondary Value 2 (pressure in %)
Current value	
– Non-Ex, Ex ia and Ex d instruments	12 mA, $\pm 0.5$ mA

---

### Dynamic behaviour output

---

Dynamic characteristics depending on medium and temperature

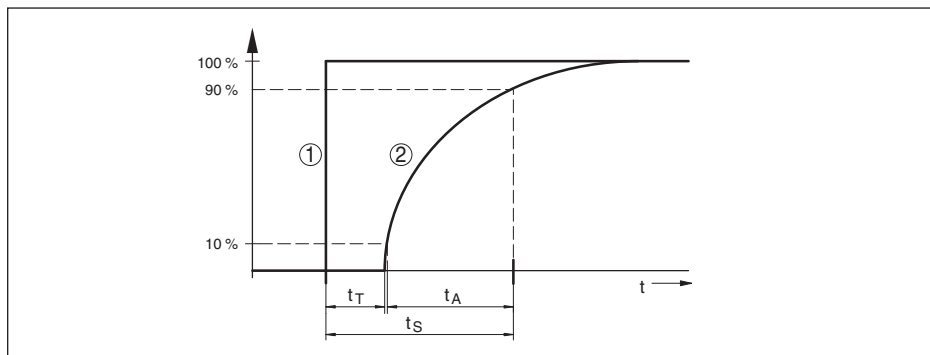

Fig. 35: Behaviour in case of sudden change of the process variable.  $t_T$ : dead time;  $t_A$ : rise time;  $t_S$ : jump response time

- 1 Process variable
- 2 Output signal

	CPT-2x	CPT-2x, IP68 (25 bar), connection cable > 25 m (82.01 ft)
Dead time	≤ 25 ms	≤ 50 ms
Rise time (10 ... 90 %)	≤ 55 ms	≤ 150 ms
Step response time (ti: 0 s, 10 ... 90 %)	≤ 80 ms	≤ 200 ms

Damping (63 % of the input variable) 0 ... 999 s, adjustable via menu item "Damping"

#### Additional output parameter - Measuring cell temperature

Range -60 ... +150 °C (-76 ... +302 °F)

Resolution < 0.2 K

Deviation

- Range of 0 ... +100 °C (+32 ... +212 °F) ±2 K
- Range of -60 ... 0 °C (-76 ... +32 °F) and +100 ... +150 °C (+212 ... +302 °F) typ. ±4 K

Output of the temperature values

- Indication Via the display and adjustment module
- Analogue Via the current output, the additional current output
- Digital Via the digital output signal (depending on the electronics version)

#### Reference conditions and influencing variables (according to DIN EN 60770-1)

Reference conditions according to DIN EN 61298-1

- Temperature +15 ... +25 °C (+59 ... +77 °F)
- Relative humidity 45 ... 75 %
- Air pressure 860 ... 1060 mbar/86 ... 106 kPa (12.5 ... 15.4 psig)



Determination of characteristics	Limit point adjustment according to IEC 61298-2
Characteristic curve	Linear
Reference installation position	upright, diaphragm points downward
Influence of the installation position	< 0.2 mbar/20 Pa (0.003 psig)

**Deviation (according to IEC 60770-1)**

Specifications refer to the set span. Turn down (TD) is the ratio: nominal measuring range/set span.

Accuracy class	Non-linearity, hysteresis and repeatability with TD 1 : 1 up to 5 : 1	Non-linearity, hysteresis and repeatability with 5 : 1
0.05 %	< 0.05 %	< 0.01 % x TD
0.1 %	< 0.1 %	< 0.02 % x TD
0.2 %	< 0.2 %	< 0.04 % x TD

**Influence of the product temperature**

**Thermal change zero signal and output span through product temperature**

Applies to the **digital** signal output (HART, Profibus PA, Foundation Fieldbus) as well as to the **analogue** current output 4 ... 20 mA and refers to the set span. Turn down (TD) is the ratio "nominal measuring range/set span".

The thermal change of the zero signal and output span corresponds to the temperature error  $F_T$  in chapter " Calculation of the total deviation (according to DIN 16086)".

**Basic temperature error  $F_T$**

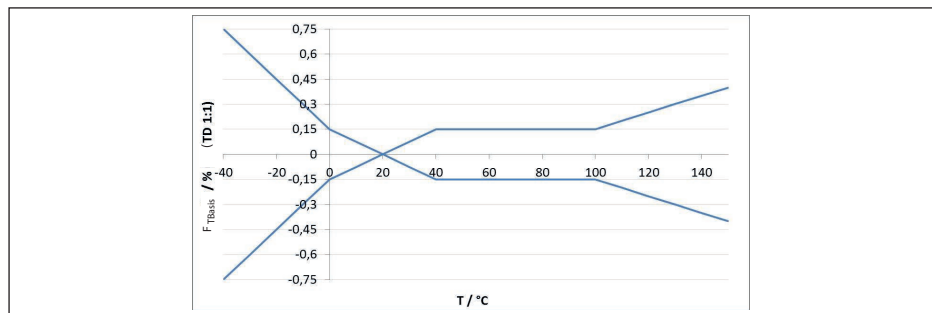

Fig. 36: Basic temperature error  $F_{TBasis}$  at TD 1 : 1

The basic temperature error in % from the above graphic can increase due to the additional factors, depending on the measuring cell version (factor FMZ) and the Turn Down (factor FTD). The additional factors are listed in the following tables.

**Additional factor through measuring cell version**

Measuring cell version	Measuring cell standard, depending on the accuracy class		
	0.05 %, 0.1 %	0.2 % (with measuring range 0.1 bar <sub>abs</sub> )	0.2 % 0.05 %, 0.1 % with measuring range 25 mbar
Factor FMZ	1	2	3

### Additional factor through Turn Down

The additional factor  $F_{TD}$  through Turn down is calculated according to the following formula:

$$F_{TD} = 0.5 \times TD + 0.5$$

In the table, example values for typical Turn downs are listed.

Turn Down	TD 1 : 1	TD 2.5 : 1	TD 5 : 1	TD 10 : 1	TD 20 : 1
Factor FTD	1	1.75	3	5.5	10.5

### Long-term stability (according to DIN 16086)

Applies to the respective **digital** signal output (e.g. HART, Profibus PA) as well as to **analogue** current output 4 ... 20 mA under reference conditions. Specifications refer to the set span. Turn down (TD) is the ratio nominal measuring range/set span.

### Long-term stability zero signal and output span

Time period	Measuring cell ø 28 mm		Measuring cell ø 17.5 mm
	Measuring ranges from 0 ... +0.1 bar (0 ... +10 kPa)	Measuring range 0 ... +0.025 bar (0 ... +2.5 kPa)	
One year	< 0.05 % x TD	< 0.1 % x TD	< 0.1 % x TD
Five years	< 0.1 % x TD	< 0.2 % x TD	< 0.2 % x TD
Ten years	< 0.2 % x TD	< 0.4 % x TD	< 0.4 % x TD

### Ambient conditions

Version	Ambient temperature	Storage and transport temperature
Standard version	-40 ... +80 °C (-40 ... +176 °F)	-60 ... +80 °C (-76 ... +176 °F)
Version IP66/IP68 (1 bar)	-20 ... +80 °C (-4 ... +176 °F)	-20 ... +80 °C (-4 ... +176 °F)
Version IP68 (25 bar), with connection cable PUR	-20 ... +80 °C (-4 ... +176 °F)	-20 ... +80 °C (-4 ... +176 °F)
Version IP68 (25 bar), connection cable PE	-20 ... +60 °C (-4 ... +140 °F)	-20 ... +60 °C (-4 ... +140 °F)

### Process conditions

#### Process temperature - Process fittings stainless steel

Measuring cell seal		Sensor version	
		Standard	Extended temperature range <sup>6)</sup>
FKM	VP2/A	-20 ... +130 °C (-4 ... +266 °F)	-20 ... +150 °C (-4 ... +302 °F)
	A+P 70.16	-40 ... +130 °C (-40 ... +266 °F)	-
	V70SW	-	-10 ... +150 °C (14 ... +302 °F)

<sup>6)</sup> Measuring cell ø 28 mm

Measuring cell seal		Sensor version	
		Standard	Extended temperature range <sup>6)</sup>
EPDM	A+P 70.10-02	-40 ... +130 °C (-40 ... +266 °F)	-40 ... +150 °C (-40 ... +302 °F)
	ET 7056	-40 ... +130 °C (-40 ... +266 °F)	-
	E70Q	-	-40 ... +150 °C (-40 ... +302 °F)
	Fluoraz SD890	-5 ... +130 °C (-22 ... +266 °F)	-
FFKM	Kalrez 6375	-20 ... +130 °C (-4 ... +266 °F)	-20 ... +150 °C (-4 ... +302 °F)
	Perlast G74S	-15 ... +130 °C (5 ... +266 °F)	-15 ... +150 °C (5 ... +302 °F)
	Perlast G75B	-15 ... +130 °C (5 ... +266 °F)	-15 ... +150 °C (5 ... +302 °F)
	Perlast G92E	-15 ... +130 °C (... +266 °F)	-15 ... +150 °C (5 ... +302 °F)
	Perlast G75LT	-40 ... +130 °C (-40 ... +266 °F)	-40 ... +150 °C (-40 ... +302 °F)

### Process temperature - Process fittings plastic

Measuring cell seal		Process temperature		
		Process fitting PEEK <sup>7)</sup>	Process fitting PP	Process fitting PVDF <sup>8)</sup>
FKM	VP2/A	-20 ... +100 °C (-4 ... +212 °F)	0 ... +100 °C (32 ... +212 °F)	-20 ... +80 °C (-4 ... +176 °F) <sup>9)</sup>
	A+P 70.16	-40 ... +100 °C (-40 ... +212 °F)		
EPDM	A+P 70.10-02			
FFKM	Kalrez 6375	-20 ... +100 °C (-4 ... +212 °F)		
	Perlast G74S	-15 ... +100 °C (5 ... +212 °F)		
	Perlast G75B			

### Temperature derating

<sup>6)</sup> Measuring cell ø 28 mm

<sup>7)</sup> Max. permissible process pressure depending on the process fitting 25 bar resp. 30 bar (siehe type label)

<sup>8)</sup> Max. permissible process pressure thread versions: 10 bar

<sup>9)</sup> Process pressures > 5 bar: 20 ... +60 °C (-4 ... +140 °F)

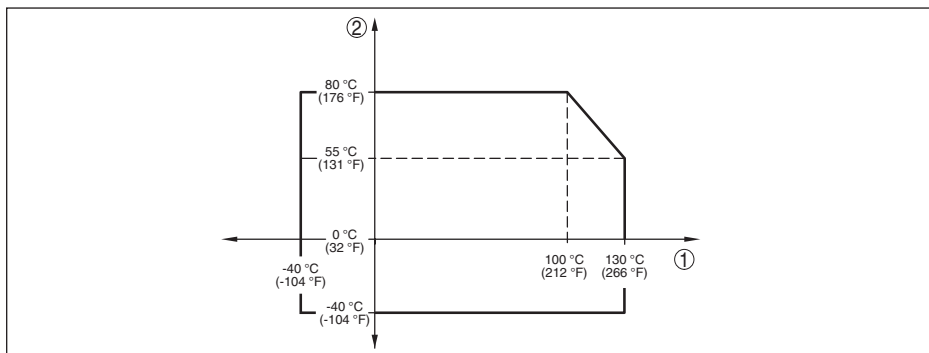

Fig. 37: Temperature derating CPT-2x, version up to +130 °C (+266 °F)

- 1 Process temperature
- 2 Ambient temperature

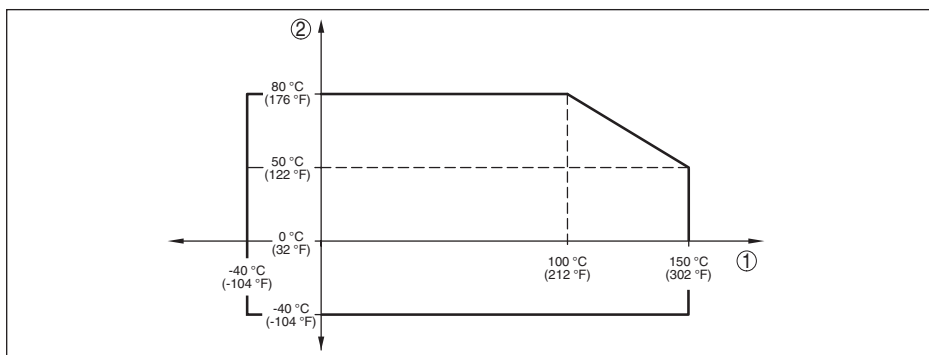

Fig. 38: Temperature derating CPT-2x, version up to +150 °C (+302 °F)

- 1 Process temperature
- 2 Ambient temperature

**SIP process temperature** (SIP = Sterilization in place)

Applies to instruments configurations suitable for vapour, i.e. material measuring cell seal EPDM or FFKM (Perlast G74S).

Vapour stratification up to 2 h +150 °C (+302 °F)

**Process pressure**

Permissible process pressure see specification " *process pressure*" on the type label

**Mechanical stress<sup>10)</sup>**

Vibration resistance 4 g at 5 ... 200 Hz according to EN 60068-2-6 (vibration with resonance)

Shock resistance 50 g, 2.3 ms according to EN 60068-2-27 (mechanical shock) <sup>11)</sup>

<sup>10)</sup> Depending on the instrument version.

<sup>11)</sup> 2 g with housing version stainless steel double chamber

**Electromechanical data - version IP66/IP67 and IP66/IP68 (0.2 bar) <sup>12)</sup>**

Options of the cable entry

- Cable entry M20 x 1.5; ½ NPT
- Cable gland M20 x 1.5; ½ NPT (cable ø see below table)
- Blind plug M20 x 1.5; ½ NPT
- Closing cap ½ NPT

Material cable gland/Seal insert	Cable diameter			
	5 ... 9 mm	6 ... 12 mm	7 ... 12 mm	10 ... 14 mm
PA/NBR	√	√	–	√
Brass, nickel-plated/NBR	√	√	–	–
Stainless steel/NBR	–	–	√	–

Wire cross-section (spring-loaded terminals)

- Massive wire, stranded wire 0.2 ... 2.5 mm<sup>2</sup> (AWG 24 ... 14)
- Stranded wire with end sleeve 0.2 ... 1.5 mm<sup>2</sup> (AWG 24 ... 16)

**Electromechanical data - version IP66/IP68 (1 bar)**

Connection cable, mechanical data

- Configuration Wires, strain relief, breather capillaries, screen braiding, metal foil, mantle
- Standard length 5 m (16.4 ft)
- Min. bending radius (at 25 °C/77 °F) 25 mm (0.984 in)
- Diameter approx. 8 mm (0.315 in)
- Colour - version PE Black
- Colour - version PUR Blue

Connection cable, electrical data

- Wire cross-section 0.5 mm<sup>2</sup> (AWG 20)
- Wire resistance R' 0.037 Ω/m (0.012 Ω/ft)

**Electromechanical data - version IP68 (25 bar)**

Connection cable transmitter - external housing, mechanical data

- Configuration Wires, strain relief, breather capillaries, screen braiding, metal foil, mantle <sup>13)</sup>
- Standard length 5 m (16.40 ft)
- Max. length 180 m (590.5 ft)
- Min. bending radius at 25 °C/77 °F 25 mm (0.985 in)
- Diameter approx. 8 mm (0.315 in)
- Material PE, PUR
- Colour Black, blue

<sup>12)</sup> IP66/IP68 (0.2 bar), only with absolute pressure.<sup>13)</sup> Breather capillaries not with Ex d version.

Connection cable transmitter - external housing, electrical data

- Wire cross-section 0.5 mm<sup>2</sup> (AWG 20)
- Wire resistance 0.037 Ω/m (0.012 Ω/ft)

**Display and adjustment module**

Display element	Display with backlight
Measured value indication	
- Number of digits	5
Adjustment elements	
- 4 keys	[OK], [->], [ + ], [ESC]
Protection rating	
- unassembled	IP20
- Mounted in the housing without lid	IP40
Materials	
- Housing	ABS
- Inspection window	Polyester foil
Functional safety	SIL non-reactive

**Interface to the external display and adjustment unit**

Data transmission	Digital (I <sup>2</sup> C-Bus)
Connection cable	Four-wire

Sensor version	Configuration, connection cable		
	Cable length	Standard cable	Shielded
4 ... 20 mA/HART Modbus	50 m	●	-
Profibus PA, Foundation Fieldbus	25 m	-	●

**Integrated clock**

Date format	Day.Month.Year
Time format	12 h/24 h
Time zone, factory setting	CET
Max. rate deviation	10.5 min/year

**Additional output parameter - Electronics temperature**

Range	-40 ... +85 °C (-40 ... +185 °F)
Resolution	< 0.1 K
Deviation	± 3 K
Availability of the temperature values	
- Indication	Via the display and adjustment module
- Output	Via the respective output signal

**Voltage supply**

Operating voltage $U_B$	9.6 ... 35 V DC
Operating voltage $U_B$ with lighting switched on	16 ... 35 V DC
Reverse voltage protection	Integrated
Permissible residual ripple	
– for $U_N$ 12 V DC ( $9.6 \text{ V} < U_B < 14 \text{ V}$ )	$\leq 0.7 V_{\text{eff}}$ (16 ... 400 Hz)
– for $U_N$ 24 V DC ( $18 \text{ V} < U_B < 35 \text{ V}$ )	$\leq 1.0 V_{\text{eff}}$ (16 ... 400 Hz)
Load resistor	
– Calculation	$(U_B - U_{\text{min}})/0.022 \text{ A}$
– Example - with $U_B = 24 \text{ V DC}$	$(24 \text{ V} - 9.6 \text{ V})/0.022 \text{ A} = 655 \Omega$

**Potential connections and electrical separating measures in the instrument**

Electronics	Non-floating
Galvanic separation	
– between electronics and metallic parts of the device	Reference voltage 500 V AC
Conductive connection	Between ground terminal and metallic process fitting

**Electrical protective measures <sup>14)</sup>**

Housing material	Version	Protection acc. to IEC 60529	Protection acc. to NEMA
Plastic	Single chamber	IP66/IP67	Type 4X
	Double chamber		
Aluminium	Single chamber	IP66/IP67 IP66/IP68 (0.2 bar) IP66/IP68 (1 bar)	Type 4X Type 6P Type 6P
	Double chamber	IP66/IP67 IP66/IP68 (0.2 bar)	Type 4X Type 6P
Stainless steel (electro-polished)	Single chamber	IP66/IP67 IP69K	Type 4X
Stainless steel (precision casting)	Single chamber	IP66/IP67 IP66/IP68 (0.2 bar) IP66/IP68 (1 bar)	Type 4X Type 6P Type 6P
	Double chamber	IP66/IP67 IP66/IP68 (0.2 bar)	Type 4X Type 6P
Stainless steel	Transmitter, version with external housing	IP68 (25 bar)	-

Connection of the feeding power supply unit Networks of overvoltage category III

<sup>14)</sup> Protection rating IP66/IP68 (0.2 bar) only in conjunction with absolute pressure, as no air compensation is possible when the sensor is completely flooded

Altitude above sea level

- by default up to 2000 m (6562 ft)
  - with connected overvoltage protection up to 5000 m (16404 ft)
- Pollution degree <sup>15)</sup> 2
- Protection rating (IEC/EN 61010-1) II

## 9.2 Communication Profibus PA

In the following, the necessary device-specific details are shown. You can find further information of Profibus PA on [www.profibus.com](http://www.profibus.com).

### Instrument master file

The instrument master file (GSD) contains the characteristic data of the Profibus PA instrument. These data are, e.g. the permissible transmission rates as well as information on diagnostics values and the format of the measured value output by the PA instrument.

A bitmap file is also provided for the Profibus network planning tool. This file is installed automatically when the GSD file is integrated. The bitmap file is used for symbolic indication of the PA instrument in the configuration tool.

### ID number

Each Profibus instrument gets an unambiguous ident number (ID number) from the Profibus user organisation (PNO). This ID number is also included in the name of the GSD file. Optionally in addition to this manufacturer-specific GSD file, PNO also provides a general so-called profile-specific GSD file. If the general GSD file is used, the sensor must be set to the profile-specific ident number via the DTM software. By default, the sensor operates with the manufacturer-specific ID number. When using the instruments on a segment coupler SK-2 or SK-3, no special GSD files are required.

The following table shows the instrument ID and the GSD file names.

Instrument ID		GSD file name	
WIKA	Instrument class in profile 3.02	WIKA	Profile-specific
0F93 HEX	0x9702	WI0x6b0F93.GSD	PA139760.GSD (Multi_Variable)

### Cyclical data traffic

The Primary class 1 (e.g. PLC) cyclically reads out measured values from the sensor during operation. The below block diagram below shows which data can be accessed by the PLC.

<sup>15)</sup> When used with fulfilled housing protection.



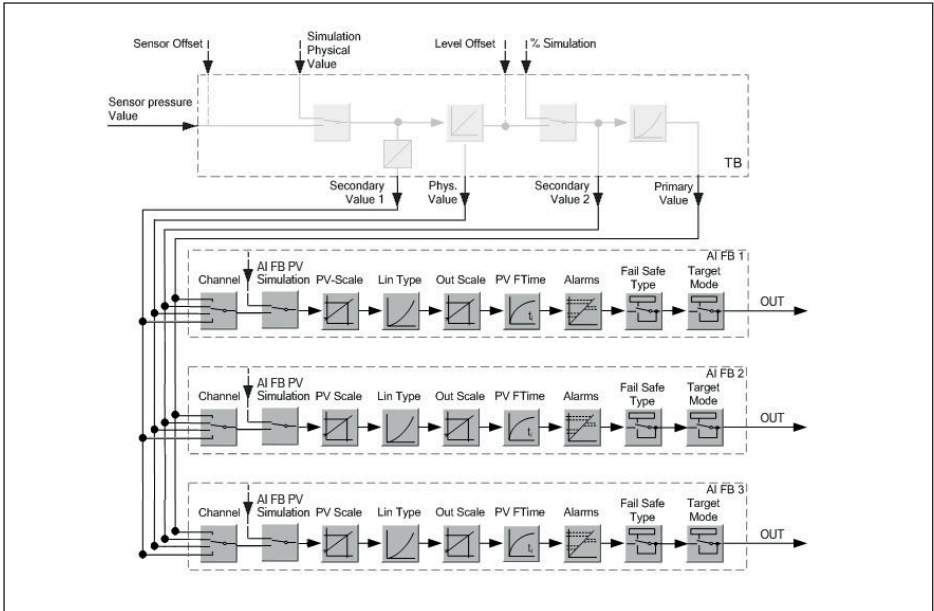

Fig. 39: CPT-2x: Block diagram with AI FB 1 ... AI FB 3 OUT values

TB Transducer Block

FB Function Block

AI Analogue Input

## Module of the PA sensors

For the cyclic data traffic, CPT-2x provides the following modules:

- AI FB1 (OUT)
  - Out value of the AI FB1 after scaling
- AI FB2 (OUT)
  - Out value of the AI FB2 after scaling
- AI FB3 (OUT)
  - Out value of the AI FB3 after scaling
- Free Place
  - This module must be used if a value in the data telegram of the cyclical data traffic should not be used (e.g. replacement of temperature and Additional Cyclic Value)

A maximum of three modules can be active. By means of the configuration software of the Profibus master you can determine the configuration of the cyclical data telegram with these modules. The procedure depends on the respective configuration software.



### Note:

The modules are available in two versions:

- Short for Profibus master supporting only one "Identifier Format" byte, e.g. Allen Bradley
- Long for Profibus master only supporting the "Identifier Format" byte, e.g. Siemens S7-300/400

## Examples of telegram configuration

In the following you will see how the modules can be combined and how the appendant data telegram is structured.

### Example 1

- AI FB1 (OUT)
- AI FB2 (OUT)
- AI FB3 (OUT)

Byte-No.	1	2	3	4	5	6	7	8	9	10	11	12	13	14	15
Format	IEEE-754-Floating point value				Status	IEEE-754-Floating point value				Status	IEEE-754-Floating point value				Status
Value	AI FB1 (OUT)				AI FB1	AI FB2 (OUT)				AI FB2	AI FB3 (OUT)				AI FB3

### Example 2

- AI FB1 (OUT)
- Free Place
- Free Place

Byte-No.	1	2	3	4	5
Format	IEEE-754-Floating point value				Status
Value	AI FB1 (OUT)				AI FB1



#### Note:

Bytes 6-15 are not used in this example.

## Data format of the output signal

Byte4	Byte3	Byte2	Byte1	Byte0
Status	Value (IEEE-754)			

Fig. 40: Data format of the output signal

The status byte corresponds to profile 3.02 "Profibus PA Profile for Process Control Devices" coded. The status "Measured value OK" is coded as 80 (hex) (Bit7 = 1, Bit6 ... 0 = 0).

The measured value is transferred as a 32 bit floating point number in the IEEE-754 format.

Byte n								Byte n+1								Byte n+2								Byte n+3							
Bit 7	Bit 6	Bit 5	Bit 4	Bit 3	Bit 2	Bit 1	Bit 0	Bit 7	Bit 6	Bit 5	Bit 4	Bit 3	Bit 2	Bit 1	Bit 0	Bit 7	Bit 6	Bit 5	Bit 4	Bit 3	Bit 2	Bit 1	Bit 0	Bit 7	Bit 6	Bit 5	Bit 4	Bit 3	Bit 2	Bit 1	Bit 0
VZ	2 <sup>7</sup>	2 <sup>6</sup>	2 <sup>5</sup>	2 <sup>4</sup>	2 <sup>3</sup>	2 <sup>2</sup>	2 <sup>1</sup>	2 <sup>0</sup>	2 <sup>1</sup>	2 <sup>2</sup>	2 <sup>3</sup>	2 <sup>4</sup>	2 <sup>5</sup>	2 <sup>6</sup>	2 <sup>7</sup>	2 <sup>-8</sup>	2 <sup>-9</sup>	2 <sup>-10</sup>	2 <sup>-11</sup>	2 <sup>-12</sup>	2 <sup>-13</sup>	2 <sup>-14</sup>	2 <sup>-15</sup>	2 <sup>-16</sup>	2 <sup>-17</sup>	2 <sup>-18</sup>	2 <sup>-19</sup>	2 <sup>-20</sup>	2 <sup>-21</sup>	2 <sup>-22</sup>	2 <sup>-23</sup>
Sign Bit	Exponent							Significant							Significant							Significant									

$$\text{Value} = (-1)^{VZ} \cdot 2^{(\text{Exponent} - 127)} \cdot (1 + \text{Significant})$$

Fig. 41: Data format of the measured value

## Coding of the status byte associated with the PA output value

You can find further information for the coding of the status byte in the Device Description 3.02 on [www.profibus.com](http://www.profibus.com).

Status code	Description according to Profibus standard	Possible cause
0 x 00	bad - non-specific	Flash-Update active
0 x 04	bad - configuration error	<ul style="list-style-type: none"> <li>● Adjustment error</li> <li>● Configuration error with PV-Scale (PV-Span too small)</li> <li>● Unit irregularity</li> <li>● Error in the linearization table</li> </ul>
0 x 0C	bad - sensor failure	<ul style="list-style-type: none"> <li>● Hardware error</li> <li>● Converter error</li> <li>● Leakage pulse error</li> <li>● Trigger error</li> </ul>
0 x 10	bad - sensor failure	<ul style="list-style-type: none"> <li>● Measured value generation error</li> <li>● Temperature measurement error</li> </ul>
0 x 1f	bad - out of service constant	"Out of Service" mode switched on
0 x 44	uncertain - last unstable value	Failsafe replacement value (Failsafe-Mode = "Last value" and already valid measured value since switching on)
0 x 48	uncertain substitute set	<ul style="list-style-type: none"> <li>● Switch on simulation</li> <li>● Failsafe replacement value (Failsafe-Mode = "Fsafe value")</li> </ul>
0 x 4c	uncertain - initial value	Failsafe replacement value (Failsafe-Mode = "Last valid value" and no valid measured value since switching on)
0 x 51	uncertain - sensor; conversion not accurate - low limited	Sensor value < lower limit
0 x 52	uncertain - sensor; conversion not accurate - high limited	Sensor value > upper limit
0 x 80	good (non-cascade) - OK	OK
0 x 84	good (non-cascade) - active block alarm	Static revision (FB, TB) changed (10 sec. active, after the parameter of the static category has been written)
0 x 89	good (non-cascade) - active advisory alarm - low limited	Lo-Alarm
0 x 8a	good (non-cascade) - active advisory alarm - high limited	Hi-Alarm
0 x 8d	good (non-cascade) - active critical alarm - low limited	Lo-Lo-Alarm
0 x 8e	good (non-cascade) - active critical alarm - high limited	Hi-Hi-Alarm

### 9.3 Calculation of the total deviation

The total deviation of a pressure transmitter indicates the maximum measurement error to be expected in practice. It is also called maximum practical deviation or operational error.

According to DIN 16086, the total deviation  $F_{\text{total}}$  is the sum of the basic deviation  $F_{\text{perf}}$  and the long-term stability  $F_{\text{stab}}$ :

$$F_{\text{total}} = F_{\text{perf}} + F_{\text{stab}}$$

The basic deviation  $F_{\text{perf}}$  in turn consists of the thermal change of the zero signal and the output span  $F_T$  (temperature error) as well as the deviation  $F_{K1}$ :

$$F_{\text{perf}} = \sqrt{(F_T)^2 + (F_{K1})^2}$$

The thermal change of zero signal and output span  $F_T$  is specified in chapter " *Technical data*". The basic temperature error  $F_T$  is shown in a graphic. Depending on the measuring cell version and Turn down, this value must be multiplied with the additional factors FMZ and FTD:

$$F_T \times \text{FMZ} \times \text{FTD}$$

Also these values are specified in chapter " *Technical data*".

This applies initially to the digital signal output through HART, Profibus PA, Foundation Fieldbus or Modbus.

With 4 ... 20 mA output, the thermal change of the current output  $F_a$  must be added:

$$F_{\text{perf}} = \sqrt{(F_T)^2 + (F_{K1})^2 + (F_a)^2}$$

To provide a better overview, the formula symbols are listed together below:

- $F_{\text{total}}$ : Total deviation
- $F_{\text{perf}}$ : Basic deviation
- $F_{\text{stab}}$ : Long-term stability
- $F_T$ : Thermal change of zero signal and output span (temperature error)
- $F_{K1}$ : Deviation
- $F_a$ : Thermal change of the current output
- FMZ: Additional factor measuring cell version
- FTD: Additional factor Turn down

### 9.4 Calculation of the total deviation - Practical example

#### Data

Pressure measurement in the pipeline 4 bar (400 KPa)

Product temperature up to 50 °C

CPT-2x with measuring range 10 bar, deviation < 0.2 %, process fitting G1½ (measuring cell ø 28 mm)

#### 1. Calculation of the Turn down

TD = 10 bar/4 bar, TD = **2.5 : 1**

## 2. Determination temperature error $F_T$

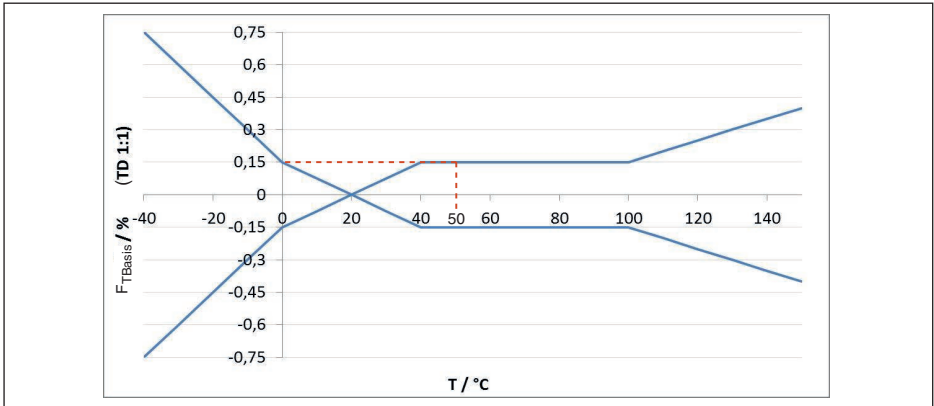

Fig. 42: Determination of the basic temperature error for the above example:  $F_{TBasis} = 0.15\%$

Measuring cell version	Measuring cell standard, depending on the accuracy class		
	0.05 %, 0.1 %	0.2 % (0.1 bar <sub>abs</sub> )	0.2 %
Factor FMZ	1	2	3

Tab. 22: Determination of the additional factor measuring cell for above example:  $F_{MZ} = 3$

Turn Down	TD 1 : 1	TD 2.5 : 1	TD 5 : 1	TD 10 : 1	TD 20 : 1
Factor FTD	1	1.75	3	5.5	10.5

Tab. 23: Determination of the additional factor "turn down" for the above example:  $F_{TD} = 1.75$

$$F_T = F_{TBasis} \times F_{MZ} \times F_{TD}$$

$$F_T = 0.15\% \times 3 \times 1.75$$

$$F_T = 0.79\%$$

## 3. Determination of deviation and long-term stability

The required values for deviation  $F_{KI}$  and long-term stability  $F_{stab}$  are available in the technical data:

Accuracy class	Non-linearity, hysteresis and non-repeatability	
	TD ≤ 5 : 1	TD > 5 : 1
0.05 %	< 0.05 %	< 0.01 % x TD
0.1 %	< 0.1 %	< 0.02 % x TD
0.2 %	< 0.2 %	< 0.04 % x TD

Tab. 24: Determination of the deviation from table:  $F_{KI} = 0.2\%$

Time period	Measuring cell ø 28 mm		Measuring cell ø 17.5 mm	
	All measuring ranges	Measuring range 0 ... +0.025 bar (0 ... +2.5 kPa)	All process fittings	Process fitting G½ (ISO 228-1)
One year	< 0.05 % x TD	< 0.1 % x TD	< 0.1 % x TD	< 0.25 % x TD
Five years	< 0.1 % x TD	< 0.2 % x TD	< 0.2 % x TD	< 0.5 % x TD
Ten years	< 0.2 % x TD	< 0.4 % x TD	< 0.4 % x TD	< 1 % x TD

Tab. 25: Determination of the long-term stability from the table, consideration for one year:  $F_{stab} = 0.05 \% \times TD$

#### 4. Calculation of the total deviation - digital signal outputs

##### 1. step: Basic deviation $F_{perf}$

$$F_{perf} = \sqrt{((F_T)^2 + (F_{KI})^2)}$$

$$F_T = 0.79 \%$$

$$F_{KI} = 0.2 \%$$

$$F_{perf} = \sqrt{(0.79 \%)^2 + (0.2 \%)^2}$$

$$F_{perf} = 0.81 \%$$

##### 2. step: Total deviation $F_{total}$

$$F_{total} = F_{perf} + F_{stab}$$

$$F_{perf} = 0.81 \% \text{ (result of step 1)}$$

$$F_{stab} = (0.05 \% \times TD)$$

$$F_{stab} = (0.05 \% \times 2.5)$$

$$F_{stab} = 0.125 \%$$

$$F_{total} = 0.81 \% + 0.125 \% = 0.94 \%$$

The total deviation of the measurement is hence 0.94 %.

Deviation in bar: 0.94 % of 4 bar = 0.038 bar

The example shows that the measurement error in practice can be considerably higher than the basic deviation. Reasons are temperature influence and Turn down.

## 9.5 Dimensions

### Plastic housing

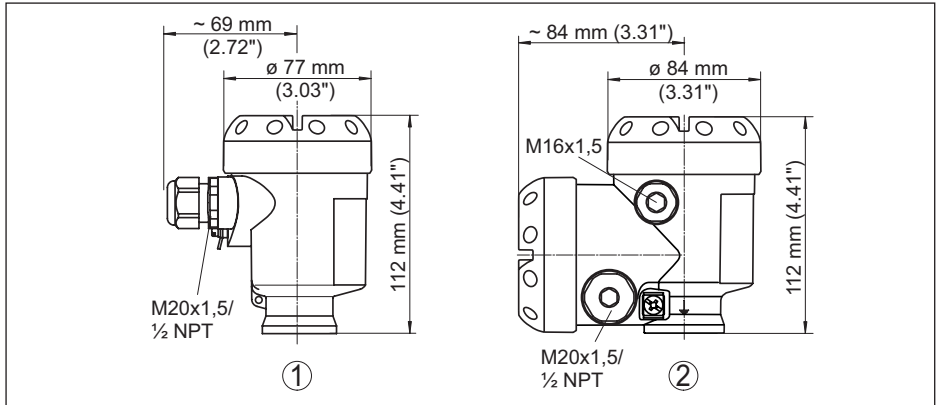

Fig. 43: Housing versions in protection IP66/IP67 (with integrated display and adjustment module the housing is 9 mm/0.35 in higher)

- 1 Plastic single chamber
- 2 Plastic double chamber

### Aluminium housing

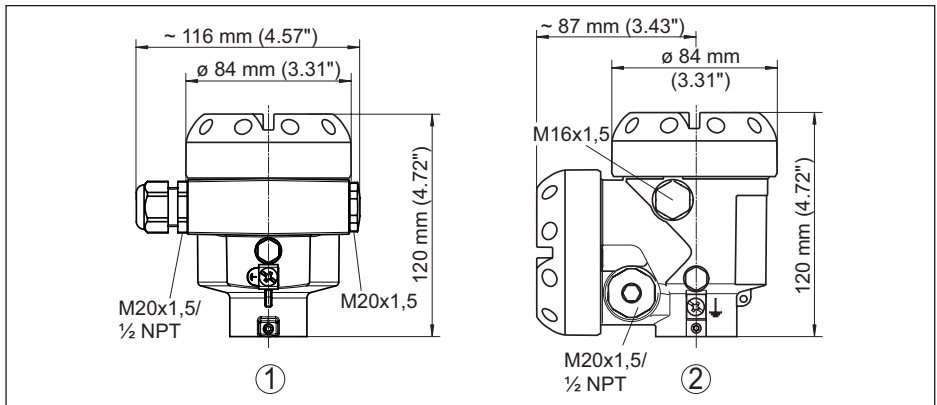

Fig. 44: Housing versions in protection IP66/IP67 (with integrated display and adjustment module the housing is 9 mm/0.35 in higher)

- 1 Aluminium - single chamber
- 2 Aluminium - double chamber

### Aluminium housing with protection rating IP66/IP68 (1 bar)

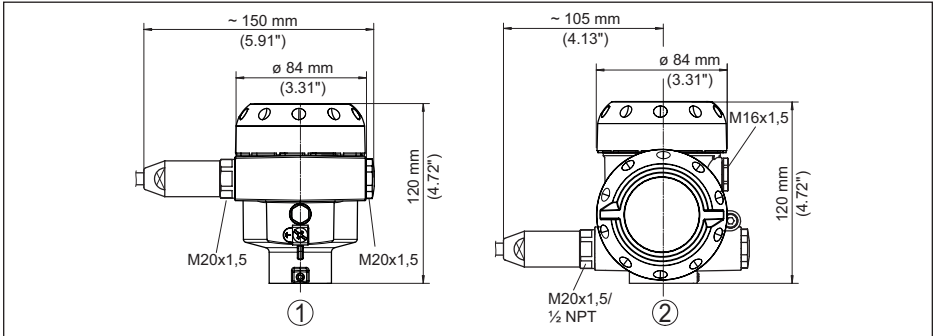

Fig. 45: Housing version with protection rating IP66/IP68 (1 bar), (with integrated display and adjustment module the housing is 9 mm/0.35 in higher)

- 1 Aluminium - single chamber
- 2 Aluminium - double chamber

### Stainless steel housing

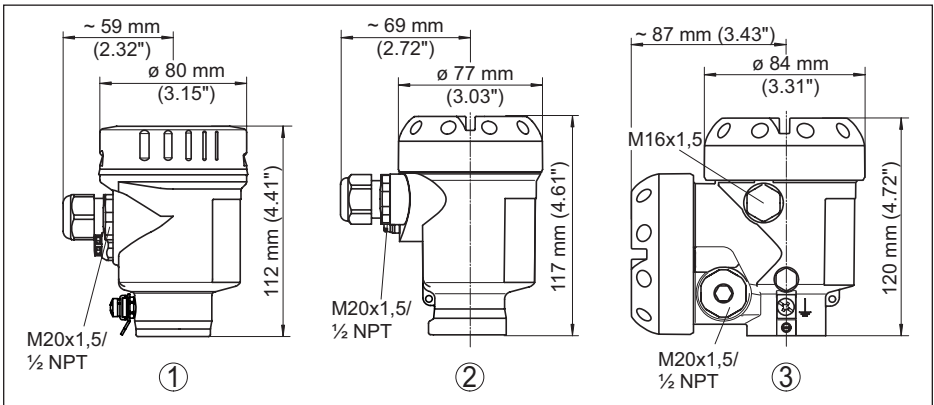

Fig. 46: Housing versions in protection IP66/IP67 (with integrated display and adjustment module the housing is 9 mm/0.35 in higher)

- 1 Stainless steel single chamber (electropolished)
- 2 Stainless steel single chamber (precision casting)
- 3 Stainless steel double chamber (precision casting)



**Stainless steel housing with protection rating IP66/IP68 (1 bar)**

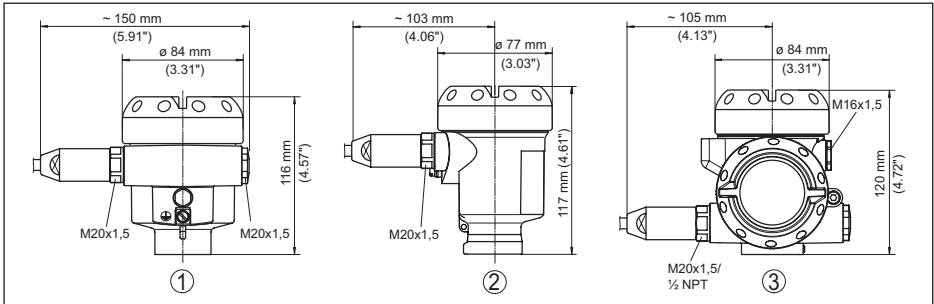

Fig. 47: Housing version with protection rating IP66/IP68 (1 bar), (with integrated display and adjustment module the housing is 9 mm/0.35 in higher)

- 1 Stainless steel single chamber (electropolished)
- 2 Stainless steel single chamber (precision casting)
- 3 Stainless steel double chamber (precision casting)

**Stainless steel housing with protection rating IP69K**

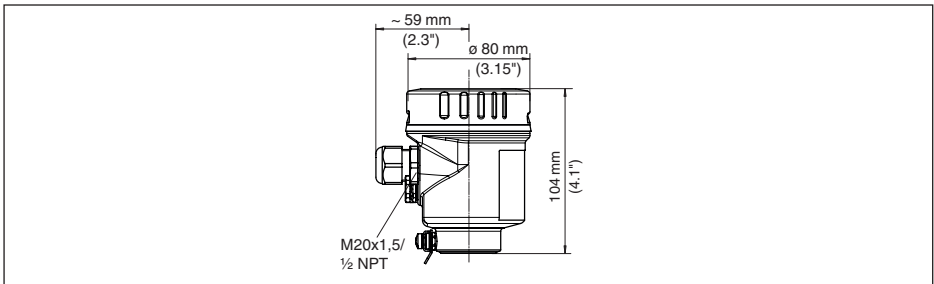

Fig. 48: Housing version with protection rating IP69K (with integrated display and adjustment module the housing is 9 mm/0.35 in higher)

- 1 Stainless steel single chamber (electropolished)

External housing with IP68 (25 bar) version

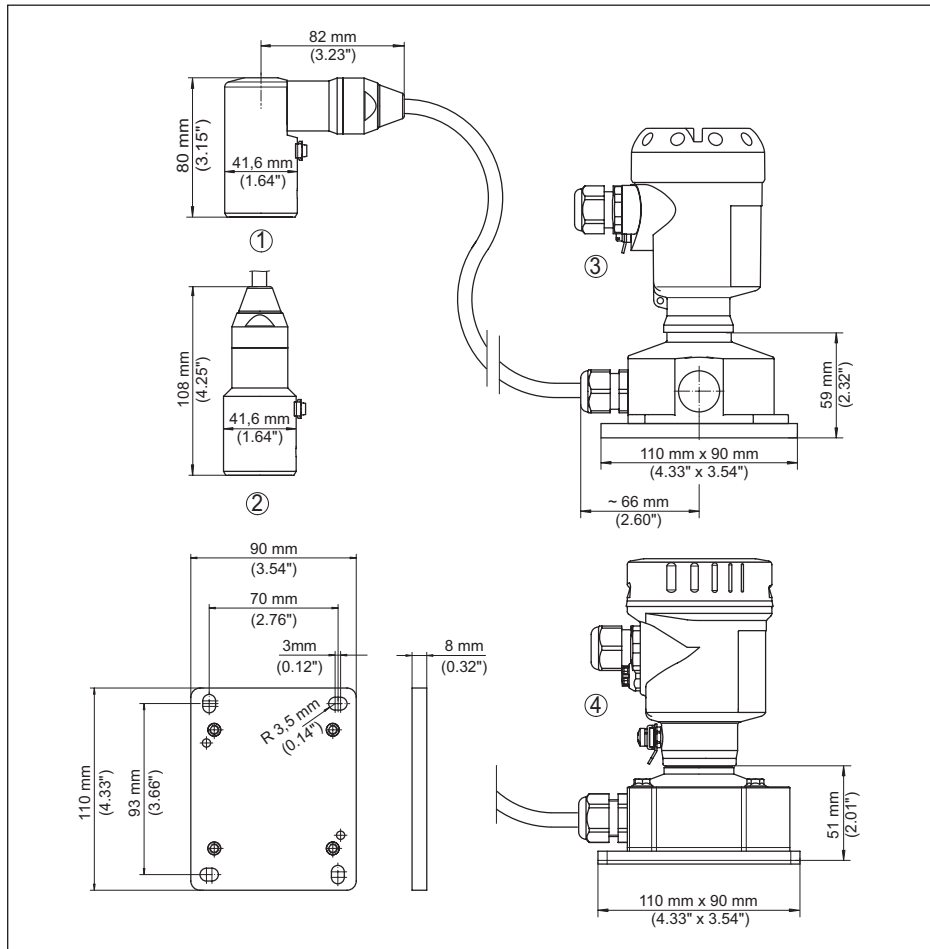

Fig. 49: IP68 version with external housing

- 1 Lateral cable outlet
- 2 Cable outlet axial
- 3 Plastic housing
- 4 Stainless steel housing, electropolished

## CPT-2x, threaded fitting not front-flush

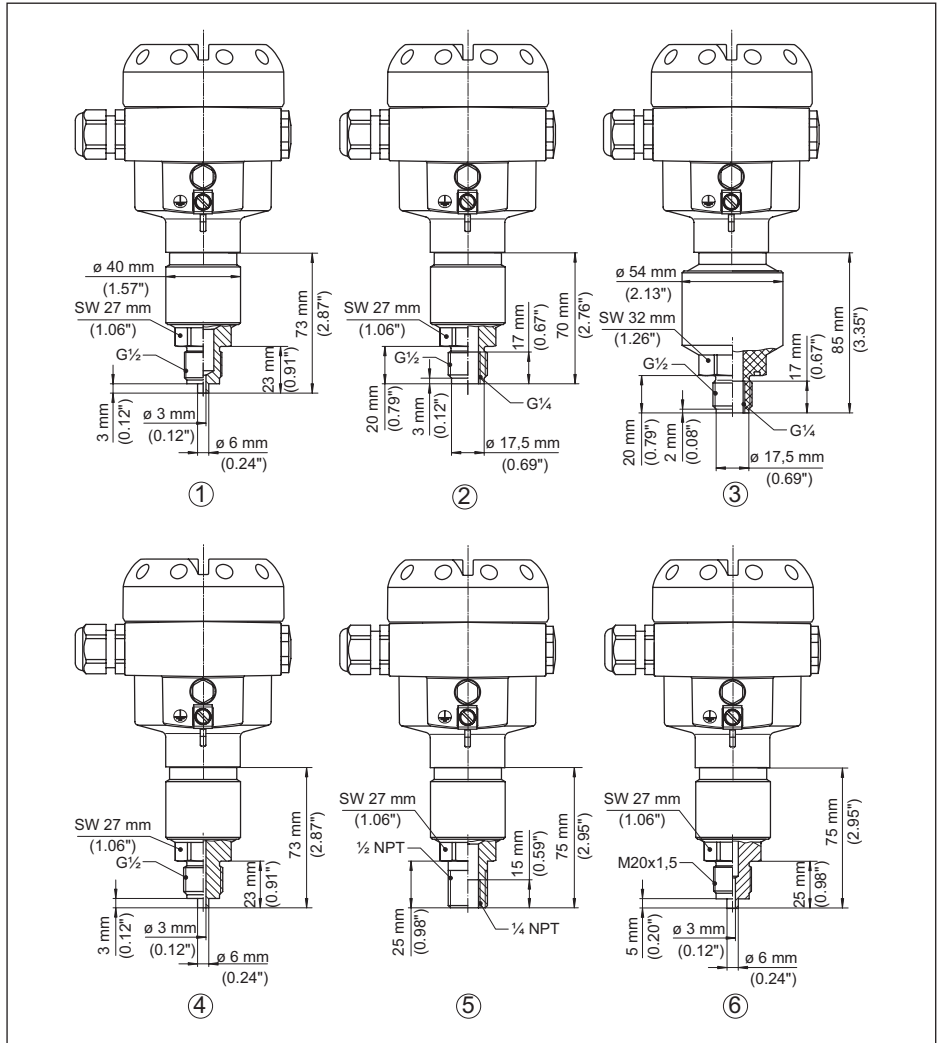

Fig. 50: CPT-2x, threaded fitting not front-flush

- 1  $G\frac{1}{2}$  (EN 837); manometer connection 316L/PEEK
- 2  $G\frac{1}{2}$ , inside  $G\frac{1}{4}$  (ISO 228-1)
- 3  $G\frac{1}{2}$ , inner  $G\frac{1}{4}$  A (ISO 228-1), PVDF
- 4  $G\frac{1}{2}$  (EN 837); manometer connection volume-reduced
- 5  $\frac{1}{2}$  NPT, inside  $\frac{1}{4}$  NPT
- 6 M20 x 1.5 (EN 837); manometer connection

**Notes:**

For the version with "Second Line of Defense", the measure of length increases by 17 mm (0.67 in).

## CPT-2x, threaded fitting front-flush

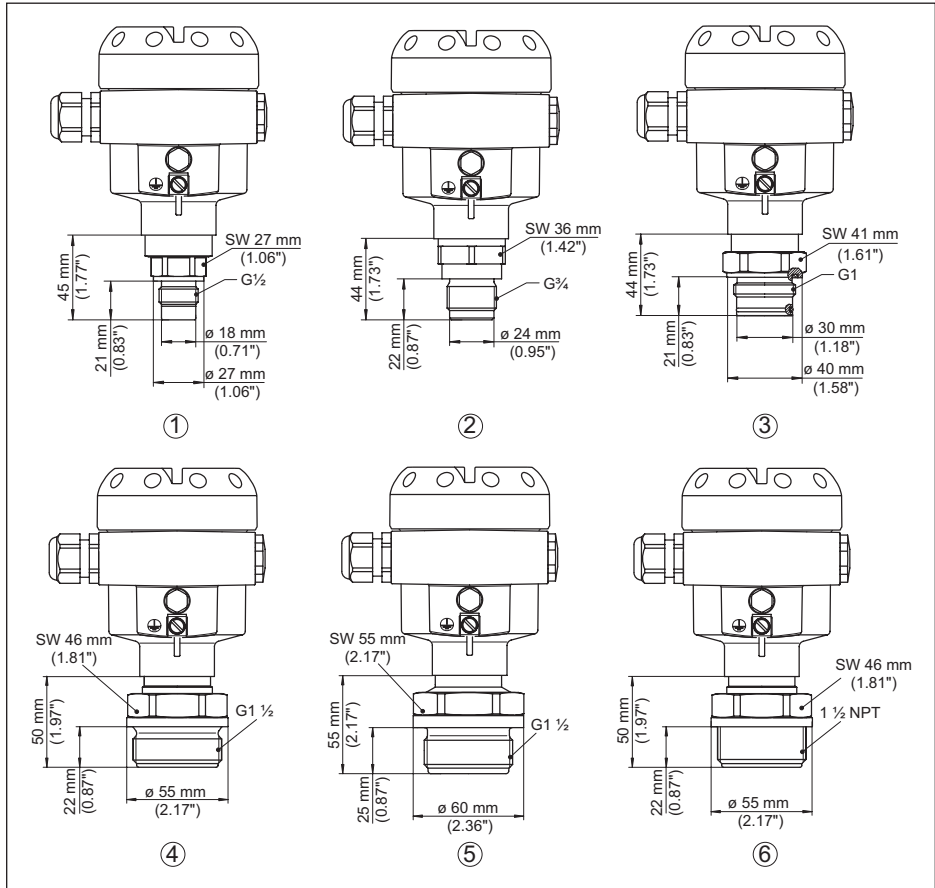

Fig. 51: CPT-2x, threaded fitting front-flush

- 1  $G\frac{1}{2}$  (ISO 228-1)
- 2  $G\frac{3}{4}$  (DIN 3852-E)
- 3  $G1$  (ISO 228-1)
- 4  $G1\frac{1}{2}$  (DIN 3852-A)
- 5  $G1\frac{1}{2}$  (DIN 3852-A-B); PVDF
- 6  $1\frac{1}{2}$  NPT (ASME B1.20.1)

For the version with temperature range up to  $+150\text{ }^{\circ}\text{C}$  ( $+302\text{ }^{\circ}\text{F}$ ), the measure of length increases by 28 mm (1.1 in).

For the version with "Second Line of Defense", the measure of length increases by 17 mm (0.67 in).

## CPT-2x, hygienic fitting

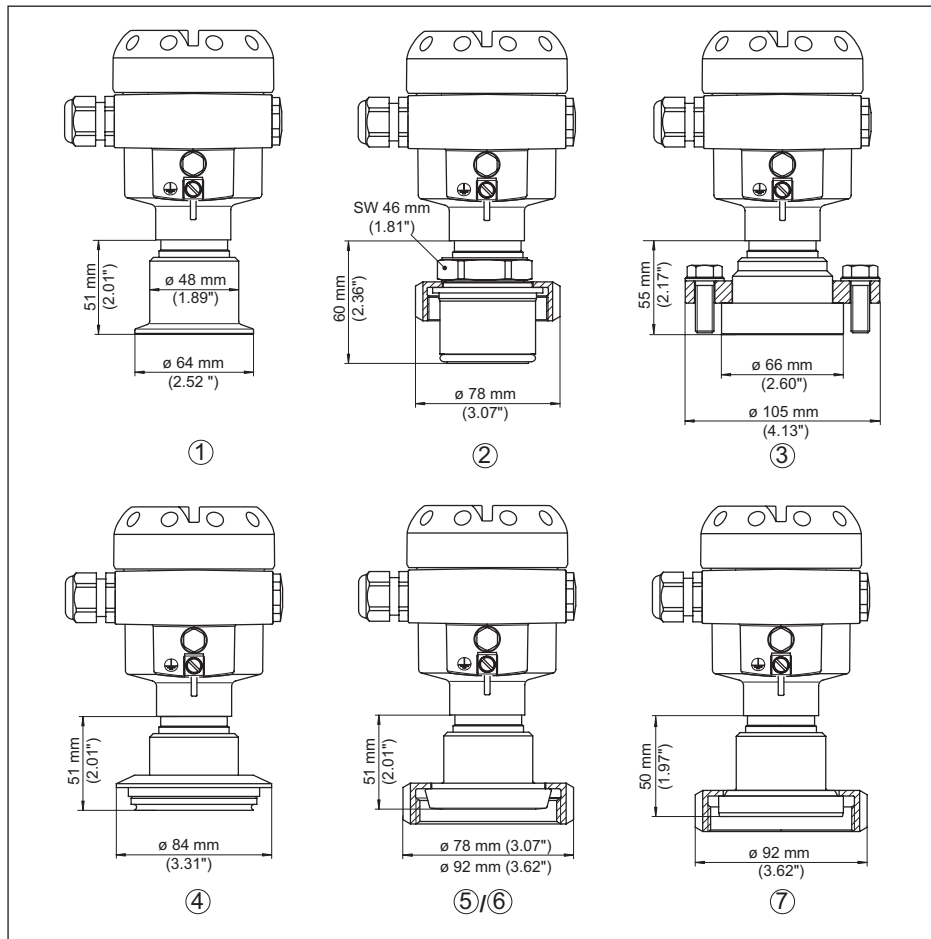

Fig. 52: CPT-2x, hygienic fitting

- 1 Clamp 2"
- 2 Hygienic connection with compression nut F40
- 3 DRD
- 4 Varivent DN 32
- 5 Slotted nut DN 40 (DIN 11851)
- 6 Slotted nut DN 50 (DIN 11851)
- 7 Slotted nut DN 50 (DIN 11864-1)

For the version with temperature range up to +150 °C (+302 °F), the measure of length increases by 28 mm (1.1 in).

For the version with "Second Line of Defense", the measure of length increases by 17 mm (0.67 in).

## CPT-2x, flange connection

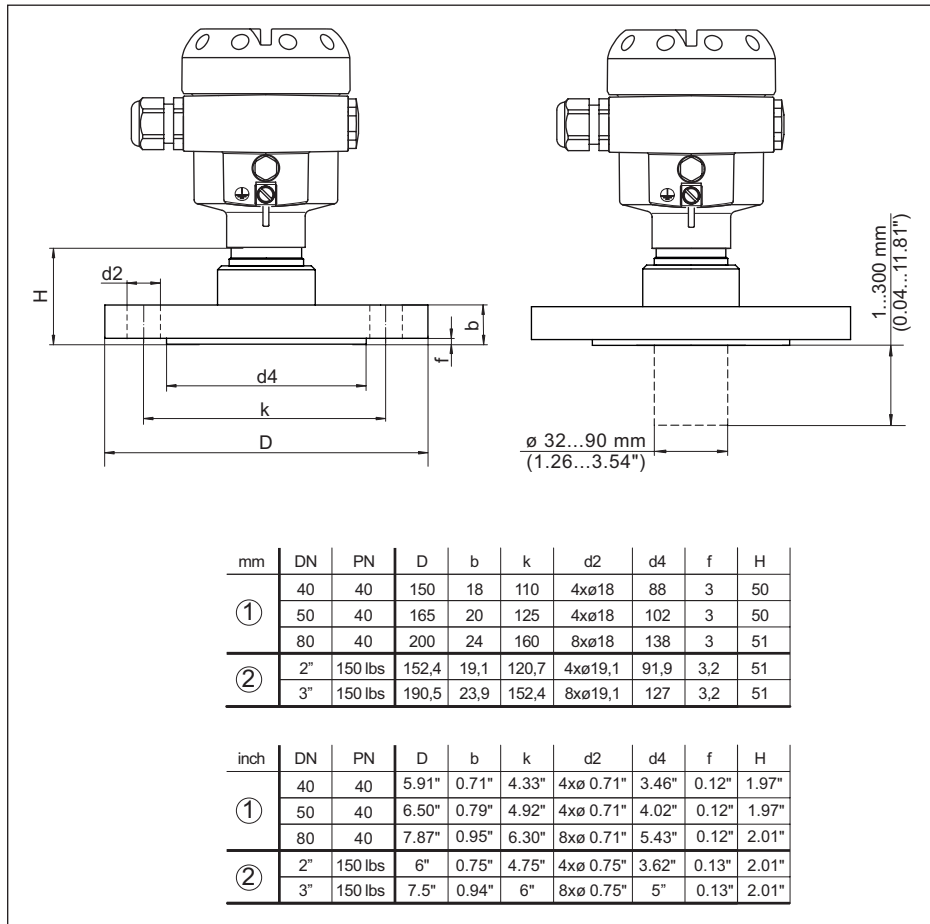

Fig. 53: CPT-2x, flange connection

- 1 Flange connection according to DIN 2501
- 2 Flange connection according to ASME B16.5

For the version with temperature range up to +150 °C (+302 °F), the measure of length increases by 28 mm (1.1 in).

For the version with "Second Line of Defense", the measure of length increases by 17 mm (0.67 in).

## CPT-2x, extension fitting

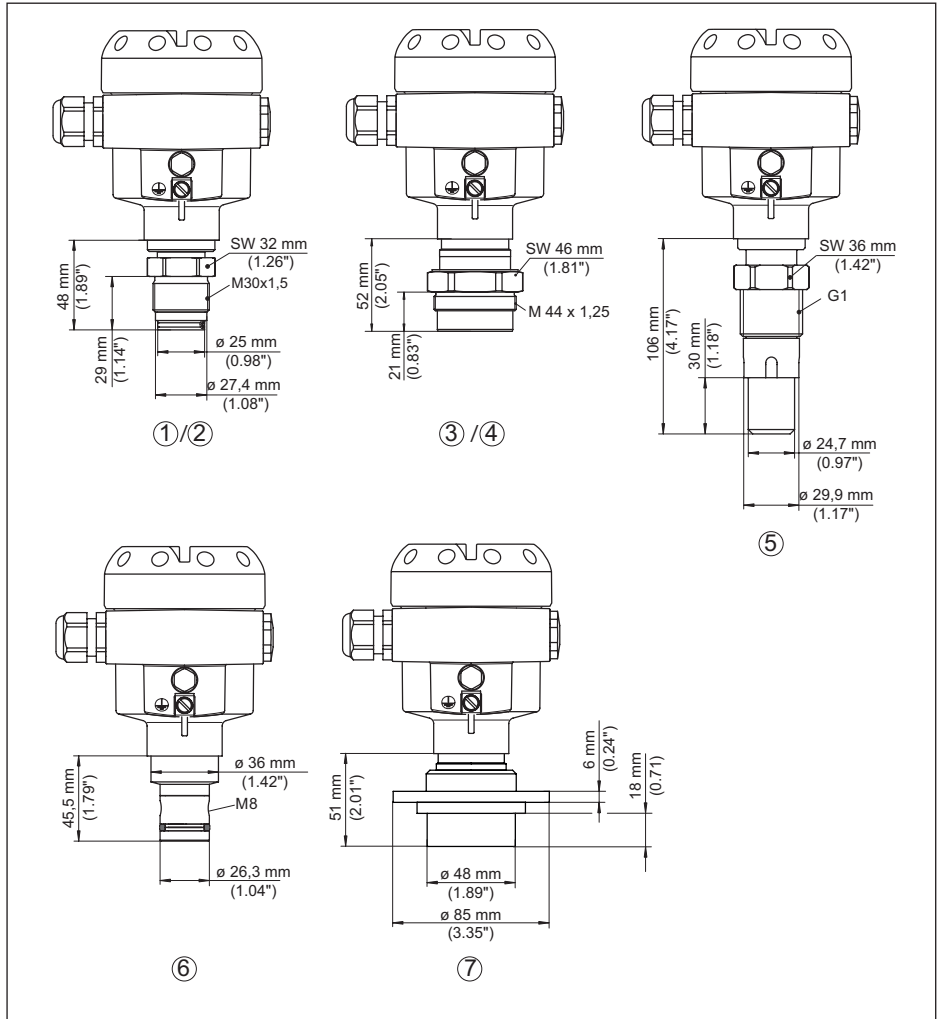

Fig. 54: CPT-2x, extension fitting

- 1 M30 x 1.5 (DIN 13); completely front-flush
- 2 M30 x 1.5 (DIN 13); for headbox
- 3 M44 x 1.25 (DIN 13); pressure screw: Aluminium
- 4 M44 x 1.25 (DIN 13); pressure screw: 316L
- 5 G1 (ISO 228-1) suitable for PASVE
- 6 PMC 1" front-flush PN 6
- 7 DN 48 with tension flange

For the version with temperature range up to +150 °C (+302 °F), the measure of length increases by 28 mm (1.1 in).

For the version with "Second Line of Defense", the measure of length increases by 17 mm (0.67 in).

## CPT-2x, connection acc. to IEC 61518

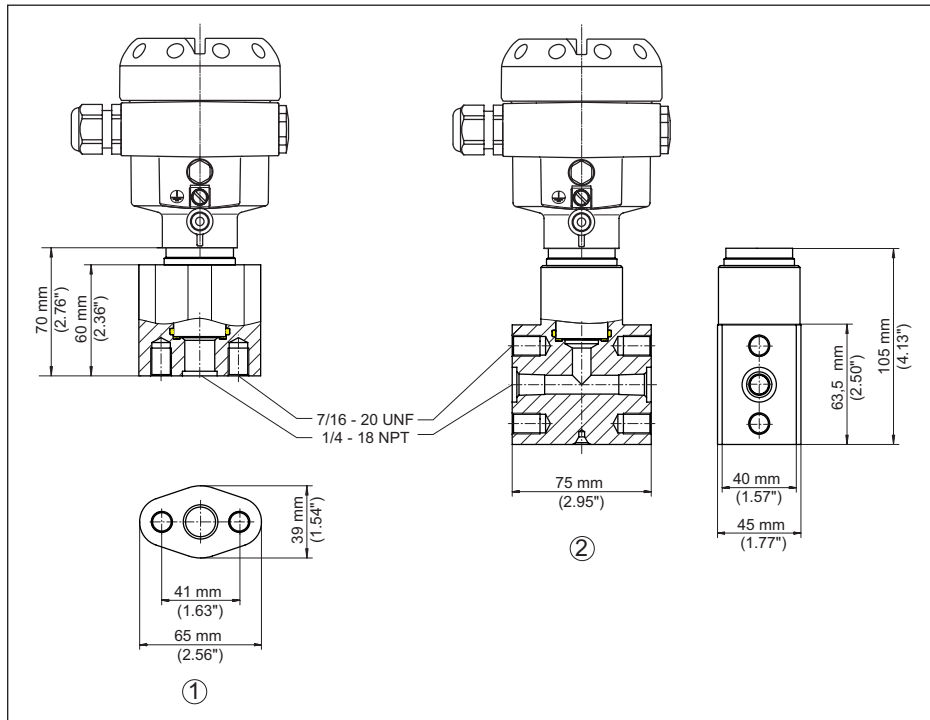

Fig. 55: CPT-2x, connection acc. to IEC 61518

- 1 Oval flange adapter
- 2 Top flange

For the version with temperature range up to +150 °C (+302 °F), the measure of length increases by 28 mm (1.1 in).

For the version with "Second Line of Defense", the measure of length increases by 17 mm (0.67 in).



## 9.6 Trademark

All the brands as well as trade and company names used are property of their lawful proprietor/originator.

## INDEX

### A

- Adjust Date/Time 39
- Adjustment 35
  - Process pressure 34
  - System 29
  - Unit 32
- AI FB1 Function Block 36

### C

- Change the language 37
- Channel 36
- Copy sensor settings 40
- Cyclical data traffic 64

### D

- Damping 37
- Data format, output signal 66
- Display lighting 38
- Documentation 7

### E

- Electrical connection 21
- Error codes 46, 47

### F

- Fault
  - Rectification 48
- Fault rectification 48

### G

- GSD file 64

### H

- Hardware addressing 31

### I

- Instrument address 31
- Instrument master file 64

### L

- Linearisation 36

### M

- Main menu 30
- Maintenance 43
- Measured value memory 44
- Measurement setup 17, 18, 19

### N

- NAMUR NE 107 45

### O

- Oxygen applications 15

### P

- PA modules 65
- Parameterization example 33
- Peak indicator 38, 39
- Position correction 32
- Pressure compensation 16, 17
  - Ex d 16
  - Standard 15
- Process pressure measurement 17

### Q

- QR code 7

### R

- Reset 39

### S

- Scaling 36
- Scaling unit 36
- Seal concept 9
- Serial number 7
- Service access 40
- Set display parameters 38
- Simulation 39
- Software addressing 31
- Status bytes PA output value 67

### T

- Telegram configuration 66
- Type label 7

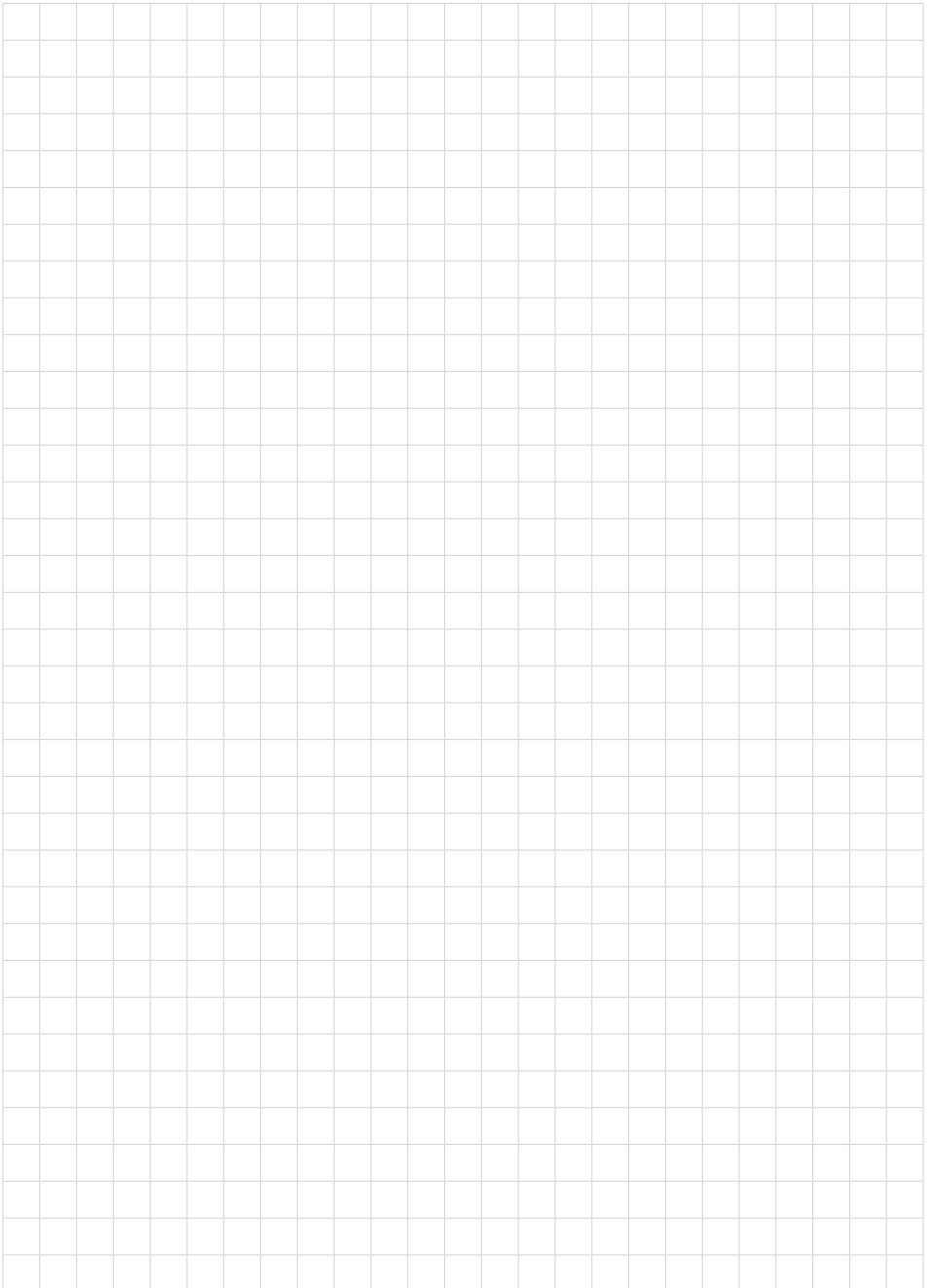

Printing date:

All statements concerning scope of delivery, application, practical use and operating conditions of the sensors and processing systems correspond to the information available at the time of printing.



**WIKAI Alexander Wiegand SE & Co. KG**  
Alexander-Wiegand-Straße 30  
63911 Klingenberg  
Germany  
Phone (+49) 9372/132-0  
E-mail: [info@wika.de](mailto:info@wika.de)  
[www.wika.de](http://www.wika.de)

52751-EN-230914