



Model PCS 400M

This Manual contains important information.
PLEASE READ PRIOR TO USE.

WARRANTY

All products manufactured by Mensor[®] Corporation are warranted to be free of defects in workmanship and materials for a period of one year from the date of shipment. No other express warranty is given, and no affirmation of Seller, by words or actions, shall constitute a warranty. SELLER DISCLAIMS ANY IMPLIED WARRANTIES OF MERCHANTABILITY OR FITNESS FOR ANY PARTICULAR PURPOSES WHATSOEVER. If any defect in workmanship or material should develop under conditions of normal use and service within the warranty period, repairs will be made at no charge to the original purchaser, upon delivery of the product(s) to the factory, shipping charges prepaid. If inspection by Mensor Corporation or its authorized representative reveals that the product was damaged by accident, alteration, misuse, abuse, faulty installation or other causes beyond the control of Mensor Corporation, this warranty does not apply. The judgment of Mensor Corporation will be final as to all matters concerning condition of the product, the cause and nature of a defect, and the necessity or manner of repair. Service, repairs or disassembly of the product in any manner, performed without specific factory permission, voids this warranty.

MENSOR CORPORATION MAKES NO WARRANTY OF ANY KIND WITH REGARD TO THIS MANUAL, INCLUDING, BUT NOT LIMITED TO, THE IMPLIED WARRANTIES OF MERCHANTABILITY AND FITNESS FOR A PARTICULAR PURPOSE. Mensor Corporation shall not be liable for errors contained herein or for incidental or consequential damages in connection with the furnishing, performance, or use of this material.

WARNINGS AND CAUTION NOTES**WARNING: HIGH PRESSURE!**

High pressure gases are potentially hazardous. Energy stored in these gases can be released suddenly and with extreme force. High pressure systems should be assembled and operated only by personnel who have been trained in proper safety practices.

**WARNING: HIGH SOUND LEVELS!**

Pressures from 600 psig and up can generate sound levels above 100 db for brief periods when they are exhausted directly to atmosphere. If no muffling devices are attached to the EXHAUST port, then ear protection is advised for personnel in the vicinity of instruments that will be operated under such conditions.

**WARNING: NOT EXPLOSION PROOF!**

Installation of this instrument in an area requiring devices rated as intrinsically safe is not recommended.

**WARNING: POSSIBLE INJURY!**

The tubing, valves and other apparatus attached to the gauge must be adequate for the maximum pressure which will be applied, otherwise physical injury to the operator or bystanders is possible.



CAUTION: USE THE PROPER PRESSURE MEDIUM. USE ONLY CLEAN, DRY NON-CORROSIVE GASES UNLESS OTHERWISE SPECIFIED BY MENSOR. THIS INSTRUMENT IS NOT DESIGNED FOR OXYGEN USE.



CAUTION: ESD PROTECTION REQUIRED. The proper use of grounded work surfaces and personal wrist straps are required when coming into contact with exposed circuits (printed circuit boards) to prevent static discharge to sensitive electronic components.

IMPORTANT NOTE

Please Notice: The product specifications and other information contained in this manual are subject to change without notice. Mensor Corporation has made a concerted effort to provide complete and current information for the proper use of the equipment. If there are questions regarding this manual or the proper use of the equipment, contact Mensor Corporation at:

TEL	1.512.396.4200 or 1.800.984.4200 (USA only)
FAX	1.512.396.1820
WEB SITE	www.mensor.com
E-MAIL	sales@mensor.com
	tech.support@mensor.com
	quality@mensor.com

PACKAGING FOR SHIPMENT

If the product must be shipped to a different location or returned to Mensor for any reason through a common carrier it must be packaged properly to minimize the risk of damage.

The recommended method of packing is to place the instrument in a container, surrounded on all sides with at least four inches of shock attenuation material such as styrofoam peanuts.

SOFTWARE LICENSE AGREEMENT

This product contains intellectual property, i.e., software programs, that are licensed for use by the end user/customer (hereinafter "end user").

This is not a sale of such intellectual property.

The end user shall not copy, disassemble or reverse compile the software program.

THE SOFTWARE PROGRAMS ARE PROVIDED TO THE END USER "AS IS" WITHOUT WARRANTY OF ANY KIND, EITHER EXPRESS OR IMPLIED, INCLUDING, BUT NOT LIMITED TO, WARRANTIES OF MERCHANTABILITY AND FITNESS FOR A PARTICULAR PURPOSE. THE ENTIRE RISK OF THE QUALITY AND PERFORMANCE OF THE SOFTWARE PROGRAM IS WITH THE END USER.

MENSOR AND ITS SUPPLIERS SHALL NOT BE HELD TO ANY LIABILITY FOR ANY DAMAGES SUFFERED OR INCURRED BY THE END USER (INCLUDING, BUT NOT LIMITED TO, GENERAL, SPECIAL, CONSEQUENTIAL OR INCIDENTAL DAMAGES INCLUDING DAMAGES FOR LOSS OF BUSINESS PROFITS, BUSINESS INTERRUPTION, LOSS OF BUSINESS INFORMATION AND THE LIKE), ARISING FROM OR IN CONNECTION WITH THE DELIVERY, USE OR PERFORMANCE OF THE SOFTWARE PROGRAM.

FCC RADIO FREQUENCY EMISSION NOTICE

This equipment has been tested and found to comply with the limits for a Class A digital device, pursuant to Part 15 of the FCC Rules. These limits are designed to provide reasonable protection against harmful interference when the equipment is operated in a commercial environment. This equipment generates, uses, and can radiate radio frequency energy and, if not installed and used in accordance with the instruction manual, may cause harmful interference to radio communications. Operation of this equipment in a residential area is likely to cause harmful interference in which case the user will be required to correct the interference at his or her own expense.

USE SHIELDED CABLES TO CONNECT EXTERNAL DEVICES TO THIS INSTRUMENT TO MINIMIZE RF RADIATION.

TRADEMARKS

Mensor is a registered trademark of Mensor Corporation. All other brand and product names are trademarks or registered trademarks of their respective companies. The PCS 400M instrument contains software licensed from Microsoft Corporation.

©2005, Mensor Corp. All rights reserved.

MENSOR BACKGROUND

HISTORY: Mensor is an ISO-9001:2000 certified manufacturer of precision pressure products. Mensor was established in 1969 in Houston, Texas as an independent spin-off from the Texas Instruments (TI) Pressure Instrument Group. As a private corporation, Mensor's objective was to design and produce high accuracy, high quality, easy to use pressure instruments. In 1978 Mensor moved to its present location in San Marcos, on Interstate 35 (the Austin-San Antonio corridor). Two and a half years after the move, the plant was destroyed by fire on Friday, February 13, 1981. Mensor resolved to come back, and almost before the ashes had cooled, construction of a new building began on the same site. Six months after the disaster, Mensor moved into its present facility and began shipping products to customers who had waited patiently for the recovery.

PEOPLE: The key to Mensor's strength in the marketplace is the concentration of experienced people in the field of precision pressure measurement and control. The company's founders previously worked in various capacities in the Pressure Instrument Group of Texas Instruments, including engineering, production and marketing. These founders were involved in the design of the original quartz bourdon pressure gauge at TI. Mensor's CEO, Jerry Fruit, is co-holder of the patent on using a fused quartz bourdon tube to accurately measure pressure. Mensor employees have an average longevity of sixteen years. That's a lot of pressure experience!

PRODUCTS: Mensor's portfolio of products consists of an extensive line of precision pressure instruments, including digital gauges, pressure controllers, transducers and pressure calibrations systems. All of these products feature computer interface capability. These products are used in metrology labs, calibration labs, research facilities, engineering offices, production test stands, and in other environments where high accuracy pressure measurement and/or control is required. Many of these products include customized features to meet a customer's specific requirement. Mensor products range from about \$900 to \$30,000.

CUSTOMERS: Typical Mensor customers are pressure sensor manufacturers, aerospace firms, jet engine manufacturers, electric utilities, nuclear power plants, pharmaceutical firms, calibration laboratories, government agencies and research organizations.

APPLICATIONS: In many facilities the highest accuracy pressure measuring or pressure controlling instrument is a Mensor product. A typical application for these Mensor instruments is the calibration of other pressure devices, such as sensors, transducers, transmitters, gauges and pressure switches. The Mensor product is used as the pressure standard to verify pressure calibrations or outputs of the device being produced, checked, tested or certified.



SUMMARY OF CONTENTS

This manual includes the sections listed below.

- 1 **INTRODUCTION** lists the items that are shipped with a standard instrument, provides a brief overview of the instrument, and gives advice on an initial power-up.
- 2 **INSTALLATION** states the mounting options, defines the pressure connections, and gives examples of the initialization screens.
- 3 **LOCAL OPERATION** is a walk-thru of the display, keypads, transducers, modes of operation and includes a complete menu tree.
- 4 **REMOTE OPERATION** explains communicating with an external computer; includes the commands available over the IEEE-488-STD bus, or via the RS-232 serial port.
- 5 **MAINTENANCE** shows how to resolve some commonly encountered functional questions, and contains a list of available spare parts.
- 6 **CALIBRATION** defines the recommended calibration intervals. Provides separate procedures for calibrating either absolute or gauge type instruments.
- 7 **SPECIFICATIONS** lists the specifications for a standard instrument. Special or optional features may include overriding specifications either in Section 8, *Options*, or as an addendum to this manual.
- 8 **OPTIONS** includes a functional description of the various options available as of this printing. Also includes additional specifications and remote commands for some of these options.
- 9 **APPENDIX** contains a number of useful tables, figures, pneumatic schematics and additional information.
- 10 **INDEX** lists keywords arranged alphabetically and provides text locations.

COVER POCKET

This pocket holds a large, fold-out Menu Tree and a Quick Reference Card containing several items of useful information.

MENSOR IS ON THE WEB AT www.mensor.com

At our web site you will find information and specifications on Mensor's products and services. From there you can ask questions, or direct comments to our sales or technical people. Also available are various technical papers relating to pressure management which you can browse, download or convert to hard copy.

TABLE OF CONTENTS

Warranty	ii
Warnings and Caution Notes	iii
Please Notice	iii
Packaging for Shipment	iv
Software License Agreement	iv
FCC Radio Frequency Emission Notice	iv
Trademarks	iv
Mensor Background	v
Summary of Contents	vi

INTRODUCTION

Did you get everything?	1-1
Initial Inspection	1-1
Meet your Model PCS 400M	1-1
Front Panel	1-1
Rear Panel	1-2
Electrical Module	1-2
Pneumatic Module	1-3
Chassis Assembly	1-4
Summary of PCS 400M Functions	1-5
Power Up!	1-6
Mensor Service Plus	1-6
Calibration Services	1-6
Accreditations	1-6

INSTALLATION

Mounting	2-1
Pressure Connections	2-1
SUPPLY Pressure Port	2-1
EXHAUST Pressure Port	2-1
MEASURE/CONTROL Pressure Port	2-1
REFERENCE Pressure Port	2-1
Power On	2-2
System Checkout	2-2
Control Pressure Check	2-2

LOCAL OPERATION

Display	3-1
Keypad	3-1
Numeric Entry	3-1
Mode Entry	3-1
Menu Operations	3-2
Mode Functions	3-2
Default Values	3-6
Transducer	3-6
Address	3-6
Active Transducer	3-7
MEASURE Mode	3-7
Autorange	3-7

Control Modes	3-8
NORMAL Mode	3-8
RATE Mode	3-8
Multiple Transducers	3-8
Setup for Control Mode	3-9
Input a Control Point Value	3-9
Incrementing the Control Point	3-9
Regulator Response	3-9
Manual Valves Test	3-9
Dual Passwords	3-10
PCS 400M Menu Tree	3-11

REMOTE OPERATION

Device Dependent Messages	4-1
IEEE-488-STD (GPIB)	4-1
IEEE Capability Codes	4-1
Device Address	4-1
Service Request	4-1
Local Lockout	4-1
Status Display	4-1
GPIB Interface Messages	4-1
PCS 400M Command Set	4-2
Definitions	4-2
Commands	4-3
Tests	4-4
Queries	4-4
PCS 400M Command Responses	4-6
Error Codes	4-7
PCS 200 Emulation	4-9
Command Set	4-9
Emulation Responses	4-10
Command Reference	4-11
Changing the Mode of Operations	4-11
RS-232 Serial Communication	4-15
Cable Requirements	4-15
Setup	4-15
Parameters	4-15
Command Examples	4-15

MAINTENANCE

Beyond the Warranty	5-1
Program Disk Replacement	5-1
Module Replacement	5-1
Electrical Module	5-1
Troubleshooting Guide	5-2
Error Symptoms and Solutions	5-3
Spare Parts List	5-6

CALIBRATION

Calibration Environment	6-1
Pressure Standard	6-1
Calibration Medium	6-1

Calibration Procedures 6-1
 Calibrating a Gauge Pressure Instrument 6-2
 Setting the Sensor Zero 6-2
 Setting the Sensor Span 6-2
 Calibrating an Absolute Pressure Instrument 6-3
 Setting the Sensor Zero 6-3
 Setting the Sensor Span 6-4

SPECIFICATIONS

Measure Specifications 7-1
 Control Specifications 7-1
 General Specifications 7-2

OPTIONS

1 - Rack Mount Kit 8-2
 2 - Transport Case 8-4
 3 - Multiple Range Pneumatics Kit 8-5
 3a - Barometric Reference Transducer 8-5
 4 - Bi-Directional Pressure Control 8-6
 5 - Pressure Emulation Modes 8-6
 5a - Gauge Transducers (Absolute Emulation) without BRT 8-6
 5b - Gauge Transducers (Absolute and Vacuum Emulation) with BRT 8-7
 5c - Absolute Transducers (Gauge Emulation) with BRT 8-7
 6 - Low Pressure External Plumbing 8-9

APPENDIX

Measurement Units - Unitno (Table 9.1) 9-1
 Conversion Factors, PSI (Table 9.2) 9-2
 Conversion Factors, Pascal (Table 9.3) 9-3
 Temperature Conversion (Table 9.4) 9-4
 Solenoid Valve Truth Table (Table 9.5) 9-5
 Head Pressure Correction 9-6
 Gas Density (Table 9.6) 9-6
 Liquid Density (Table 9.7) 9-6
 Head Pressure Calculation (Figure 9.1) 9-7
 Sample Program 9-8
 Common Remote Commands (Table 9.8) 9-10
 Pneumatic Schematic - Standard PCS 400M (Figure 9.2) 9-11
 Pneumatic Schematic - Dual Range PCS 400M (Figure 9.3) 9-12
 Pneumatic Schematic - Dual Range Pressure with BRT (Figure 9.4) 9-13
 Pneumatic Schematic - Dual Absolute Pressure with BRT (Figure 9.5) 9-14
 Pneumatic Schematic - Two Independent Transducers (Figure 9.6) 9-15
 PCS 400M Sequence Program Script 9-16

INDEX 10-1

REFERENCE LIST OF FIGURES AND TABLES**Figures:**

Figure 1.1 – Front Panel	1-1
Figure 1.2 – PCS 400M - Rear View	1-2
Figure 1.3 – Internal Electrical Module - Top View	1-2
Figure 1.4 – Pneumatic Module - Top View	1-3
Figure 1.5 – Chassis Assembly - Top View	1-4
Figure 3.1 – Keypad	3-1
Figure 3.2 – PCS 400M Menu Tree	3-11
Figure 4.1 – Single Drop Cable	4-15
Figure 5.1 – Chassis Assembly - Top View	5-2
Figure 6.1 – Calibration Setup for Gauge Pressure	6-2
Figure 6.2 – Calibration Setup for Absolute Pressure	6-3
Figure 7.1 – Dimensional Outline	7-3
Figure 8.1 – Rack Mount Dimensions	8-2
Figure 8.2 – Rack Specifications	8-3
Figure 8.3 – Slide Specifications	8-3
Figure 8.4 – Transport Case	8-4
Figure 8.5 – Pneumatic Connections for Low Pressure External Plumbing	8-9
Figure 8.6 – Pneumatic Module for Low Pressure	8-10
Figure 9.1 – Head Pressure Calculation	9-7
Figure 9.2 – Pneumatic Schematic-Standard PCS 400M	9-11
Figure 9.3 – Pneumatic Schematic-Dual Range PCS 400M	9-12
Figure 9.4 – Pneumatic Schematic-Dual Gauge Pressure with BRT	9-13
Figure 9.5 – Pneumatic Schematic-Dual Absolute Pressure with BRT	9-14
Figure 9.6 – Pneumatic Schematic-Two Independent Transducers	9-15

Tables:

Table 3.1 – Default Values	3-6
Table 3.2 – Min/Max Rate	3-8
Table 4.1 – Valid Output Format	4-6
Table 4.2 – Error Codes	4-7 - 4-8
Table 4.3 – Emulation Responses	4-10
Table 4.4 – Data Bits Format	4-15
Table 5.1 – Error Symptoms and Solutions	5-3 - 5-5
Table 5.2 – Spare Parts	5-6
Table 7.1 – Minimum/Maximum Slew Speed	7-2
Table 8.1 – Transducer Type/Effect	8-8
Table 8.2 – Absolute Transducer Type/Effect	8-8
Table 9.1 – Measurement Units (unitno)	9-1
Table 9.2 – Conversion Factors, PSI	9-2
Table 9.3 – Conversion Factors, Pascal	9-3
Table 9.4 – Temperature Conversion Chart	9-4
Table 9.5 – Solenoid Valve Truth Table	9-5
Table 9.6 – Gas Density	9-6
Table 9.7 – Liquid Density	9-6
Table 9.8 – Common Remote Commands	9-10

INTRODUCTION

DID YOU GET EVERYTHING?

In addition to this manual you should have:

- PCS 400M
- Power cord
- Four 1/8 inch NPT fitting adapters
- Any accessories ordered
- An envelope containing a Calibration Certificate

INITIAL INSPECTION

Your new Mensor instrument was thoroughly tested and inspected at the factory, and it was free of dings, dents and scratches when it was packaged for shipment. Please examine it now for signs of shipping damage. Report any apparent damage to the carrier immediately.

MEET YOUR MODEL PCS 400M

The Model PCS 400M Pressure Calibration System is a self-contained, computerized, high accuracy pressure management system integrated into a single, compact unit. The system is comprised of a front panel assembly, a rear panel, an electrical module, a pneumatic module, and a chassis to tie it all together. The system functions either as a bench-top or a rack mounted instrument. It can operate in local mode to accept front panel input, or in remote mode to communicate with external devices. A brief description of the major elements of the system follows.

Front Panel

The front panel (figure 1.1) includes a forty character per line, two line display, a four by four membrane keypad, and a transparent window for the pressure range label. The keypad includes fifteen dual-function keys, plus a sixteenth key, labeled 2nd, which toggles the function of the other fifteen. All sixteen keys provide both tactile and audible feedback.

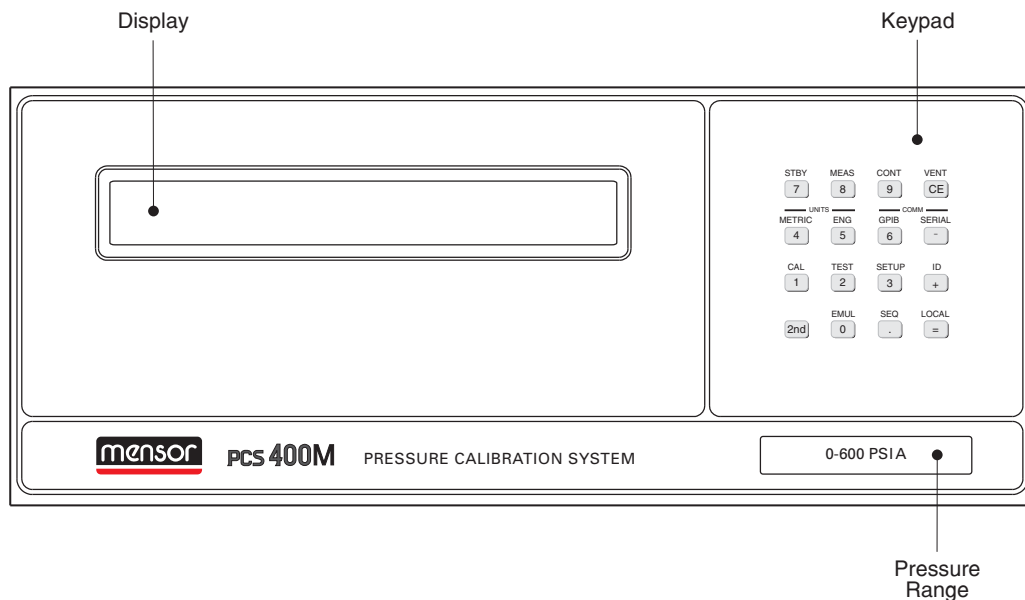

Figure 1.1 - Front Panel

Rear Panel

The rear panel (figure 1.2) includes access to the line-fuse holder, the power cord socket, the system power switch, a ventilator fan opening, and several communication connectors. All of these items are grouped on the electrical module side of the rear

panel. The pneumatic side exposes the four fitting ports of the pressure manifold, and may have additional electrical connectors to support optional functions.

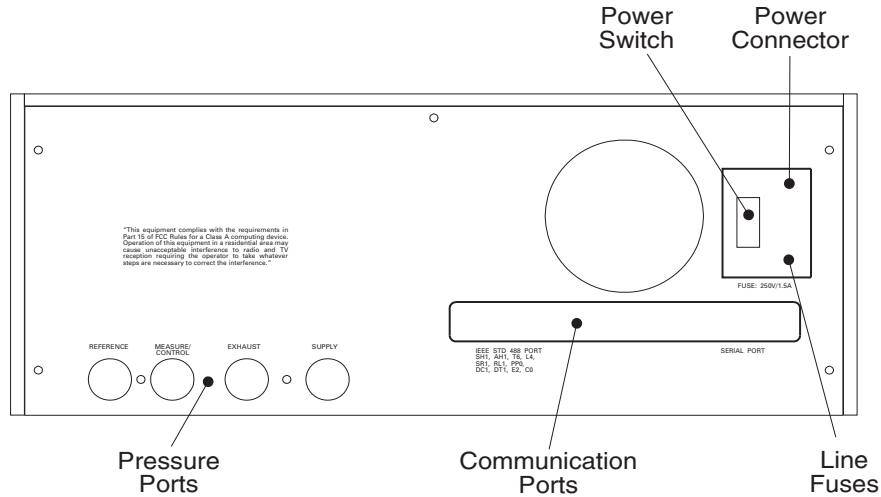

Figure 1.2 - Rear View

Electrical Module

The internal electrical module (figure 1.3, shown with its cover removed) is self contained and can be replaced as a unit. It consists of the input power module, a fan, a power supply, a computer assembly, a 3.5 inch disk drive and a flash disk.

The drive is accessible by removing the rear panel which is attached by seven screws. Note that the plug-in printed circuit cards are not necessarily in the order illustrated.

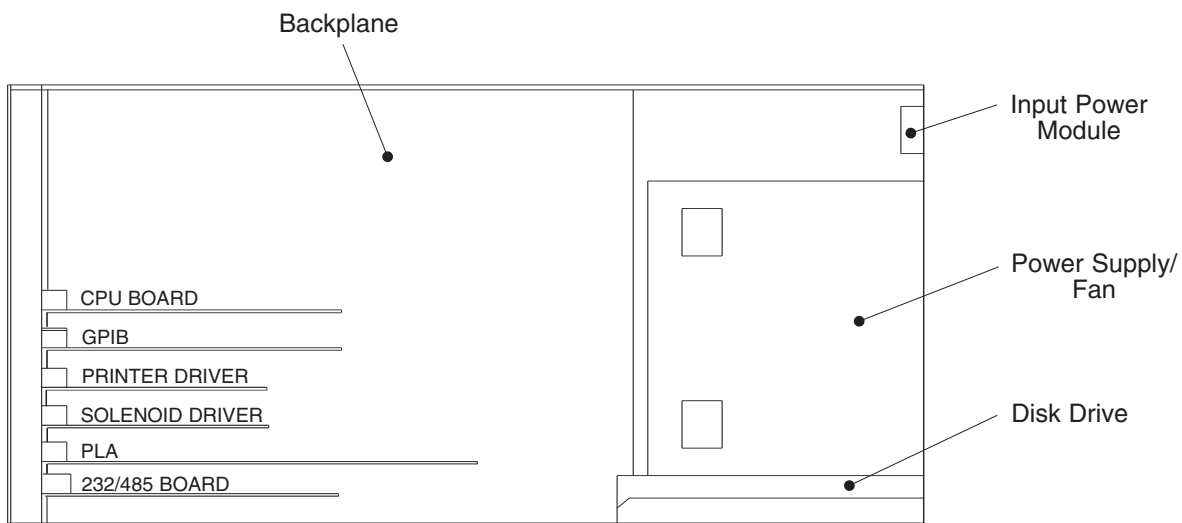

Figure 1.3 - Top View of Internal Electrical Module

Pneumatic Module

The pneumatic module (figure 1.4) includes a primary Silicon Pressure Transducer (SPT) consisting of a sensor inside a rugged aluminum housing. The pneumatic module also includes a regulator pressure controller, an auxiliary transducer, a manifold, and all of the interconnecting plumbing. The pneumatic module also has the cables required to connect it to the electrical module. In addition, this module may include as options, one or two additional transducers (3 SPTs maximum), shown at address #01 and #02.

The electrical and pneumatic modules are each self-contained and can be replaced individually. System accuracy is maintained when any component is replaced because the transducer's calibration data resides on the transducers.

The only moving parts in the PCS 400M are the fan, the disk drive mechanism, the pneumatic flow controller diaphragms and valves, and the solenoid valve plungers. There are no internal user adjustments.

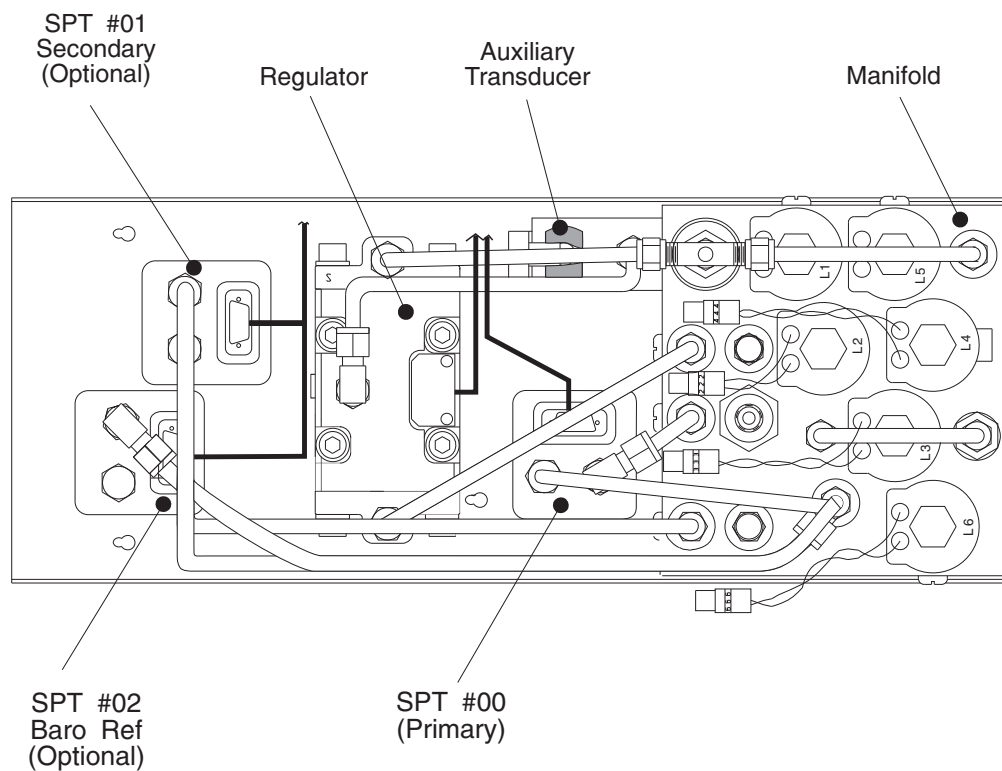

Figure 1.4 - Top View of Pneumatic Module
Shown configured with three SPTs (maximum)

Chassis Assembly

The chassis assembly acts as the housing for the system. Each of the major components is easily removed and replaced using basic hand tools. The layout of the internal system is illustrated in the figure below.

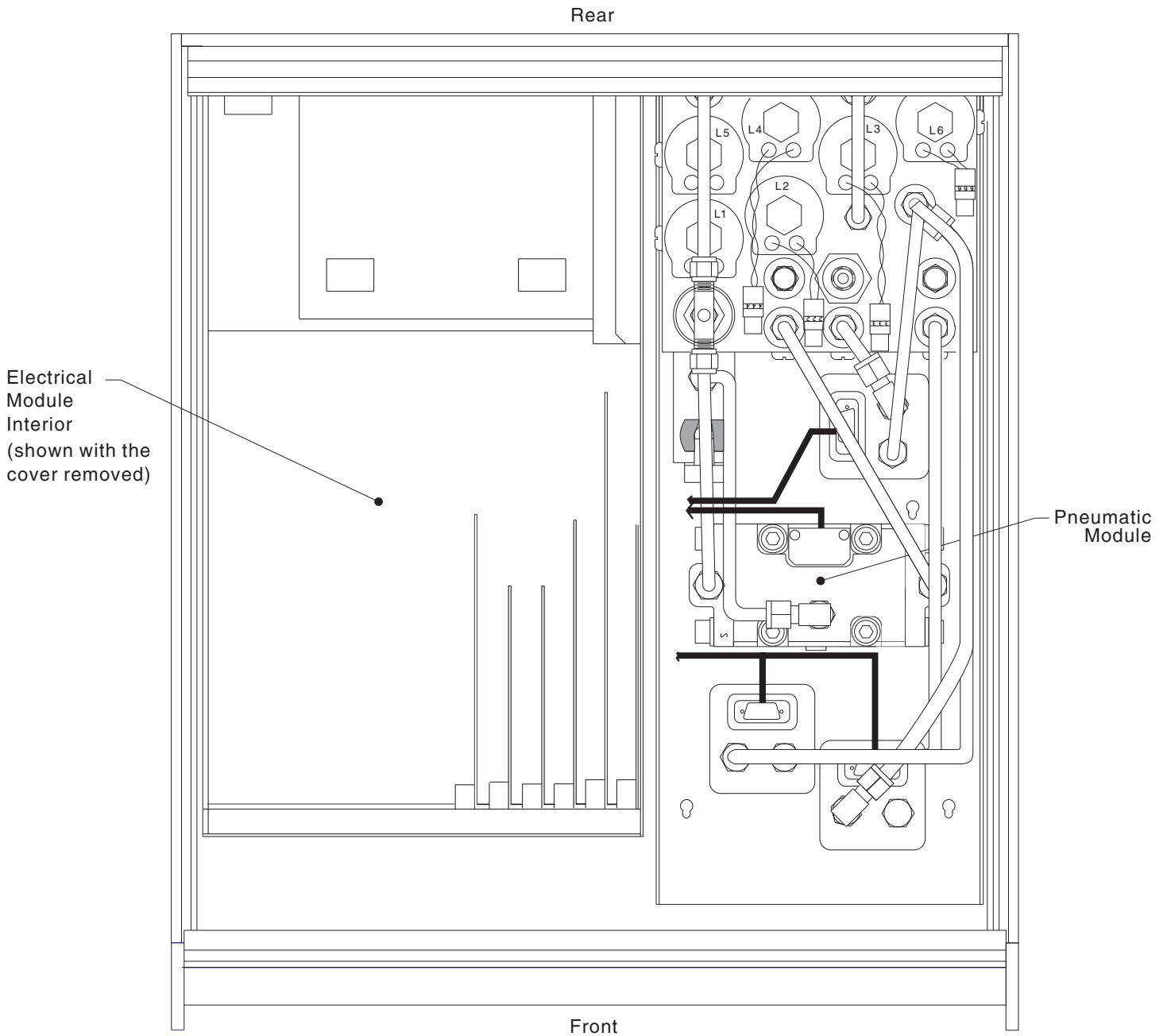

Figure 1.5 - Top View of Chassis Assembly

SUMMARY OF PCS 400M FUNCTIONS

Below is a list giving a brief description of the various functions available to the PCS 400M. This listing begins with descriptions of the three function keys on the bottom row, progresses from [1] through [9] in numerical order, then ends with [CE], [+] and [-]. The listing begins with the key cap inscription shown in brackets, followed by the mode legend for the key in capital letters, and finally a sentence or so of descriptive text.

Detailed explanations for all of the functions, and how to access them, are provided in Section 3, *Local Operation*. Additional information can also be found in Section 4, *Remote Operation*.

Key	Function	Description
[0]	EMUL	Function key EMUL is used to access emulation modes.
[.]	SEQ	Sequences: NOT SUPPORTED YET.
[=]	LOCAL	Function key LOCAL is used to return the unit to local operation mode.
[1]	CALIBRATION	Allows the user to calibrate internal and external pressure sensors and some functions of the instrument. Sensor Zero Sensor Span Baro Cal
[2]	TEST	Provides the means to quickly test various internal electrical and pneumatic functions or components. Transducer Exhaust Pressure Solenoid Valves Supply Pressure Regulator
[3]	SETUP	Allows the operator to select certain items or functions and set parameters. Active Transducer Cont Stable Window & Delay Restore Defaults Control Limits Pressure Rate/Peak Chg Passwords Filter
[4]	METRIC	Allows the user to convert pressure reading to the metric units selected from a list. The selected units will be displayed with any mode that displays pressure readings.
[5]	ENGLISH	Allows the user to convert pressure readings to selected English units.
[6]	GPIB	Provides a means to set up address for use with GPIB communications.
[7]	STANDBY	Places instrument in the "Standby Mode". The last measured or controlled pressure will be displayed.
[8]	MEASURE	Measures the pressure at the "Measure/Control" pressure port.
[9]	CONTROL	Generates a pressure in response to a command point set via the keypad or a remote command.
[CE]	VENT	Vents the "Measure/Control" pressure port to atmosphere.
[+]	ID	Displays instrument name, software version, chassis serial number and full scale range.

[-]	SERIAL	Provides a way to set the parameters to be used with RS-232 communications.
		Address Baud Rate Data Format
[2nd]	2nd	Toggles keypad between numeric and mode functions.

POWER UP!

You can confirm that your PCS 400M is operational right now. Simply apply power to the power connector on the rear of the instrument, remove any plastic plugs from the PRESSURE and REFERENCE ports and turn the power switch ON. When the PCS 400M is turned on it goes through an initialization process which includes scanning the internal configuration for file code errors.

About one minute after power is applied the full display will come on. With no pressure connected, an absolute instrument of sufficient range will display atmospheric pressure, while a gauge instrument will display at or very near zero pressure. In any case the pressure will be displayed in the measurement units that were specified when the instrument was ordered.

This confirms that the unit is ready to use. If this is your first time to use a PCS 400M please review the Warnings and Cautions information inside the front cover. Then take the time to familiarize yourself with the *Installation* and *Operation* sections of this manual and the 'Menu Tree' provided there. The tree illustrates the command structure and the functions available from the front panel keypad.

MENSOR SERVICE PLUS

If you have problems using your PCS 400M and you don't find the answer in this manual, contact Mensor at 1.800.984.4200 (USA only), or 1.512.396.4200 for personal assistance, or at any of the on-line addresses listed in the front of the manual. We are ready to help.

Mensor's concern with the welfare of this instrument is not limited to the warranty period. We provide complete repair services beyond the warranty, as explained in Section 5, *Maintenance*.

CALIBRATION SERVICES

In addition to servicing our own products Mensor can perform a complete pressure calibration service, up to 20,000 psi, for all of your pressure instruments. This service includes a Calibration Certificate and a record of traceability to the pressure standards of the National Institute of Standards and Technology (NIST).

ACCREDITATIONS

Mensor Corp. is registered to ISO 9001:2000. The calibration program at Mensor is accredited by A2LA, as complying with both the ISO/IEC 17025:2005 and the ANSI/NCSL Z540-1-1994 standards.

INSTALLATION

MOUNTING

The instrument can be set up on a table-top or it can be rack-mounted. For rack-mount installation, see the instructions in Section 8, *Options*.

The special sensors used in the PCS 400M are relatively insensitive to tilt and vibration. However to further assure stability and accuracy, excessive motor or machinery vibration of the mounting surface should be avoided.

PRESSURE CONNECTIONS

NOTE: When making up connections to the o-ring adapter, use a back-up wrench to prevent over-stressing the threads in the manifold block.

The pressure ports on the rear manifold block are female 7/16 - 20 SAE/MS straight threads per MS16142 and SAE J514 table 14. They require a tube fitting boss seal with an o-ring per MS33656. Mensor provides female 1/8 NPT adapter fittings with the instrument. The pressure connection can be made to these adapters with the proper mating hardware. We recommend the use of either Loctite Hydraulic Sealant or teflon tape on the threads of the male pipe fitting. Do not use sealants on fittings sealed with an o-ring. The integrity of the seal is particularly important since even microscopic leaks can cause errors in measurements.

Figure 9.2 is a pneumatic schematic of the internal plumbing (see figures 9.3 through 9.6 in the *Appendix* for additional pneumatic schematics showing optional configurations).

Table 9.5 in the *Appendix* shows the status of solenoid valves L1 through L6 during different operating conditions. Requirements for connecting to the various ports on the PCS 400M manifold are given below.

SUPPLY Pressure Port

Connect a pressure source to the SUPPLY port of the PCS 400M. This pressure will be used to derive the CONTROL pressure output at the MEASURE/CONTROL port. The supply pressure must be greater than the highest control pressure that will be commanded which is usually the full scale (FS) range of the instrument. For more information on supply pressure requirements see 'Supply Pressure' in the *Specifications* section.

EXHAUST Pressure Port

The EXHAUST pressure port is either left open to atmosphere or connected to a vacuum pump in order to control at pressures below atmospheric pressure. A vacuum pump will also improve control for positive pressures below 0.25 psig.



CAUTION: HIGH NOISE LEVELS.

As pressure decreases compressed gas will escape out the EXHAUST port. For ranges above 600 psi high noise levels may result during such pressure releases. To overcome objectionable exhaust noise either install a muffler or route the port to a remote location.

MEASURE/CONTROL Pressure Port

The MEASURE/CONTROL port is a bi-directional port. It can receive an unknown pressure to be measured, or upon command it can output a controlled pressure to external devices. In the MEASURE mode, solenoid valve L5 is closed (see table 9.5, Solenoid Valve Truth Table, in the *Appendix*). This isolates the regulator from the port but leaves the measure path open to the transducer(s). In CONTROL mode, L5 is opened to allow the regulated pressure output to reach the same port.

For optimum CONTROL performance the external system connected to this port should consist of a total volume between 0.01 and 0.5 liters. External volumes less than 0.01 liter will decrease control stability, and volumes greater than 0.5 liter will increase overshoot and control times.

REFERENCE Pressure Port

If an optional Barometric Reference Transducer (BRT) is included in the PCS 400M, the REFERENCE port might be internally connected to its pressure port. If there is no BRT then the REFERENCE port is either connected to the reference port(s) of the gauge pressure transducer(s), or internally plugged on absolute units. Refer to the *Appendix* section of the manual for the appropriate pneumatic schematic diagram that applies to your instrument.



CAUTION: VACUUM PUMP USE.
 Do not connect a vacuum pump to the reference port of gauge pressure units of 5 psig or less. Gauge pressure sensors in these low ranges can be destroyed by subjecting them to negative pressure. Optional dual differential relief valves are available to prevent such damage.

POWER ON

After the pressure connections are secure, apply power to the power connector on the rear of the instrument. Turn the power switch to ON. The instrument will go through a brief initialization process and system check. The display will light up a portion of the leading character on the top line to indicate it has started. After about 60 seconds the screen will change to display the instrument name, the software version number, the chassis serial number, and the fact that it is initializing. In the following examples n represents a number from 0 to 9.

```
MENSOR PCS-400M Vn.nn      SN nnnnnn
INITIALIZATION....
```

The second line is quickly replaced by MAX RANGE nnn.nnn PSI A (or PSI G) to indicate the full scale (FS) range of the primary transducer.

At the end of the initialization process the screen will default to the STANDBY mode, indicating that the PCS 400M is ready to use. A warm-up period of at least 45 minutes is advised for greatest accuracy.

```
STANDBY MODE:
MEASURED:      nn.nnn PSI A
```

SYSTEM CHECKOUT

With the system properly plumbed and powered on, and the supply pressure at the correct value, press [2nd] [CE] to enable the VENT mode, and observe the displayed pressure. This will be close to zero on a gauge instrument, or barometric pressure on an absolute unit. To begin the checkout enter the following keystrokes on the keypad:

Control Pressure Check

[2nd] [9] to enter CONTROL mode which places a question mark prompt (?) on the display. Next, enter a number value..

[n...n] where n is a number. Enter a value approximately fifty percent of the FS range of the primary transducer, and then..

[=] The regulator will begin to slew to the commanded value. The changing pressure will be displayed with a [U] to indicate that the pressure has not stabilized. When the pressure settles at the command point the [U] will be replaced by [S] to indicate the pressure is stable. If no problems are observed, press..

[n...n] Enter a number value equal to the FS range of the unit, then..

[=] Wait for the pressure stable indicator [S], then proceed to the leak check.

LOCAL OPERATION

A graphic menu tree has been placed at the end of this section, and a larger, fold-out menu tree has been placed inside the rear cover pocket of this manual for your convenience. It might help to keep a copy of the menu tree handy while following the text of this section, and also to post one near the instrument until operators are familiar with the front panel functions.

DISPLAY

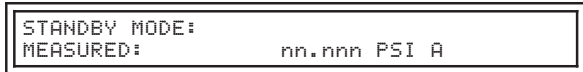

Upon completion of the initialization process the display will stabilize as above, where “n” represents the number value of the pressure trapped in the primary transducer. The system was configured at the factory to display pressure in the units that were specified when the instrument was ordered. Other measurement units can be selected by the user, as explained in the text under Mode Functions, and as shown by the menu tree.

The display consists of two lines of 40 characters each.

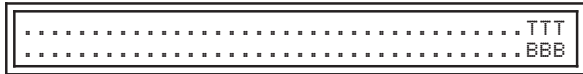

The last three characters of the top line (TTT) are reserved to display either 2nd or [R] while the last three characters of the bottom line (BBB) are reserved to display [S] or [U] while in CONTROL mode. The meaning of each display is:

Top Line:

- 2nd the keypad is in MODES condition; else is NUMERIC input.
- [R] the PCS 400M is set for REMOTE operation and keypad is disabled; else is LOCAL operation.

Bottom Line:

- [S] the displayed control pressure is STABLE.
- [U] the displayed control pressure is UNSTABLE.

These definitions are explained in more detail under the heading KEYPAD, which is next.

KEYPAD

The four-by-four matrix of membrane input keys on the front panel is composed of sixteen multi-purpose switches. Each switch has a tactile feel for closure, and an audible “BEEP” to confirm entry. A low frequency “BLAP” is emitted for an unacceptable entry or value. The effect of any individual key press depends on the present situation as shown on the display, and on the condition of the [2nd] key which toggles the keypad between NUMERIC entry and MODE selection. The next few pages will explain each key entry.

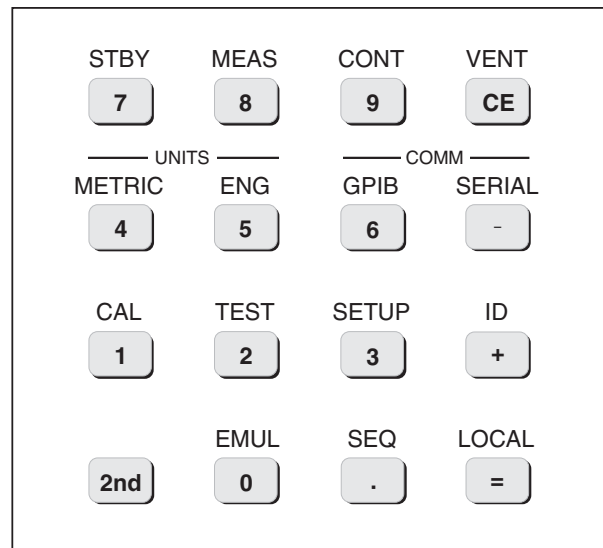

Figure 3.1 - Keypad

Numeric Entry

If 2nd is not showing on the display, then each of the fifteen numeric keys enter the number value or the math operation (=, +, -, or CE) shown on the center of the pad. Numbers being entered are not recognized by the system until the = key is pressed. The sixteenth key, labeled [2nd], toggles the other fifteen out of the NUMERIC entry state, and into their MODE state.

Mode Entry

If 2nd is showing on the display the fifteen numeric keys are in the MODE state and will function according to the label above each key. The next press of the [2nd] key will return all keys to their NUMERIC functions.

Menu Operations

The four math operator keys have an alternate function in some menu modes. The display will sometimes include [USE +, -, =, CE]. When such a prompt is displayed these four keys will function as follows:

[CE] CLEAR ENTRY	Clears the last keypad entry and returns the display to its previous condition.
[+] SCROLL AHEAD	Scrolls one step down the menu tree to the next lower level of the branch. From the bottom of the branch the next scroll will wrap around to the top item on the same branch.
[-] SCROLL BACK	Exactly the same as SCROLL AHEAD, except in the opposite direction. Wrap will jump from the top of a branch to the bottom of that same branch.
[=] EXECUTE	Enables the displayed function, or allows access to a lower level menu under the displayed function. Also used to execute the entry when entering a number series such as commanding a new control pressure point or a new filter window value.

Mode Functions

In their mode condition, the four top keys on the keypad enable the four primary pressure operations of the PCS 400M. These are STANDBY, MEASURE, CONTROL and VENT, and are referred to as the functional modes. The rest of the mode keys access menus of secondary functions that have been grouped according to each key's label. In general, when leaving a menu mode, either by activating a certain procedure, or by pressing [CE], the system returns to the functional mode it was last in, except pneumatic tests always return to STANDBY.

A description of each primary function and menu choice is listed below. It will help to have a menu tree at hand while going over this listing. The list shows each keycap legend, the label above it, and a brief functional description for each item on the menu tree. The list shows any sub-menus, and the key strokes that will bring them to the display. For any mode first press [2nd] (2nd will appear at the end of the top line of the display), then press the desired mode key. Generally, pressing [=] will either activate the procedure on the screen if it is an end item, or else will bring up the next sub-menu. Pressing [+] will progress down one level for items of the same rank on the menu tree. Press [-] to back up one level of the same rank, or [CE] to back up to the next higher rank. From the top of a menu, [CE] defaults back to the previous functional mode.

The following list of menu items steps through keycap [0], [.), [=], then [1] through [9] and ends with [+], [-], [CE], and [2nd]. Immediately after the key listings there is additional text to expand on those menu items marked with an asterisk.

<u>KEY</u>	<u>LABEL</u>	<u>DESCRIPTION</u>
[0]	EMUL	Used only for some options.
[.]	SEQ	Sequences: not available yet
[=]	LOCAL	Returns the unit to local operation mode.
[1]	CAL	Allows the user to calibrate transducers from the front panel. After entering the CAL mode the [+] and [-] keys will scroll as usual, but to enable any of these functions will require entry of a recognized password.
[=]	Adjust Transducer Zero:	Provision for resetting the zero offset of selected transducer.
[+]	Adjust Transducer Span:	Provision for resetting span sensitivity of selected transducer.
Optional Function:		
[+]	Calibrate with Barometric Reference:	Uses the optional Barometric Reference Transducer (BRT) as a standard to calibrate the active transducer.
[=]	Password:	6 digit user definable authorization code, initially set to 123456. See 'Chg Password' under SETUP Functions.
[2]	TEST	Performs a built-in test on certain electrical and pneumatic functions from a menu of choices.
[=]	Transducer:	Tests the active sensor for valid RAM checksum; displays pressure and temperature A/D counts until [CE] or [2nd] [any].
[+]	Supply Pressure:	Estimates the pressure at the SUPPLY port up to 110% FS max.
[+]	Exhaust Pressure:	Tests for presence of a vacuum on the exhaust pressure port; estimates the vacuum that can be achieved in approximately 20 seconds.
[+]	Regulator:	Pass/Fail test of each reed valve in the regulator for minimum pressure change. Note: Run this test only with 0 psig on the REFERENCE pressure port. Supply and/or exhaust pressure is required.
[+]	* Manual Solenoid Valves:	User can actuate manifold solenoid valves separately or in any combination. (CAUTION: See text under 'Manual Valves Test'.)

- [3] SETUP Allows the operator to define limits and setup options on certain items selected from the following menu:
- [=] *Active Transducer: Displays SN, Address and FS of any transducer in the system, and selects which is active or AUTORANGE if multi-range system; default is the primary transducer at address 00. (See text under "Transducer".)
 - [+] Control Limits Setup: Select control mode and set limits.
 - [=] Control Mode, select normal or rate
 - [=] Normal Control Mode
 - [+] Selected Rate
 - [+] Control Pressure (Rate): Set Rate for units/sec.
 - [+] Control Pressure (Normal) minimum: User sets lowest control pressure: default is 0 psi.
 - [+] Control Pressure (Normal) maximum: User sets highest control pressure: default is FS of primary sensor.
 - [+] Filter: Exponential smoothing of pressure reading.
 - [=] Window: Enter pressure value in the measurement units to be included in the filter; ex: 0.001 = +/- 0 .001 psi; default = 0.025% FS.
 - [+] Filter %: Enter 0 to 99% (Reading = last read * (%) + current read *(1-%)); default = 90%.
 - [+] Control Pressure Stable: Sets parameters for pressure stable signal [S].
 - [=] Window: Enter pressure value acceptable as stable pressure; default is ± 0.004% FS.
 - [+] Delay: Set number of consecutive valid readings required (approx. 33/sec) to indicate pressure stable; max 999 = approx 16 sec; default 67 = approx 2.0 sec.
 - [+] Pressure/Rate/Peak: Selects the format to appear on the bottom line of the display. (See additional text under 'Rate Mode'.)
 - [=] Pressure: Normal, default condition.
 - [+] Press/Minute: Display rate of change per minute of the measured pressure.
 - [+] Press/Second: Same as above except time is per second.
 - [+] Peak +: Latches and displays the highest measured pressure since last reset; press [CE] to reset.
 - [+] Peak -: Latches and displays the lowest measured pressure since last reset; press [CE] to reset.

- [+] *Restore Defaults: Returns settable parameters to their default values. (Default values are defined under the heading 'Default Values' later in this section.)
- [+] *Change Passwords: Two password levels are provided; the master password allows access to all protected functions, including changing both passwords. The master (Calibration) password was set at the factory to 123456. Both the master and the lower level (Zero) password must be set or changed after entering the master password. (See the text under 'Dual Passwords'.)
 - [=] Master: Set or change the master password.
 - [+] Zero: Change the zero password.
- [4] METRIC Converts all pressure readings to the metric units selected by the user from the menu.
- [5] ENG Converts all pressure readings to the English units selected by the user from the menu.
- [6] GPIB Provides a means to set parameters for GPIB communications. (See *Remote Operation* section for additional information.)
 - [=] Address: Set the GPIB address to user's requirements
- [7] STBY Standby traps and displays the internal pressure. (Can be used for emergency shut-down.)
- [8] MEAS *Measures the pressure at the MEASURE/CONTROL port. (See text under 'Measure Mode'.)
- [9] CONT *Outputs a controlled pressure to the MEASURE/CONTROL port equal in value to the numeric value entered on the keypad, or at a controlled rate of change for RATE mode. (See text under 'Control Mode'.)
- [+] ID Returns instrument name, software version number, instrument serial number, and the primary range.
- [-] SERIAL Sets parameters for serial communications. Refer to the RS-232 portion of the *Remote Operation* section for details.
 - [=] Baud/Rate: Select the appropriate transmission rate from a menu.
 - [+] Data Format: Select the format from a menu.
- [CE] VENT Vents the MEASURE/CONTROL pressure port to atmosphere.
- [2nd] Toggles the keypad between NUMERIC and MODE functions. MODE entry is active when 2nd is on the display; NUMERIC entry is active when 2nd is not displayed.

DEFAULT VALUES

Some variable features have default settings which are enabled immediately after RESTORE DEFAULTS is commanded from the front panel, or a DEFAULT command is issued over a remote bus. The resulting default values are listed below:

Table 3.1 - Default Values

Feature	Standard PCS 400M
Engineering Units	PSI
Active Sensor	Address 0
Autorange	ON (only for multiple internal sensors)
Emulation Mode	OFF (defaults to native gauge or abs measurements)
Display	Pressure (not Rate or Peak)
Remote Ports	IEEE port initialized
Measure Filter Percent**	97%
Measure Filter Window	0.025% FS
Control Stable Window*	0.004% FS
Control Stable Delay	67 readings
Control Mode	Normal (not Rate or External)
Pressure Step	0 (no response to [+] or [-] in Control Mode)

* (Control Stable Window Default is 0.008% for FS < 2 psi)

** (Filter Percent is 99% for FS <10 psi)

TRANSDUCER

The highest full scale range transducer in the system used for pressure control will be an internal transducer. This is designated as the primary transducer, and is assigned address 0. The pressure regulator is configured based on the pressure range of this transducer, and no other transducer can be of a higher pressure range than the primary. (Throughout this manual the terms 'sensor' and 'transducer' are used interchangeably unless specifically defined.)

Address

The addresses for internal transducers are assigned at the factory and should not be changed. The serial number, address and range of each transducer is recognized by the PCS 400M. These identity features are displayed on the front panel for the transducer under SETUP on the menu tree. To see the active transducer identity in the display use the key sequence: [2nd] [3] [=].

To view information about other transducers connected to a multi-range system press [+] [+] ... [+] which will scroll the display to the next higher address transducer, and on, through the full transducer list. When the highest address transducer of a multi-range unit is displayed the next [+] will present the AUTORANGE screen.

To exit without affecting the current active transducer status press [CE].

Active Transducer

The active transducer is identified by the display along with any pressure readings. If there is no identity showing then the pressure is from the primary transducer. Otherwise, the display will show the transducer address on the bottom line, i.e., press [2nd] [9]:

```
CONTROL PRESS: (NORM) nn.nnn PSI A
MEASURED @ 01:      nn.nnn PSI A [S]
```

This display shows that the instrument is in CONTROL mode, at a specified value (nn.nn PSIA), and that the pressure is being measured by the secondary transducer assigned address 1 (@ 01), and that the pressure is stable [S]. To select a different transducer to be the active transducer, or to select AUTORANGE, key in

[2nd] [3] [=] [+] [+]...

until the transducer to be activated appears in the display. When the correct transducer is showing press [=] to execute the command to SET ACTIVE TRANSDUCER.

MEASURE MODE

Remember, the primary transducer is the highest range internal transducer. Do not apply any pressure to the MEASURE/CONTROL port that exceeds this transducer's overrange capacity.

In MEASURE mode the system will recognize the last active transducer used in CONTROL mode. If, for example, the unit was in CONTROL using the lower pressure (secondary) transducer, that transducer will remain active when switched to MEASURE. If the pressure applied through the MEASURE/CONTROL port exceeds the limit for the secondary transducer the protective relief valve will open. The recommended practice for multiple internal transducers is to always determine the current active transducer prior to switching to MEASURE mode, and then change active transducers when necessary, or run AUTORANGE which lets the system select the most suitable transducer. (AUTORANGE is explained below).

A potential hazard is that pressures in excess of the secondary transducer limit can be trapped inside the pneumatic system if the instrument was last used in CONTROL mode. If a lower range transducer is then selected and placed in MEASURE mode, that high pressure will appear momentarily at the lower transducer's sensing element. As a matter of practice, DO NOT activate a lower

pressure (secondary) transducer until the internal pressure has dropped to a level at or below its full scale range.

These cautions do not apply to the optional barometric reference transducer. If one is present, it is internally isolated from the rest of the pneumatic system, and can be made active, and placed in MEASURE mode at any time with complete safety.

Now, with all of that said, to measure pressure press keys [2nd] [8]:

```
MEASURE MODE:
MEASURED @ 01:      nn.nnnn PSI A
```

Pressing [=] is not required. The unit immediately displays three items of information: 1, the mode (top line); 2, the active transducer (MEASURED: blank if the primary transducer is selected, or @ nn: for a selected secondary transducer); and 3, the pressure applied to that transducer's pressure port (nn.nnnn PSI A).

If the measured pressure is at or below another transducer's FS range, then that transducer should be activated in order to get the most accurate pressure readings. Generally, using the lowest available range transducer that is still above the pressure to be measured will provide the greatest resolution and best accuracy.

Autorange

The AUTORANGE feature is now standard for units with multiple internal transducers. It functions similar to the feature provided on many digital multimeters. With AUTORANGE enabled the instrument selects the internal transducer that will provide the highest resolution for the pressure being sensed. When selected it is operational in any of the four function modes: STANDBY, MEASURE, CONTROL or VENT. In AUTORANGE the system will automatically switch between transducers at the following crossover points:

Upscale: If there is a higher range transducer than the active transducer the switch will occur at 5% over FS for the active transducer.

Downscale: If there is a lower range transducer than the active transducer the switch will occur at 2.5% above FS for the lower range transducer.

With AUTORANGE off (normal range-hold operation) all pressure functions are directed to the currently active transducer. That transducer will

remain active until either another transducer is selected to be active (by local or remote command), or the AUTORANGE is enabled. Relief valves have been incorporated to prevent damage due to fast pressure transients.

To enable AUTORANGE:

Press [2nd]
 [3] SETUP
 [=]
 [+] or [-] until the display shows:

```
SELECT ACTIVE RANGE      (USE +, -, =, CE)
ANY INTERNAL TRANSDUCER (AUTORANGE)
```

then press [=] to enable AUTORANGE.

To disable AUTORANGE:

Press [2nd]
 [3] SETUP
 [=]
 [+] or [-] until desired transducer is displayed

then press [=] to range-hold using the displayed transducer.

CONTROL MODES

The CONTROL mode provides the user the means to output a specific, highly regulated pressure. Two different control modes are a standard feature of the PCS 400M. The two standard modes are identified as NORM (for NORMAL), and RATE under the SETUP menu heading.

NORMAL Mode

NORMAL control mode is the default mode and is indicated on the top line of the display by **NORM**. This mode achieves stable pressure at the new control point in the shortest time.

RATE Mode

RATE control mode is indicated by **RATE** on the top line of the display, and should be selected when overshoot must be kept to a minimum. RATE mode provides a means to control the rate of change in pressure units. This mode is useful where rapid pressure changes would be harmful to sensitive devices under test (DUTs). Overshoot in RATE mode is less than in NORMAL mode, but the time to achieve stable pressure will be longer than in NORMAL mode. The minimum and maximum controllable rates of pressure change are dependent on

the FS range of the PCS 400M as shown in the following table.

Table 3.2 – Min/Max Rate

Full Scale	Minimum	Maximum
≤5 psi	0.00025 psi/sec	0.1 psi/sec
>5 and up to 100 psi	0.0025 psi/sec	1 psi/sec
>100 and up to 1000 psi	0.025 psi/sec	10 psi/sec

The maximum pressure rates shown above are based on external volumes of 0.5 liter, or less. Larger volumes will reduce the maximum rate that can actually be achieved. When a new control point is entered the PCS 400M will attempt to control the pressure change at the last rate value specified. As the pressure approaches the control point the control rate of change will decrease to prevent overshoot at the commanded point. Because of this automatic slow-down it may not be possible to achieve the set rate between small pressure steps. Note that when the [S] for pressure stable appears in the display it indicates stability at the control point rather than indicating a stable pressure rate.

Multiple Transducers

For instruments with multiple transducers, in CONTROL mode with AUTORANGE on the PCS 400M automatically activates the lowest range transducer that can effectively measure the commanded pressure. For example, an instrument that has transducers of 150 psi and 30 psi would automatically switch to the 30 psi transducer when commanded to control at 10 psi. The address of the active transducer (@ 01) is included on the second line of the display as shown in the screen, below. The [S] signifies that the controlled pressure is stable at the measured value displayed.

```
CONTROL PRESS:(NORM)10.0000 PSI A
MEASURED @ 01:      10.0000 PSI A [S]
```

Likewise, if the control point is set to 31 psi while in AUTORANGE the system will default to the 150 psi primary transducer and display as follows.

```
CONTROL PRESS:(NORM)31.000 PSI A
MEASURED:           31.000 PSI A [S]
```

Notice in particular the two differences; 1, the transducer ID following MEASURED has disappeared; and 2, there is one less digit of resolution. Since the 150 psi transducer is active, the seven character resolution provides only three places

following the decimal point. The seventh character is the leading zero, which is blanked.

Setup for Control Mode

To have the PCS 400M provide an output pressure to the MEASURE/CONTROL port, connect an input pressure to the SUPPLY port. Refer to the *Specifications* section for optimum supply pressure requirements. With fittings secured and source pressure applied, press keys [2nd] [9] to get the following display:

```
CONTROL PRESS:(NORM)    ? PSI A
MEASURED:                nnn.nnn PSI A
```

Input a Control Point Value

The ? prompt on the top line is asking for a new control pressure value. The bottom line indicates the primary (no ID after MEASURED:) transducer is now active, and displays the current measured pressure. Pressing [=] will return the system to the previous control set point.

A maximum of seven characters, including the decimal point, can be entered in response to the ? prompt. It is not necessary to enter leading zeros, nor trailing zeros after the decimal point. Thus, if 10.0000 psi is the desired output merely input [1] [0] [=]. When entering a numerical series pressing [CE] will clear the last digit entered, and another [CE] will delete the now last digit, and so on. Entering, clearing and re-entering can go on until [=] is pressed. When [=] is engaged the system immediately will begin to slew the output pressure (MEASURE/CONTROL port) to the newly commanded value.

Incrementing the Control Point

The control point may be jogged up or down by entering in a pressure value within the limits of the system and pressing [+] or [-] respectively. When the [+] or [-] keys are entered, the number entered is immediately added or subtracted from the control pressure point. If the instrument is in CONTROL mode, the PCS 400M will then drive to the newly commanded pressure.

This function is disabled on instruments capable of controlling negative gauge pressures.

Just like all pressure measurements with the PCS 400M, the entered step value is in currently active measurement units. Thus, setting a step value, then changing the pressure units would cause the next control mode step sequence to add or subtract the

conversion equivalent of the step value, and not the absolute number entered.

Regulator Response

While the output pressure is changing toward the new pressure the bottom display line will display [U] to indicate that the output is unstable. The time it takes to become stable, indicated by [S], is dependent on several factors:

1. The differential between the beginning pressure and the commanded pressure;
2. The settings for the measure FILTER WINDOW and % AVERAGE;
3. The settings for the CONTROL PRESSURE STABLE WINDOW and DELAY;
4. The external volume size. Optimum external volume is from 0.01 to 0.5 liter.
5. And, finally, the closer the control point is to zero pressure the more time it will take to achieve it. Absolute units take longer than gauge pressure units.

If the entered CONTROL value is higher than the range of the primary transducer pressing [=] will cause the system to emit an error sound (blap) and re-display the ? prompt.

MANUAL VALVES TEST

Each solenoid valve can be tested individually or in any combination with this procedure.



PROCEED WITH CAUTION!

This is both a powerful tool for troubleshooting the pneumatic system, and a dangerous capability to mis-direct high pressures within the internal and external system.

To use this capability press [=] and the warning screen appears. Press [=] again to enable the test and another opportunity is presented to cancel the test. Once more press [=] and a screen map of the solenoid valves appears as a row of five zeros representing L1 through L5, and a zero or an X in the sixth position to indicate the presence or absence of the L6 valve. In the display 0 signals that a valve is OFF, and a 1 shows that it is ON. Use the number keys 1 through 6 to toggle the equivalent solenoid ON (1) and OFF (0).

DUAL PASSWORDS

There are two levels of passwords in the system. One is a line level or zero password which allows access to Zero Adjustments, and the other level is a master password that will access all protected functions, including changes to passwords. In order to change either password the current master password must be entered. Since passwords are seldom used they are easily forgotten. Please keep a written record of newly entered passwords.

The master password will work for any protected function until it is changed through the SETUP/CHANGE PASSWORD function. Either password can be from one to six digits long. To allow line technicians to easily make zero adjustments the zero password could be changed to the single character "0", for example. To change either password scroll down the menus to the appropriate password to be changed. Then, at the ENTER PASSWORD prompt simply enter the current master password. Then at the CHOOSE A NEW PASSWORD prompt enter the digit or digits desired, then press [=].

The requirement for a zero password can be turned off so that zero adjustments can be made more easily. To disable the zero password requirement merely exit the CHANGE PASSWORD function by pressing [=] without entering a zero password.

Both the zero and master passwords were set at the factory to 123456. Again, since passwords are seldom used, they are easily forgotten. Please keep a written record of the latest changes as they are entered. Contact Mensor Corporation if the master password is lost.

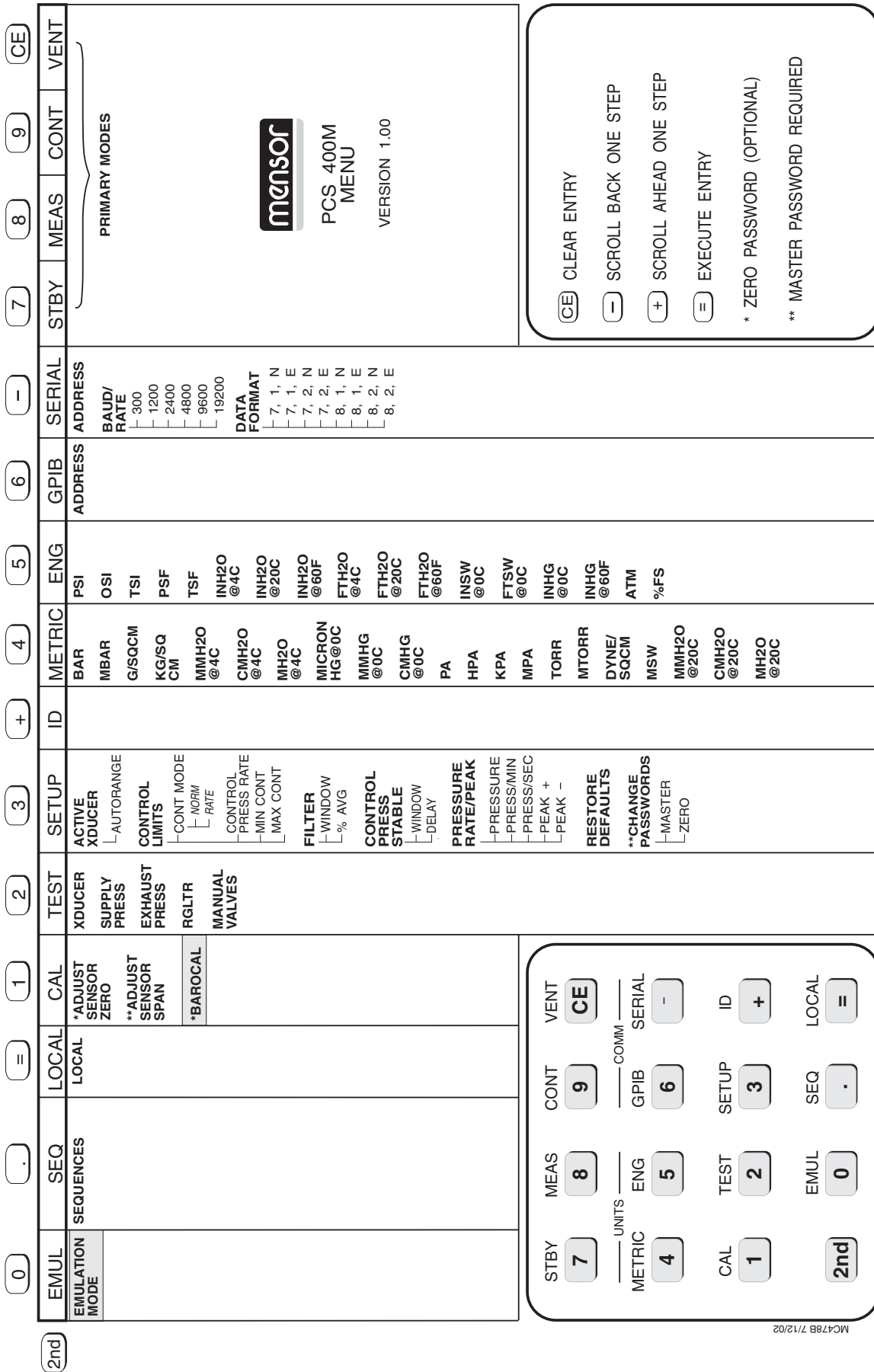

Figure 3.2 - PCS 400M Menu Tree

User's Notes:

A large rectangular area filled with a grid of small, evenly spaced dotted lines, intended for the user to write notes. The grid covers most of the page's width and height.

REMOTE OPERATION

This section provides information on two methods of remote communication with the PCS 400M; parallel operation over the IEEE-488-STD bus, and serial operation over the RS-232 bus. The operator must choose which method of remote operation to use since simultaneous use of both methods is not practical. All of the commands in the following text are the bare commands seen by the PCS 400M stripped of all programming idioms. Depending on the specific program language used, these commands may have to be preceded by or enclosed in various symbols for transmission. The PCS 400M commands are not case-sensitive, i.e., upper and lower case commands are interpreted the same. A brief IEEE sample program has been included in the *Appendix* for your convenience.

Device Dependent Messages

Device dependent messages are commands specific to the PCS 400M that are sent via a remote port (parallel or serial). These messages are device dependent because they may not be valid for any other equipment.

To send a device dependent message to the PCS 400M, transmit the message with a prefix of "_PCS4" and end the message with the selected termination character. An EOI (see EOI under 'Command Set' for a definition) can be sent with the termination character, but is not required.

IEEE-488-STD (GPIB)

The PCS 400M can be operated from a remote computer which communicates over the IEEE-488-STD General Purpose Interface Bus, commonly referred to as the GPIB. To function in this mode the host computer must contain a GPIB card and must be connected to the PCS 400M with an appropriate parallel cable.

Software to install and operate the GPIB along with programming examples is provided by the manufacturer of the GPIB card.

The IEEE-488-STD specification is available from the Institute of Electrical & Electronics Engineers Inc., 345 East 47th Street, New York, New York, 10017.

IEEE Capability Codes

SH1	full source handshake capability
AH1	full acceptor handshake capability
T6	talker with serial poll and unaddress if MLA
L4	listener with unaddress if MTA
SR1	full service request capability
RL1	full remote/local capability including LLO
PPO	no parallel poll capability
DC1	full device clear capability
DT1	full device trigger capability
E2	tri-state outputs

Device Address

The primary address of the PCS 400M on the GPIB is set using the front panel keypad. Select [2nd], [GPIB]. At the MODIFY INSTRUMENT ADDRESS prompt, enter a number from 0 through 30 as an address. Press [=] to install the new address. This number will be stored in memory and used until it is changed.

Service Request

The service request line on the GPIB (SRQ) will be asserted when an error is encountered.

Local Lockout

When the PCS 400M is in the REMOTE mode, local lockout (LLO) is in effect. The instrument will not respond to the keypad until returned to the LOCAL mode by the host computer.

Status Display

The PCS 400M indicates the status of the GPIB in the upper right of the display: [R] for REMOTE mode.

GPIB Interface Messages

GPIB interface messages are standardized commands that are a function of the GPIB interface itself.

The method of sending an interface message to the PCS 400M is dependent upon the specific computer and interface hardware and software being used. The differences occur primarily in the syntax used to invoke the desired command, particularly among different programming languages. Any GPIB controller (i.e., a computer with a GPIB card) should have available the messages defined in this section. They may be identified differently in the actual programming implementation.

DCL

The DEVICE CLEAR (DCL) command is used to reset the internal GPIB functions of all devices on the GPIB that respond to this command. The PCS 400M re-initializes itself the same as when it is going through the power-up sequence.

GET

The GROUP EXECUTE TRIGGER (GET) is used to synchronize the acquisition of data between several instruments connected to the GPIB. When the PCS 400M receives a GET the current GPIB output reading is latched until it is read over the bus. The display output will continue to update.

GTL

The GO TO LOCAL (GTL) command places the PCS 400M into the LOCAL mode. This will allow the user to change the engineering units, resolution, etc. from the front panel. The PCS 400M does not respond to the keypad while in the REMOTE mode.

IFC

The INTERFACE CLEAR (IFC) command halts all current operations on the bus.

LLO

The PCS 400M always has LOCAL LOCKOUT (LLO) enabled when the instrument is in the REMOTE mode.

SDC

SELECTED DEVICE CLEAR (SDC) is similar in function to DEVICE CLEAR (DCL) except that only the device addressed to listen is reset.

SRQ

A SERVICE REQUEST (SRQ) is sent by the PCS 400M when it detects an error.

Serial Poll

A SERIAL POLL is a high level function of the GPIB interface used to read the status byte of one particular device. Some GPIB interface manufacturers provide this as an automatic function, reading the most recent status byte from the instrument after each read or write instruction. Others require the user to specifically program the GPIB to do a SERIAL POLL of a device.

A common use of the SERIAL POLL is in a program module designed to respond to the service request (SRQ) line on the GPIB. Many GPIB interface manu-

facturers provide a way to check the status of the SRQ line. If it is asserted, some instrument on the bus requires service. The service may involve simply acknowledging a change in instrument status, completion of some internal function of the instrument, or indicate the existence of an error. The status byte returned by the serial poll will determine the required service and clear the SRQ. The PCS 400M will always return a status byte of 00H unless an error condition exists. If some other error code is returned refer to table 4.2 for a listing of all of the error codes and messages.

PCS 400M Command Set

Definitions

1. **< >** Optional information in the command.
2. **•** Delimiter required between adjacent elements in a command. A space, comma or tab are valid delimiters.
3. **unitno** One or two digit number that designates the units of measure. See the 'Measurement Units' table in the *Appendix*.
4. **value** A floating point number that can take the following format:
decimal_digit<decimal point>
<decimal_fraction><exponent_part signed_integer_exponent>
Examples: 23, 23.45, 23., .2345e2, .23E+2, .023E-1
5. **digit** A single decimal digit.
Example: 0, 1, 2 (single digit)
6. **digits** One or more decimal digits.
Example: 1, 01, 10, 66, 12345
7. **sp** Space. (32 decimal), (20 hex)
8. **cr** Carriage return. (13 decimal), (0D hex)
9. **lf** Linefeed. (10 decimal), (0A hex)
10. **EOI** End Or Identify (End of transmission). When the ATN line is true, the EOI line is used by the controller to execute a parallel poll. When the ATN line is false, the EOI line is used by an active talker to indicate the last byte of a data message. This is optional for PCS 400M messages.

A short sample program in Microsoft QuickBasic, and a quick reference list of common remote commands are included in the *Appendix*.

Commands

NOTE: All pressure values will be in the currently active pressure units unless otherwise stated.

`_PCS4•AUTORANGE•0<lf>`

Turns AUTORANGE off. To return to RANGE HOLD a specific transducer must be assigned with the following command:
`_PCS4•XDUCER•digits`.

`_PCS4•AUTORANGE•1<lf>`

Sets the PCS 400M with multiple internal transducers to autoselect the transducer with the highest resolution for the pressure being measured.

`_PCS4•CAL•ATM`

Internal calibration of current transducer to the optional Barometric Reference Transducer (if installed). Operation vents system to atmospheric pressure and corrects the zero offset of the current transducer.

`_PCS4•CAL_DISABLE•OFF`

This command cancels the `_PCS4•CAL_DISABLE•ON<term>` command.

`_PCS4•CAL_DISABLE•ON`

This command prevents any of the following three commands from executing their respective functions:

`_PCS4•CAL•ZERO•n.n`
`_PCS4•CAL•SPAN•n.n`
`_PCS4•CAL•ATM•n.n`

If any of these commands are sent, the error flag is set (SRQ is asserted). In this case, the error response is E63-CAL FUNCTIONS DISABLED.

`_PCS4•CAL•SPAN•value`

Calibrates the current transducer span by correcting for the difference between the measured input pressure and the value specified. (Multiplication factor is limited to 0.9 to 1.1. Span corrections are allowed only in the upper half of the pressure range of the active transducer.)

`_PCS4•CAL•ZERO•value`

Calibrates the current transducer zero offset by correcting for the difference between the measured input pressure and the current units value specified. (Maximum offset is ± 16 psi, or equivalent pressure in the active units.)

`_PCS4•CTRL•value`

Sets the current control pressure to value specified. Will take effect immediately if in pressure CONTROL mode or else stored for future use.

`_PCS4•CTRLMAX•value`

Sets the maximum control pressure that can be commanded.

`_PCS4•CTRLMIN•value`

Sets the minimum control pressure that can be commanded.

`_PCS4•DEFAULT`

Sets the unit to the factory default settings (see table 3.1 in *Local Operation*).

`_PCS4•FILTERSETTING•digits`

Sets the percentage of exponential filtering that is applied when the reading is within the FILTERWINDOW using the following equation:

Reading = NR (1 - (digits/100)) + LR (digits/100)
Where: NR = new reading, LR = last reading,
digits = 00 to 99

`_PCS4•FILTERWINDOW•value`

Sets the maximum value between consecutive readings that will be filtered. Consecutive readings that differ by more than this value will be immediately displayed without filtering. Value = 0 to full scale pressure.

`_PCS4•FUNC•CTRL<•value•<unitno>>`

Set to CONTROL mode at current value unless value specified, at current units unless unitno specified. Value must be within minimum and maximum limits.

`_PCS4•FUNC•EMUL`

Accesses emulation mode.

`_PCS4•FUNC•MEAS<•unitno>`

Set to MEASURE mode in current units unless unitno specified.

`_PCS4•FUNC•STBY<•unitno>`

Set to STANDBY mode in current units unless unitno specified.

`_PCS4•FUNC•VENT<•unitno>`

Set to VENT mode in current units unless unitno specified.

`_PCS4•OUTFORM•digit`

Sets the output format (see table 4.1, Command Responses).

`_PCS4•PEAKRESET`

Resets and restarts peak pressure readings.

_PCS4•PEAKUNIT•digit

Enables the display of peak pressures. Digit must be equal to 0 for normal pressure display, 1 for maximum positive pressure display, or 2 for minimum pressure display. Resets previous peak measurements.

_PCS4•RATE•value

Sets the rate of pressure change to value (current units/sec). Value must be within the range of values shown in table 3.2 to enable rate control. If value is 0 the Normal mode is selected.

_PCS4•RATEUNIT•digit

Enables pressure rate of change units to units/min or units/sec. Digit must be equal to 0 for normal pressure display, 1 for rates displayed in units/min, or 2 for rates displayed in units/sec.

_PCS4•STABLEDELAY•digits

Sets the number of consecutive readings (at approximately 30 milliseconds per reading) that the pressure must remain within the stable window for a pressure stable indication to be generated. Acceptable range: 1 to 999.

_PCS4•STABLEWINDOW•value

Sets the pressure window that is used to indicate pressure is stable.

_PCS4•UNIT•unitno

Change units of measure to specified unitno (see table 9.1).

_PCS4•XDUCER•digits

Sets the active transducer in a multi-transducer instrument. All pressure output strings will include the measured output of this transducer.

Tests

If the PCS 400M is read over a remote port while an internal test is being performed, the instrument will respond with a "B" in the first character of the response string to indicate the instrument is busy. When the test is completed, any information reported back from the test will contain a "T" as the first character of the response string.

_PCS4•TEST•EXHAUSTP?

Determines the approximate exhaust pressure at the Exhaust port. (Used to determine the approximate minimum control pressure.)

Response: 'T value cr lf '

Where value equals the approximate exhaust pressure and units identifies the units of measure.

_PCS4•TEST•REG?

Performs a functional test of the regulator valves. Response: 'T stat value, stat value, stat value, stat value cr lf '

Where a stat = PASS or FAIL and value is the pressure change for that valve.

_PCS4•TEST•SOURCEP?

Determines the source pressure applied on the Supply port of the instrument. (Used to determine the approximate maximum control pressure.)

Response: 'T value cr lf '

Where value equals the approximate source pressure up to a maximum of 110% of the primary transducer range and units identifies the units of measure.

_PCS4•TEST•XDUCER?<•digits>

Functionally verifies main internal transducer unless other transducer is specified by digits. Tests for nominal values, not for accuracy.

Response: 'T stat, digits, digits cr lf '

Where stat is PASS or FAIL (the result of the RAM test and digits are the pressure counts and digits are the temperature counts. If no transducer is specified, the main transducer (0) is tested. If a non-existent transducer is specified, the test will be performed, but will fail with unusable counts returned.

Queries

_PCS4•AUTORANGE?

Returns 0 cr lf if in Range hold, or 1 cr lf if in Autorange.

_PCS4•CTRL?

Returns the current control point in the current engineering units.

Response: 'sp value cr lf '

_PCS4•CTRLMAX?

Returns the current maximum control pressure that can be commanded.

Response: 'sp value cr lf '

_PCS4•CTRLMIN?

Returns the current minimum control pressure that can be commanded.

Response: 'sp value cr lf '

_PCS4•EMUL?

Returns the current mode of operation.

Response: '0 cr lf if in native mode, or '1 cr lf if in emulation mode.

_PCS4•ERR?

Returns the error number and error description (see 'Error Codes'). Clears error indication and GPIB service request.

Response: 'Ennnn error_string cr lf '

Where 'nnnn' is the error number, and error_string is the description terminated with a carriage return and linefeed.

_PCS4•EXHAUSTP?

Returns the value of the last exhaust pressure test or zero if test has not been performed.
Response: 'T sp value cr lf'

_PCS4•FILTERSETTING?

Returns the current percentage of filter.
Response: 'sp digits cr lf'

_PCS4•FILTERWINDOW?

Returns the value of the filter window.
Default is 0.025% FS.
Response: 'sp value cr lf'

_PCS4•ID?

Returns instrument ID consisting of: MENSOR,PCS-400,(six digit serial number nnnnnn), (4 character version number n.nn)

_PCS4•LIST?

Returns a list of the sensors installed in instrument.
Response: 'sp 0,1,2 cr lf' for a PCS400M with 3 internal sensors, or 'sp 0,2 cr lf' for a primary and a barometric reference.

_PCS4•OUTFORM?

Returns the number of the current output format (see table 4.1, Command Responses).
Response: 'sp digits cr lf'

_PCS4•PEAKUNIT?

Returns the units of measure of the peak reading.
Response: 'sp digit, name cr lf'

_PCS4•RANGEMAX?

Returns the maximum pressure of the currently active transducer.
Response: 'sp value cr lf'

_PCS4•RANGEMIN?

Returns the minimum pressure of the currently active transducer.
Response: 'sp value cr lf'

_PCS4•RATE?

Returns the rate of pressure change setting.
Response: 'sp value, digit, mode cr lf'
value = pressure rate in units per second
digit = 0 for normal, 1 for rate
mode = NORM or RATE

_PCS4•RATEUNIT?

Returns the pressure rate of change setting (units per second or units per minute) if function is available.
Response: 'sp digit, name cr lf'

_PCS4•READING?

Returns a reading from the PCS400M in output format 1.
Response: 'sp value cr lf'

_PCS4•SOURCEP?

Returns the value of the last source pressure test, or zero if test has not been performed.
Response: 'sp value cr lf'

_PCS4•SPAN?

Returns the stored multiplication factor used to proportionally correct span offset overrange of the unit.
Response: 'sp value cr lf'

_PCS4•STABLEDELAY?

Returns the number of readings that must be within the stable window before a stable pressure is indicated. Maximum is 999, default is 67.
Response: 'sp digits cr lf'

_PCS4•STABLEWINDOW?

Returns the pressure tolerance allowed for a stable pressure indication. Default is 0.004% FS.
Response: 'sp value cr lf'

_PCS4•STAT?

Returns mode and stability flag.
Response: 'mode, stable cr lf'

_PCS4•UNIT?

Returns the number of the current units of pressure measurement, the full name with temperature, and the configuration of the sensor (absolute, gauge, differential).
Response: 'sp digits, name, type cr lf'

_PCS4•XDUCER?

Returns the number of the currently active transducer.
Response: 'sp digits cr lf'

_PCS4•XDUCERID?

Returns the internal transducer number, serial number, minimum and maximum sensor range.
Response: 'sp Mensor,6100,xducer,sn,min,max cr lf'

_PCS4•ZERO?

Returns the stored zero offset of the active transducer in the current pressure units. (Limited to values between +16 to -16 psi, or equivalent.)
Response: 'sp value cr lf'

PCS 400M Command Responses

All commands that terminate with a '?' will respond a single time in the format stated above. At all other times the standard output format will be used. The standard output normally starts with a space character (sp = 32 dec or 20 hex) to indicate a valid response. The space character will be replaced with an 'E' if an error has occurred. (The error codes and their meanings are listed in table 4.2 on the following pages.) The user must execute the '_PCS4 ERR ?' command to clear the error. This output may be changed from the default setting with the '_PCS4 OUTFORM digit' command. The following formats are valid:

Table 4.1 - Valid Output Format

Format 1: (default or OUTFORM digit = 1)	'sp value cr lf '	Where value represents the current pressure measured in the current mode and units with current transducer.
Format 2: (OUTFORM digit = 2)	'sp value, unitno, function cr lf '	Where value represents the current pressure measured in the current mode and units with current transducer, unitno is the units of measure, and function is the current mode of operation.
Format 3: (OUTFORM digit = 3)	'sp value, value cr lf '	Where the first value is the current pressure measured in the current mode and units with the current transducer and the second value is the current pressure rate of change in the current mode and the current rate units.
Format 4: (OUTFORM digit = 4)	'sp value, value, value cr lf '	Where the first value is the current pressure measured in the current mode and units with the current transducer. The second value is the minimum peak reading. And the third value is the maximum peak reading.
Format 5: (OUTFORM digit = 5)	'sp value, value cr lf '	Where the first value is the current pressure measured in the current mode and units with the current transducer. The second value is the current auxiliary (coarse) Sensor pressure in the current engineering units.
Format 6: (OUTFORM digit = 6)	'sp value, value, stable cr lf '	Where the first value is the current pressure measured in the current mode and units with the current transducer. The second value is the current control point in the current engineering units. 'Stable' will be either the string 'STABLE' or 'UNSTABLE', depending on the current pressure stable status.
Format 7: (OUTFORM digit = 7)	'sp value, no barometer cr lf ' if no Barometric Reference Transducer (BRT) is present; or 'sp value, value cr lf ' if a BRT is present.	For either string the first value is the current pressure measured in the current mode with the current transducer. In the second string the second value is the current barometric pressure in the current engineering units. This output is valid only if a barometric reference transducer is present. Otherwise the first example string is returned.

Table 4.2 – Error Codes

Code	Serial Poll Byte	Description	Error String Returned
E00	00h	reserved	unused code
E01	41h	GPIB listen/talk error	GPIB LISTEN/TALK ERROR
E02	42h	Syntax error	UNKNOWN COMMAND
E03	43h	Expected a valid _PCS4 command	EXPECTED A VALID _PCS4 COMMAND
E04	44h	Expected a valid FUNC command	EXPECTED A VALID FUNC COMMAND
E05	45h	Expected a valid CAL command	EXPECTED A VALID CAL COMMAND
E06	46h	Expected a valid TEST command	EXPECTED A VALID TEST COMMAND
E07	47h	Expected a pressure units selection	EXPECTED A PRESSURE UNITS SELECTION OR INVALID TERMINATION STRING
E08	48h	Expected a pressure value	EXPECTED A PRESSURE VALUE
E09	49h	Expected a transducer selection	EXPECTED A XDUCER SELECTION
E10	4ah	Expected a seconds selection	EXPECTED A SECONDS SELECTION
E11	4bh	reserved	unused code
E12	4ch	reserved	unused code
E13	4dh	Invalid pressure units selection	INVALID PRESSURE UNITS SELECTION
E14	4eh	Invalid control pressure value selection	INVALID CONTROL PRESSURE VALUE SELECTION
E15	4fh	Invalid rate value selection	INVALID RATE VALUE SELECTION
E16	50h	Invalid a/d unit selection	INVALID A/D UNIT SELECTION
E17	51h	Invalid zero offset value selection	INVALID ZERO OFFSET VALUE SELECTION
E18	52h	Invalid span offset value selection	INVALID SPAN OFFSET VALUE SELECTION
E19	53h	Invalid rate units selection	INVALID RATE UNITS SELECTION
E20	54h	Sensor overrange	SENSOR OVERRANGE
E21	55h	Sensor underrange	SENSOR UNDERRANGE
E22	56h	Sensor failure detected	SENSOR FAILURE DETECTED
E23	57h	Low source pressure	LOW SOURCE PRESSURE
E24	58h	Regulator failure detected	REGULATOR FAILURE DETECTED
E25	59h	reserved	unused code
E26	5ah	Internal leak detected	INTERNAL LEAK DETECTED
E27	5bh	Program error detected	PROGRAM ERROR DETECTED
E28	5ch	Memory error detected	MEMORY/COEFFICIENT ERROR DETECTED
E29	5dh	External leak detected	EXTERNAL LEAK DETECTED
E30	5eh	High exhaust pressure	VACUUM ERROR DETECTED
E31	5fh	Transducer error detected	XDUCER ERROR DETECTED

Continued on next page...

(Table 4.2 – Error Codes continued...)

Code	Serial Poll Byte	Description	Error String Returned
E32	60h	Invalid transducer selection	INVALID TRANSDUCER SELECTION
E33	61h	Invalid filter window selection	INVALID FILTER WINDOW SELECTION
E34	62h	Invalid filter setting selection	INVALID FILTER SETTING SELECTION
E35	63h	Invalid output format selection	NOT A VALID OUTPUT FORM SELECTION
E36	64h	Invalid stable window selection	INVALID STABLE WINDOW SELECTION
E37	65h	Invalid stable delay selection	INVALID STABLE DELAY SELECTION
E38	66h	reserved	unused code
E39	67h	Expected a filter setting selection	EXPECTED A FILTER SETTING SELECTION
E40	68h	Expected an output format selection	EXPECTED AN OUTPUT FORM SELECTION
E41	69h	Expected a stable delay selection	EXPECTED A STABLE DELAY SELECTION
E42	6ah	Expected a language selection	EXPECTED A LANGUAGE SELECTION
E43	6bh	reserved	unused code
E44	6ch	reserved	unused code
E45	6dh	PCS 200 command format error	PCS200 COMMAND FORMAT ERROR
E46	6eh	Control pressure overrange	CONTROL PRESSURE OVERRANGE
E47	6fh	Control pressure underrange	CONTROL PRESSURE UNDERRANGE
E48	70h	Illegal GPIB controller function	ILLEGAL GPIB CONTROLLER FUNCTION
E49	71h	GPIB error	GPIB ERROR
E50	72h	Invalid termination	INVALID TERMINATION
E51	73h	Vent mode disabled	VENT MODE DISABLED
E52	74h	Special functions not available	SPECIAL FUNCTIONS NOT AVAILABLE
E53	75h	reserved	unused code
E54	76h	Expected a valid DPC-179 command	EXPECTED A VALID DPC-179 COMMAND
E55	77h	Expected a valid DPC-179 header command	EXPECTED A VALID DPC-179 HEADER COMMAND
E56	78h	Expected a valid DPC-179 control command	EXPECTED A VALID DPC-179 CONTROL COMMAND
E57	79h	reserved	unused code
E58	7ah	reserved	unused code
E59	7bh	reserved	unused code
E60	7ch	reserved	unused code
E61	7dh	reserved	unused code
E62	7eh	reserved	unused code
E63	7fh	cal functions disabled	CAL FUNCTIONS DISABLED

PCS 200 Emulation

The PCS 200 was the predecessor to the PCS 400M. It was the first Mensor product sold with both GPIB and RS-232 capabilities. There are hundreds of these instruments in operation and it is expected that the PCS 400M will be used as a replacement for the older model in some instances. Therefore, the PCS 400M has a built-in PCS 200 emulation command set. Before incorporating a PCS 400M into a process using PCS 200 commands the user must insure that the PCS 400M is responding appropriately to each command sent. Be aware that there are some PCS 200 commands which are meaningless to the PCS 400M because of basic differences in the types of instruments, and that there may be other commands not yet enabled in the PCS 400M.

The intent with the PCS 400M design is that it will recognize which syntax is being sent, and respond appropriately to each individual message as it is received. The remainder of the GPIB information in this section contains PCS 200 information that is considered valid for the PCS 400M at this time.

Command Set

The PCS 200 command syntax uses the following:

1. Capital letters represent the exact character transmitted.
2. The following are valid substitutions for the pressure units character '\$':

0	in Hg
1	mBar
2	psi
3	in H2
4	mm Hg
5	kPa
6	mTorr
7	counts (not supported)
8	feet (not supported)
9	current units (no change)
3. The groups of 'n' characters represent numeric input. The number of 'n's represent the number of characters expected. These characters can include the following: '0', '1', '2', '3', '4', '5', '6', '7', '8', '9', '.', '-', '+', and a space. (Note: Some PCS 200 command strings will allow fewer than the specified number of numeric characters to be entered. The PCS 400M will provide similar support.)
4. The 's' character is a place holder for the special function character. This character is ignored by the instrument except when the first character of the command string is an 'F'. Valid 'F' command strings are listed on the next page.
5. PCS 200 emulation commands terminate on the 'X'. The EOI may be sent with 11 character command strings, but is required in command strings with fewer than 11 characters. Carriage returns and linefeeds are not necessary.

Emulation Responses

The PCS 400M will respond to all commands in the language that the command is formatted in. That is, a command preceded by _PCS4 will return an output string in PCS 400M format, and a command sent in PCS 200 language will return a PCS 200 output string.

Table 4.3 - Emulation Responses

Command	Command Description
CX	Control Pressure at last control point and units
C\$nnnnnnnX	Control Pressure at n in units \$
C\$nnnnnnnsX	Control Pressure at n in units \$
D#X	CAL POINT CONTROL MODE NOT SUPPORTED
EX	Clear Error/Clear Service Request
E?X	Return error code and clear error
F\$nnnnnnn1X	Re-initialize; \$,n ignored
F\$nnnnnnn2X	RETURN CAL DATA NOT SUPPORTED
F\$nnnnnnn3X	Return Unit ID string; \$,n ignored
F\$nnnnnnn5X	RETURN QPS TEMPERATURE NOT SUPPORTED
F\$nnnnnnn6X	RETURN NULL METER READING NOT SUPPORTED
F\$nnnnnnn1X	RETURN VACUUM GAUGE READING NOT SUPPORTED
F\$nnnnnnn1X	Return Clock Reading (Time); \$,n ignored
F\$nnnnnnn1X	Return Pressure Control Limits; \$,n ignored
MX	Measure Pressure in current pressure units
M\$X	Measure Pressure in units specified by \$
M\$nnnnnnnX	Measure Pressure in units specified by \$; n ignored
M\$nnnnnnnsX	Measure Pressure in units specified by \$; n,s ignored
Q#X	SEQ FUNCTIONS NOT SUPPORTED
R0X	Return to Standard Output Format
R1X	Re-initialize
R2X	RETURN CAL DATA NOT SUPPORTED
R3X	Return unit ID string
R5X	RETURN QPS TEMPERATURE NOT SUPPORTED
R6X	RETURN NULL METER READING NOT SUPPORTED
R7X	RETURN VACUUM GAUGE READING NOT SUPPORTED
R8X	Return Clock Reading (Time)
R9X	Return Pressure Control Limits (Min and Max)
SX	Standby Mode
S\$X	Standby Mode; \$ ignored
S\$nnnnnnnX	Standby Mode; \$,n ignored
S\$nnnnnnnsX	Standby Mode; \$,n,s ignored
U\$X	Change Units to units specified by \$
VX	Vent Mode in current units
V\$X	Vent Mode in units specified by \$
V\$nnnnnnnX	Vent Mode in units specified by \$; n ignored
V\$nnnnnnnsX	Vent Mode in units specified by \$; n,s ignored
ZX	AUTO RE-ZERO NOT SUPPORTED

Command Reference

The following symbols will be used throughout this section.

- * = Mode of operation as specified below:
 M = MEASURE
 C = CONTROL
 Q = NOT AVAILABLE
 V = VENT
 S = STANDBY

- \$ = Pressure units as specified below:
 0 = in Hg
 1 = mBar
 2 = psi
 3 = in H2O
 4 = mm Hg
 5 = kPa
 6 = mTorr
 7 = NOT AVAILABLE
 8 = NOT AVAILABLE
 9 = Current PCS 400 units (no change)

- # = 1 byte of variable data
- <LF> = Linefeed (ASCII 0A Hex)
- <CR> = Carriage return (ASCII 0D Hex)
- = Space (ASCII 20 Hex)
- . = '.' (ASCII 2E Hex)
- / = '/' (ASCII 2F Hex)
- : = ':' (ASCII 3A Hex)
- ; = ';' (ASCII 3B Hex)
- X = 'X' (ASCII 58 Hex)

Changing the Mode of Operations

Measure

Long Format (11 bytes):

```
1 2 3 4 5 6 7 8 9 10 11
M $ 0 0 0 0 0 0 0 0 X
```

Bytes 3–10 are ignored. Only numeric characters ('.', '+', '-'), are allowed.

Short Format (3 bytes):

```
123
M$X
```

The long and short formats place the PCS in the MEASURE mode in the specified pressure units.

Mini Format (2 bytes):

```
12
MX
```

The mini format places the PCS in the MEASURE mode in the current pressure units.

Control

Long format (11 bytes):

```
1 2 3 4 5 6 7 8 9 10 11
C $ # # # # # # # # X
```

Byte 10 is ignored.

This command places the PCS in the CONTROL mode in the pressure units specified at the pressure specified.

Example: To command 5.2 inHg on a 40 inHg unit, all of the following pressure strings (bytes 3–9) would be acceptable:

```
5.20000
005.200
00005.2
+0005.2
000+5.2
••5.2••
```

Note that the decimal point requires 1 bytes out of seven. Also note that spaces (ASCII 20 Hex) are allowed.

Short Format (4 to 10 bytes):

```
1 2 3 4 5 6 7 8 9 10
C $ # # # # # # # X
```

With this format only the significant digits of the pressure string are required. To command 5.2 inHg as above only '5.2' is required, making the total command string 6 bytes long.

Mini format (2 bytes):

```
1 2
C X
```

This command places the PCS into the CONTROL mode in the current pressure units at the equivalent pressure in the current units to the last commanded control pressure.

Vent

Long format (11 bytes):

```
1 2 3 4 5 6 7 8 9 10 11
V $ 0 0 0 0 0 0 0 0 X
```

Bytes 3–10 are ignored.

Short format (3 bytes):

```
1 2 3
V $ X
```

The long and short formats vent the PCS both internally and externally in the specified pressure units.

Mini format (2 bytes):

```
1 2
V X
```

This command vents the PCS both internally and externally in the current pressure units.

Standby

Long format (11 bytes):

```
1 2 3 4 5 6 7 8 9 10 11
S $ 0 0 0 0 0 0 0 0 X
```

Bytes 3–10 are ignored.

Short format (3 bytes):

```
1 2 3
S $ X
```

Mini format (2 bytes):

```
1 2
S X
```

These commands place the PCS into the STANDBY mode. The long and short formats will change the pressure units when exiting another mode such as MEASURE, CONTROL, or VENT.

Change Units

Short format (3 bytes):

```
1 2 3
U $ X
```

This command changes the pressure units to those specified in byte 2 of the command. See ‘Command Reference’ on the previous page for allowed pressure units.

NOTE: *If the units specified are not supported by the PCS 200 emulation mode an error is generated and the instrument will stay in the current mode of operation.*

Changing Output Format

Unless otherwise specified the output format remains in effect until changed.

NOTE: *The PCS 400M will respond in the PCS 200 output format as long as PCS 200 commands are sent. Once a PCS 400M command is sent, the output format will default to the output specified by out-form 1.*

Return Standard Reading

Long format (11 bytes):

```
1 2 3 4 5 6 7 8 9 10 11
F 0 0 0 0 0 0 0 0 0 X
```

Bytes 2–9 are ignored.

Short format (3 bytes):

```
1 2 3
R 0 X
```

These commands change the PCS output format to the PCS 200 standard format.

Returns a 20 byte string:

```
*$#####<CR><LF>
```

Where:

Byte 1 is the mode of operation.

This byte also determines which portions of the remaining string are valid. All values are set by previous conditions. In the MEASURE and VENT modes all bytes except 11–17 are valid. Bytes 11–17 will represent the last control pressure. In any of the CONTROL modes, the entire string is valid.

Byte 2 is the current pressure units.

Bytes 3–9 is the measured pressure.

This string represents the true measured pressure if byte 10 indicates a stable pressure. The seven characters may include a decimal point with the same fractional digits as displayed on the front panel of the PCS 400M. Leading blanks will be filled with spaces (ASCII 20 Hex).

Byte 10 is the instrument status.

Where ‘S’ indicates a stable pressure: This means the servo system has been within the control window. In the CONTROL mode this indicates the measured pressure is within the window of the commanded control pressure, where the window is set through the front panel or using the appropriate _PCS4 GPIB command.

Where ‘U’ indicates an unstable pressure: This means the servo system is driving to null out all errors or is oscillating more than the window (specified above) around null. In the MEASURE and VENT modes this would indicate the system is seeking a new pressure reading. In the CONTROL modes the ‘U’ indicates the measured reading does not match the commanded control pressure or the servo system may be oscillating and in need of adjustment.

Bytes 11–17 is the control pressure.

This is the current (last used) control pressure. This string may include a decimal point and leading spaces (ASCII 20 Hex).

Byte 18 is the communication status.

This character is an ‘R’ to indicate the PCS 400M is in the REMOTE mode.

The following example indicates the PCS 400M is measuring pressure in inH2O. The current pressure reading is 102.357 but is an unstable reading. The last control pressure entered was 200.000 and the reading was taken over the GPIB port.

M3102.357U200.000R

NOTE: Status byte doesn't support error conditions at this time.

Re-initialize

Long format (11 bytes):

```
1 2 3 4 5 6 7 8 9 10 11
F 0 0 0 0 0 0 0 0 1 X
```

Bytes 2–9 are ignored.

Short format (3 bytes):

```
1 2 3
R 1 X
```

This command will place the PCS 400M in the initializing status similar to that when first powered up. The PCS 400M will not communicate over the GPIB during the initialization. When a user program sends the RE-INITIALIZE command, this shutdown of communications should be anticipated. Otherwise, device timeouts in the user program are likely to occur. This command also causes all the buffers to be cleared and the PCS to go to the LOCAL modes on the GPIB. The output format will be the standard format.

Return Cal Data

This command is not supported by the PCS 400M.

Return Unit ID

Long format (11 bytes):

```
1 2 3 4 5 6 7 8 9 10 11
F 0 0 0 0 0 0 0 0 3 X
```

Bytes 2–9 are ignored.

Short format (3 bytes):

```
1 2 3
R 3 X
```

These commands change the output format to transfer the unit ID data. When the short form is used on the serial port it also causes the data to be output. On the GPIB the output format is valid for one output only. On the serial port the output format remains until changed.

Returns a 20 byte string:

```
*$;•MENSOR•••PCS-400M••V#.###•••###.
#####SN#####<CR><LF>
```

Where:

- Byte 1 is the mode of operation.
- Byte 2 is the current pressure units.
- Bytes 14–20 is the PCS 400M model number.
- Bytes 25–28 is the version number.
- Bytes 31–34 is the pressure range.
- Bytes 36–42 is the pressure units.
 Leading and trailing blanks will be filled with spaces (ASCII 20 Hex).
 For some special pressure ranges the actual location of the data may be different, but will always be within bytes 31–42.
- Bytes 43–51 is the PCS serial number.

Example:

```
M2; MENSOR PCS-400 V1.10 50 PSI
SN2500100<CR><LF>
```

The numeric output format command has no effect on the unit ID format.

Return QPS Temperature

Not supported by the PCS 400M.

Return Null Meter Reading

Not supported by the PCS 400M.

Return Vacuum Gauge Reading

Not supported at this time.

Return Control Limits

Long format (11 bytes):

```
1 2 3 4 5 6 7 8 9 10 11
F 0 0 0 0 0 0 0 0 9 X
```

Bytes 2–9 are ignored.

Short format (3 bytes):

```
1 2 3
R 9 X
```

These commands change the output format to transfer the current control limits in the current pressure units. Format is valid for one output, then returns to the standard output format.

Control limits may not be set over the GPIB.

Returns a 24 byte string:

```
*$;#####<X<#####<CR><LF>
```

Where:

- Byte 1 is the mode of operation.
- Byte 2 is the current pressure units.
- Bytes 4–10 is the low control limit.
- Bytes 14–20 is the high control limit.

Example:

```
C2; 1.0000<X<85.0000 <CR><LF>
```

Return and Clear Error

Short format (3 bytes):

```
1 2 3
E ? X
```

This command sets the output to transmit the error code and description, transmits the data, then clears the error. The format is valid for 1 output only then returns to the standard output format.

Returns a variable length string:

- Byte 1 is 'E'.
- Bytes 2–4 is the decimal value of the error.
- Bytes 7 to end of string is an error message, a carriage return and a linefeed.

RS-232 SERIAL COMMUNICATION

This section of the manual applies to the serial communication capability. Refer to the GPIB portion at the beginning of this section of the manual for additional information relating to commands and responses.

The serial communication port allows the PCS 400M to communicate with computers, terminals and modems (referred to as the host) in RS-232 interface format. Communicating over the serial port does NOT disable the front panel keypad. However, in order to avoid conflicts, front panel entry of commands should be avoided while operating over the bus.

Cable Requirements

RS-232 communications are transmitted over a three conductor, shielded cable terminated in a standard DB9S connector on the PCS 400M end. Figure 4.1 illustrates the proper pin connections for a host to single PCS 400M hook-up.

Setup

Before putting the RS-232 interface into operation the various communication parameters must be selected from the SERIAL setup menu. Refer to the menu tree provided with this manual. Commands must be sent in ASCII format and terminated with the selected termination character. Commands are not case sensitive. Each command returns a response after processing. With 'ECHO ON' the PCS 400M will return the command first, followed by the response. The host must not send another command until the previous response is received.

Parameters

Baud rate: Select the baud rate which matches that of the host. Available PCS 400M baud rates are 300, 1200, 2400, 4800, 9600, and 19200.

Data format: Select the proper data format from the following table:

Table 4.4 – Data Bits Format

Data-Bits	Stop-Bits	Parity
7	1	none
7	1	even
7	2	none
7	2	even
8	1	none
8	1	even
8	2	none
8	2	even

Command Examples

- `_pcs4 func vent<cr>`
Sets PCS 400M to VENT mode.
- `SX<cr>`
Sets PCS 400M to STANDBY.
- `?`
Returns the current output format for PCS 400M or PCS 200, depending on the language of the last command sent.

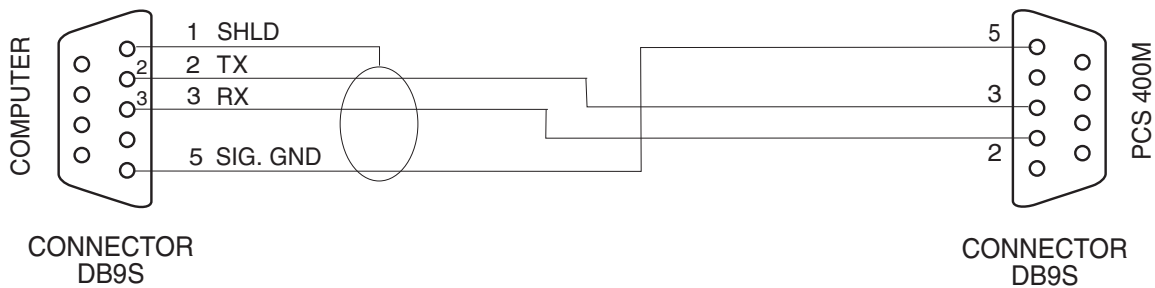

Figure 4.1 - Single Drop Cable

User's Notes:

A large rectangular area filled with a grid of small, evenly spaced dotted lines, intended for the user to write notes. The grid covers most of the page's width and height.

MAINTENANCE

The PCS 400M was designed for maintenance-free operation. User maintenance is not recommended beyond that given in the 'Troubleshooting Guide', and replacement of parts listed in the 'Spare Parts List', both of which follow. If you have questions not covered by this manual the Mensor team is ready to help. Call 1.800.984.4200 (USA only), or 1.512.396.4200 for personal assistance, or at any of the on-line addresses listed in the front of the manual. We are ready to help.

BEYOND THE WARRANTY

Take advantage of Mensor's expert product care. Mensor Corporation provides complete maintenance and calibration services, available after the warranty for a nominal fee. Our service staff is knowledgeable in the innermost details of all of our instruments. We maintain units that are in operation in many different industries and in a variety of applications, and by users with a wide range of requirements. Many of these instruments have been in service for over twenty years, and continue to produce excellent results. Returning your instrument to Mensor for service benefits you in several ways:

1. Our intimate knowledge of the instrument assures you that it will receive expert care.
2. In many cases we can recommend for your consideration, upgrading to the latest enhancements.
3. Servicing our own instruments which are used in "real world" applications keeps us informed as to the most frequent services required. We use this knowledge in our continuing effort to design better and more robust instruments.

PROGRAM DISK REPLACEMENT

In order to replace the system program disk, first remove the power cord from the instrument. Then remove the rear panel by removing the seven screws holding it to the frame. The disk drive is located in the rear upper center of the instrument. The disk is ejected by pressing the button.

Push in the new disk until it locks in place. Replace the rear panel and restore the instrument power. Turning on the instrument will reboot the instrument using the new disk.

MODULE REPLACEMENT

To replace an electrical or a pneumatic module follow these steps:

1. Remove power cord.
2. Remove the top cover by removing the three screws on the top rear.
3. Remove the pressure fittings from rear ports.
4. To remove the pneumatics module, remove the two screws on the rear panel that screw into the pressure manifold, and the two screws under the bottom plate that hold down the module. Disconnect all pneumatic module cables from the electrical module. Then slide the pneumatic module forward slightly to disengage it from the key-hole slots in its base, and lift it out the top of the instrument.
5. To remove the electrical module, remove the cables to the pneumatic module and the front panel, and remove the two screws under the bottom plate that hold down the module. Slide the module forward slightly to disengage the key-hole slots in its base, and lift the module out the top.
6. Reverse the order to replace the module.

ELECTRICAL MODULE

To gain access to the circuit boards inside the electrical module without removing the module, remove the instrument top cover (3 screws), and the left side panel (2 screws). This allows access to the 10 screws that secure the module cover to the module chassis; 4 screws at the top, and 2 screws each at the front, left and right sides. Remove the 2 top center screws and front left screw from the module chassis. Loosen the remaining 7 screws, leaving them threaded into the module chassis. Lift module cover up in the front and slide towards you.

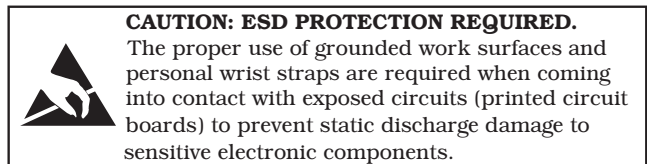

All of the circuit boards in the module are compatible with standard IBM format Personal Computers (PC's). Most are purchased from various manufacturers; they may differ in appearance and position from one unit to the next but their functionality remains the same. The exceptions are that the Solenoid Driver and PLA boards are proprietary, designed and assembled by Mensor.

TROUBLESHOOTING GUIDE

The following information was developed from our experience at the factory in producing and servicing the PCS 400M. It is provided to assist the user in locating the cause of symptoms that might be encountered and corrected on site. The circled numbers in the table below refer to the key numbers in fig. 5.1, which are used to indicate approximate locations.

NOTE: Fig 5.1 reflects the current configuration for a standard PCS 400M with two pressure channels plus a BRT. Older units and other options may be configured differently.

CAUTION: ESD PROTECTION REQUIRED!
 The proper use of grounded work surfaces and personal wrist straps are required when coming into contact with exposed circuits (printed circuit boards) to prevent static discharge damage to sensitive electronic components.



CAUTION: PREVENT POWER SURGES!
 Shut off power to the PCS 400M before connecting or disconnecting circuit boards and connectors. With system power on the voltage spikes generated by such activity can damage sensitive electronic components.



- NOTES:**
- 1. The plug-in boards may be arranged in a different order than illustrated.
 - 2. The CMOS Battery is located on the CPU Board in some systems.

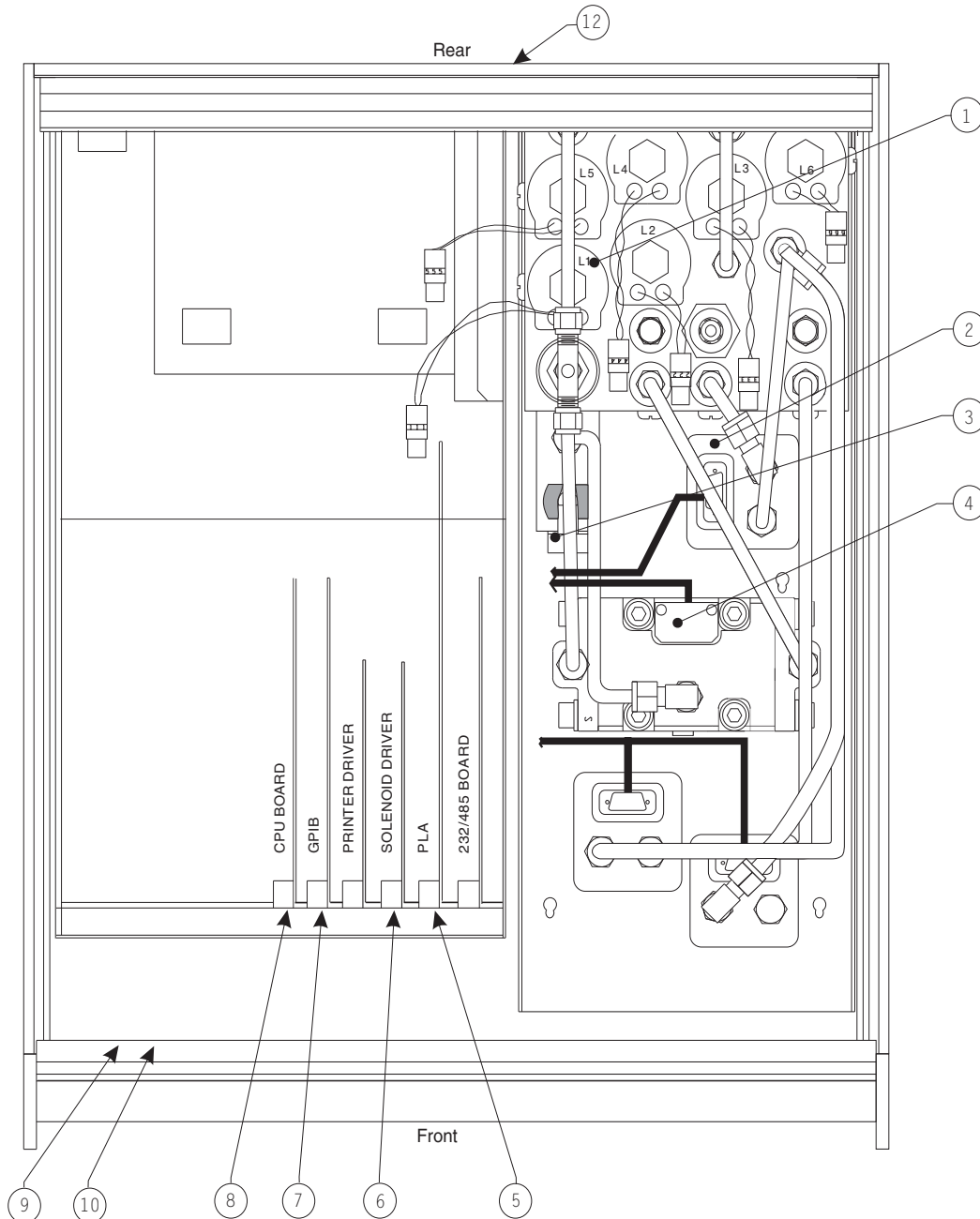

Figure 5.1 - Chassis Assembly-Top View

Error Symptoms and Solutions

Table 5.1 - Error Symptoms and Solutions

	Symptoms and Clues	Possible Cause	Try This
1	<p>SYSTEM DOES NOT BOOT; DISPLAY IS BLANK</p> <p>CLUE: The display is powered by five volts from the electrical module through the display connector. If the five volts is present, the cursor will appear on the upper left of the display.</p>	<p>The three pin display connector ⑩ or its wires may be disconnected from the front panel or from the power connector inside the electrical module.</p> <p>-----</p> <p>The power supply is shorted out.</p> <p>-----</p> <p>The power supply in the electrical module has failed.</p>	<p>Reconnect connector or wires.</p> <p>-----</p> <p>Verify there are no loose parts or circuit cards inside the electrical module.</p> <p>-----</p> <p>Return the PCS 400M or the electrical module to Mensor for repair.</p>
2	<p>SYSTEM DOES NOT BOOT; DISPLAY HAS A CURSOR IN UPPER LEFT CORNER</p> <p>CLUE: The display is receiving power but the PCS 400M is not loading and starting its program.</p>	<p>Circuit cards have popped out of their connectors. The three pin display connector ⑩ or its wires may be disconnected from the front panel or from the COM2 port inside the electrical module.</p> <p>-----</p> <p>The CPU board has lost its battery backed CMOS data (BIOS); The battery may be discharged. See Figure 5.1, Note 2.</p> <p>-----</p> <p>Program disk not loaded properly.</p>	<p>Verify there are no loose parts or circuit cards inside the electrical module.</p> <p>-----</p> <p>Remove rear panel and verify that the program disk is fully seated in the disk drive ⑫.</p>
3	<p>SYSTEM DOES NOT BOOT; DISPLAY SHOWS INITIALIZATION SCREEN</p> <p>CLUE: The PCS 400M is loading its program correctly but it can't communicate with the primary transducer in the pneumatics module.</p>	<p>The cable connecting the electrical module to the transducer is disconnected or shorted.</p> <p>-----</p> <p>The calibration of the main transducer has been corrupted.</p>	<p>Check the 50 pin connector ⑤ on the electrical module. Check the 25 pin connector ② on the top of the main transducer. Make sure the other connectors on the cable which goes to the main transducer are not shorted against something.</p> <p>-----</p> <p>Contact Mensor for help in determining if this is the problem.</p>

Continued on next page...

(Table 5.1 continued...)

	Symptoms and Clues	Possible Cause	Try This
4	<p>SYSTEM DOES NOT CONTROL AT COMMANDED SET POINT</p> <p>CLUE: The PCS 400M requires an input pressure higher than the control output set point, or pneumatics section is working improperly.</p>	<p>The source pressure is not high enough.</p> <p>-----</p> <p>The cable connecting the electrical module to the regulator is disconnected.</p> <p>-----</p> <p>The solenoid valves are not opening to let pressure into or out of the control module.</p> <p>-----</p> <p>PCS 400M has a pneumatic leak.</p>	<p>Apply source pressure 10 psi (or 10%) greater than the commanded set point.</p> <p>-----</p> <p>Check the 9-pin connector ⑥ on the electrical module and the pcb connector ④ on top of the regulator. Make sure the regulator connector is not shorted against something.</p> <p>-----</p> <p>Run the solenoid valve test to verify that all of the valves are working.</p> <p>CAUTION: HIGH PRESSURES COULD BE PRESENT AT THE GAUGE OUTPUT DURING THE TEST.</p> <p>-----</p> <p>See next section.</p>
5	<p>SYSTEM HAS A PNEUMATIC LEAK</p> <p>CLUE: Possible sources for leaks are solenoids, plumbing, or relief valves.</p>	<p>Because of the extreme resolution of the PCS 400M, very small temperature changes on trapped volumes of gas will appear as changes in pressure. The PCS 400M will control small leaks with no effect on any control parameters. The built-in leak diagnostics are designed to help troubleshoot problems but not return absolute numbers.</p>	<p>Run internal leak test and system leak test to determine if leak is inside unit or external. Most internal leaks appear at solenoid valves, relief valves and fittings.</p>
6	<p>SYSTEM DOES NOT RESPOND FROM THE FRONT PANEL KEYPAD</p> <p>CLUE: Signals are not being transferred from the front panel keypad to the electrical module.</p>	<p>The keypad cable is disconnected at the front panel ⑨ or at the electrical module.</p>	<p>Re-connect the cable.</p>

Continued on next page...

(Table 5.1 continued...)

	Symptoms and Clues	Possible Cause	Try This
7	<p>SYSTEM UNABLE TO COMMUNICATE OVER THE GPIB</p> <p>CLUE: Signals are not being transferred from the GPIB board to the rear panel of the PCS 400M.</p>	<p>The GPIB address is set incorrectly.</p> <p>-----</p> <p>GPIB cable is disconnected at the front of the electrical module ⑦.</p> <p>-----</p> <p>The GPIB card is not properly seated in the electrical module.</p>	<p>Check and reset the GPIB parameters from the front panel keys.</p> <p>-----</p> <p>Re-connect the cable.</p> <p>-----</p> <p>Re-seat the GPIB card into its mating connector.</p>
8	<p>SYSTEM UNABLE TO COMMUNICATE OVER THE RS-232 PORT</p> <p>CLUE: Signals are not being transferred from the CPU board in the electrical module to the rear panel.</p>	<p>The RS-232 parameters are not set up properly</p> <p>-----</p> <p>The RS-232 cable is disconnected from the CPU board ⑧.</p> <p>-----</p> <p>CPU board not seated.</p>	<p>Check and reset serial parameters from the front panel keys.</p> <p>-----</p> <p>Re-connect the cable. The red conductor connects to pin 1, COM1.</p> <p>-----</p> <p>Re-seat CPU board into its connector.</p>
9	<p>INACCURATE OR NO RESPONSE TO THE SOURCE PRESSURE TEST</p> <p>CLUE: The auxiliary transducer on the pneumatics module measures the source pressure by opening only the coarse supply solenoid. Its calibrated analog output is read by the electrical module and converted to pressure.</p>	<p>Transducer cable is disconnected on the auxiliary transducer board ③ or at the 50 pin connector ⑤ on the electrical module.</p> <p>-----</p> <p>The coarse supply solenoid ① is not connected or not opening.</p>	<p>Re-connect the cable.</p> <p>-----</p> <p>Run the solenoid test to determine if the coarse supply solenoid valve is operating.</p>
10	<p>TOP LINE OF DISPLAY SHOWS ZEROS DURING BAROMETRIC REFERENCE CALIBRATION, BUT SHOWS BAROMETRIC PRESSURE WHEN THE BAROMETRIC SENSOR IS MADE ACTIVE.</p> <p>CLUE: The PCS 400M looks for a specific transducer address during barometric calibration.</p>	<p>Either the address on the Barometric Reference Sensor, or the interrupt is improperly set.</p>	<p>Check that the address of the Barometric Reference Sensor is set to address 2 (W2) with no interrupt (no jumper) on W8 or W9.</p>

SPARE PARTS LIST

Below is a table showing PCS 400M spare parts that can be ordered from Mensor.

Table 5.2 – Spare Parts

Part Description	Part Number	Comments
Miscellaneous:		
Manual	0017174001	
Fuses*	4100111150	
Power Cord	4000400002	
Rubber Feet	3201300001	
Front Panel Assembly:		
Display Module	0017185001	
	5000400012	
Electrical Module:		
	0014142002	
GPIB Board	4904000015	
Solenoid Driver Board	0014172001	
PLA Board	0014293001	
Floppy Drive	4907000002	
Power Supply (modified)	4901000024	
RS232/485 Board	4904000051	
Pneumatics Module:		See Note below
HP Solenoid Valve Assembly (modified)*	0014209002	
HP Solenoid Valve Assembly (unmodified)*	0012347012	
LP Solenoid Valve Assembly (modified)*	0014209001	
LP Solenoid Valve Assembly (unmodified)*	0012347011	
Reed Valve Regulator Top Cap Assembly	0014266001	High Pressure
Reed Valve Regulator Top Cap Assembly	0014266002	Low Pressure
Pneumatic Filter Elements*	6001202006	
7/16-20 to 1/8" NPT female fittings	6000802004	
O-ring seals for all 7/16-20 fittings*	4250010020	
7/16-20 to 1/4" Swagelok	6000604019	
7/16-20 to 1/4" NPT female fittings	0012688001	

*Recommended Spare Parts

Note: Requires specific range and software version number. Contact Mensor for exact replacement.

CALIBRATION

The PCS 400M automatically adjusts the pressure reading for the effects of temperature and non-linearity within the calibrated temperature range of 15-45°C. The process is referred to as dynamic compensation because each reading is so adjusted before it is output to the display or to a communication bus. Thus, a calibrated PCS 400M operated within its temperature band, and with proper zero and span adjustments, will provide accurate pressure measurements.

The PCS 400M should have the span verified periodically on each of its transducers to insure their stability. Initially, the recommended period between calibrations is 180 days. This period may be extended as confidence is gained in the span stability.

CALIBRATION ENVIRONMENT

For maximum accuracy, the PCS 400M should be allowed to warm up in the STANDBY mode for a minimum of 45 minutes in an ambient temperature which is in the specified calibration range, and stable. In addition the instrument should be at rest on a stable platform which is free of excessive vibration and shock.

PRESSURE STANDARD

Mensor recommends the use of appropriately accurate primary pressure standards when calibrating this instrument. Such standards should be sufficient so that when the techniques of the ISO Guide to the expression of Uncertainty in Measurement (GUM) are applied, the instrument meets its accuracy statements as required by ANSI/NCSL Z540, or other applicable standards.

CALIBRATION MEDIUM

The recommended calibration medium is dry nitrogen or clean dry instrument air. For low pressure ranges (< 20 psi), head pressure differences between the standard and the PCS 400M can cause errors. See 'Head Pressure Correction' in the Appendix.

CALIBRATION PROCEDURES

For convenience, the procedures for zero and span adjustment for a gauge pressure instrument are presented first followed by the procedures for an absolute pressure instrument. Figure 6.1 (Gauge Calibration Setup) and figure 6.2 (Absolute Calibration Setup) illustrate typical setups for either local or remote calibration. In the figures the additional equipment required for remote calibration are shown as optional.

In both of the calibration setup illustrations the "Pressure Standard" is normally a deadweight test instrument, and the "volume controller" refers to a hand operated variable-volume pressure vernier device. A diaphragm type vacuum gauge is recommended over the gauge tube type of vacuum sensor for calibrating sub-atmospheric pressures. Where a vacuum source is required a minimum capacity of 21 liters per minute is recommended.

NOTES:

1. *The recommended units for making zero or span adjustments are psi. Other engineering units might add a small roundoff error.*
2. *When this instrument was calibrated at the factory the zero and span corrections were stored in memory. If the zero or span values are changed at the front panel, or over the remote bus, the new values immediately displace the factory values in memory. It is recommended that a permanent record be maintained of the 'as received' values, as well as the values that result from each subsequent zero and span update.*
3. *If the PCS 400M uses more than one pressure transducer in the MEASURE mode, then the transducer to be calibrated must be selected as the "active" transducer. Use the [LIMITS], [ACTIVE XDUCER] functions from the keypad or 'PCS4 XDUCER digits' command over the GPIB to select the transducer that is to be "active" for calibration. (digits) is the number of the sensor to be active.*

CALIBRATING A GAUGE PRESSURE INSTRUMENT



WARNING: POSSIBLE INJURY!
The tubing, valves and other apparatus attached to the gauge must be adequate for the maximum pressure which will be applied, otherwise physical injury to the operator or bystanders is possible.

To set zero over the GPIB, send the command ‘_PCS4 CAL ZERO *value*’, where *value* is the true pressure, (0).

NOTE: *The zero adjustment can be used as a tare offset by adjusting the display to the required tare value. The maximum zero offset is approximately ± 16 psi.*

With the PCS 400M and any remote transducers connected to the Gauge Calibration Setup, vent the pressure to atmosphere, and set the instrument to the MEASURE mode.

The current calibration of the active sensor can now be checked at a number of pressure points from zero to full scale. If recalibration is needed, proceed with the following.

Setting the Sensor Zero

With the instrument in the VENT mode and the pressure vented to atmosphere, from the keypad push: [2nd], [CAL], [=] enter password [=] [=]. At the SENSOR ZERO prompt, type in the true differential pressure, [0], and [=] to enter the reading into memory. Press [CE]. The display should now indicate the zero pressure reading.

Setting the Sensor Span

Close the vent and apply a known pressure equal to or near the span of the sensor.

From the keypad, push [2nd], [CAL], [+], [=] enter password [=] [=]. At the SENSOR SPAN prompt, type in the true pressure and then [=] to enter the reading. The range of span adjustment available is ± 0.1% of the transducer full scale value. Press [CE]. The display should now indicate the new true pressure.

From the GPIB, send the command ‘_PCS4 CAL SPAN *value*’, where *value* is the true pressure applied to the sensor. The recalibration is now complete.

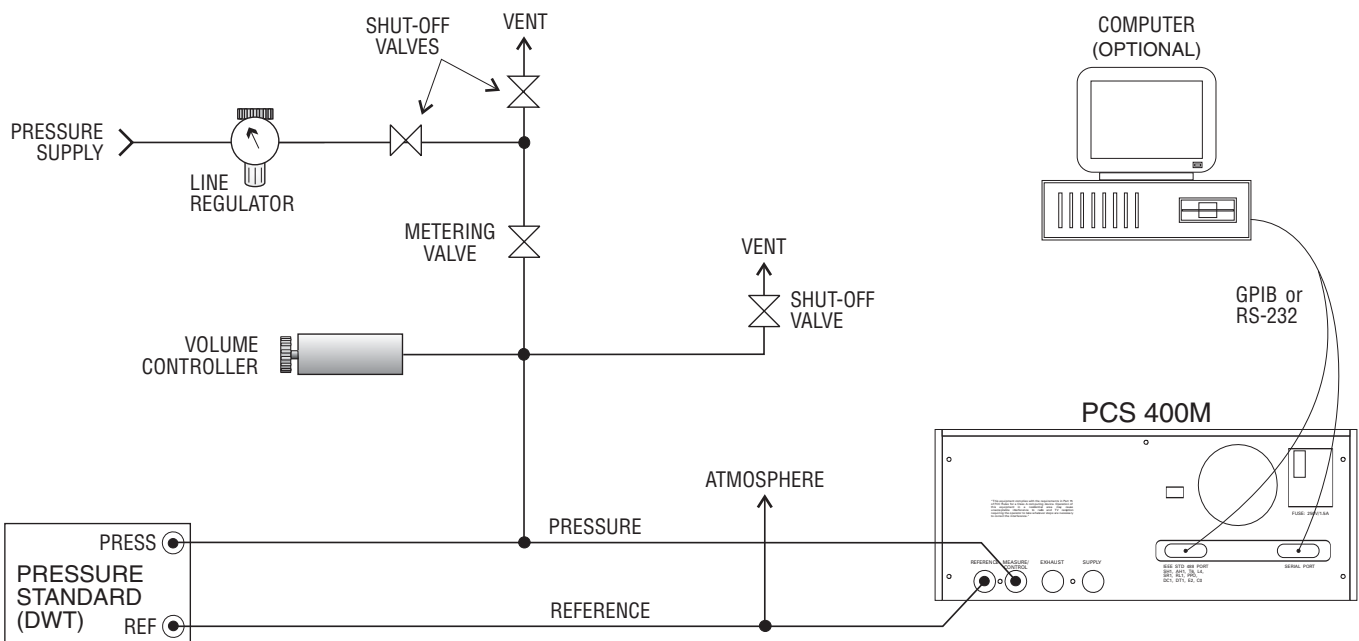



Figure 6.1 - Calibration Setup for Gauge Pressure

CALIBRATING AN ABSOLUTE PRESSURE INSTRUMENT



WARNING: POSSIBLE INJURY!
The tubing, valves and other apparatus attached to the gauge must be adequate for the maximum pressure which will be applied, otherwise physical injury to the operator or bystanders is possible.

With the PCS 400M and any remote transducers connected to the Absolute Calibration Setup, close the vent and connect the vacuum pump to the MEASURE/CONTROL port. Set the instrument to the MEASURE mode.

Evacuate the transducer to a low pressure that will still maintain a viscous flow. This can be achieved at a pressure ≥ 40 pascal (300 millitorr). (At pressures lower than this the actual pressure at any particular point in the system is questionable.) Allow from five to ten minutes for the target pressure to stabilize, then convert the pascal reading to an equivalent instrument reading for the active measurement units. Pascal conversion factors are provided in table 9.3 in the Appendix.

The current calibration of the active sensor can now be checked at a number of pressure points from zero to full scale. If recalibration is needed, proceed with the following.

Setting the Sensor Zero

With the instrument in the MEASURE mode and the pressure ≥ 40 pascal (300 millitorr), convert the pascal reading into the current displayed engineering units. From the keypad push: [2nd], [CAL], [=] enter password [=] [=]. At the SENSOR OFFSET prompt, type in the true absolute pressure, [XXX], and [=] to enter the reading into memory. Press [CE]. The display should now indicate the current “zero” pressure reading.

To set zero over the GPIB, send the command ‘_PCS4 CAL ZERO value’, where value is the true pressure, (XXX).

NOTES:

1. The zero adjustment can be used as a tare offset by adjusting the display to the required tare value. The maximum zero offset is approximately ± 16 psi.
2. Rather than convert the millitorr vacuum gauge reading to the current engineering units for setting zero, the current units can be changed to MICRON HG @ 0C or MTORR in the METRIC menu. Then enter the millitorr reading to set zero, and then change back to the normal engineering units for setting the span later.

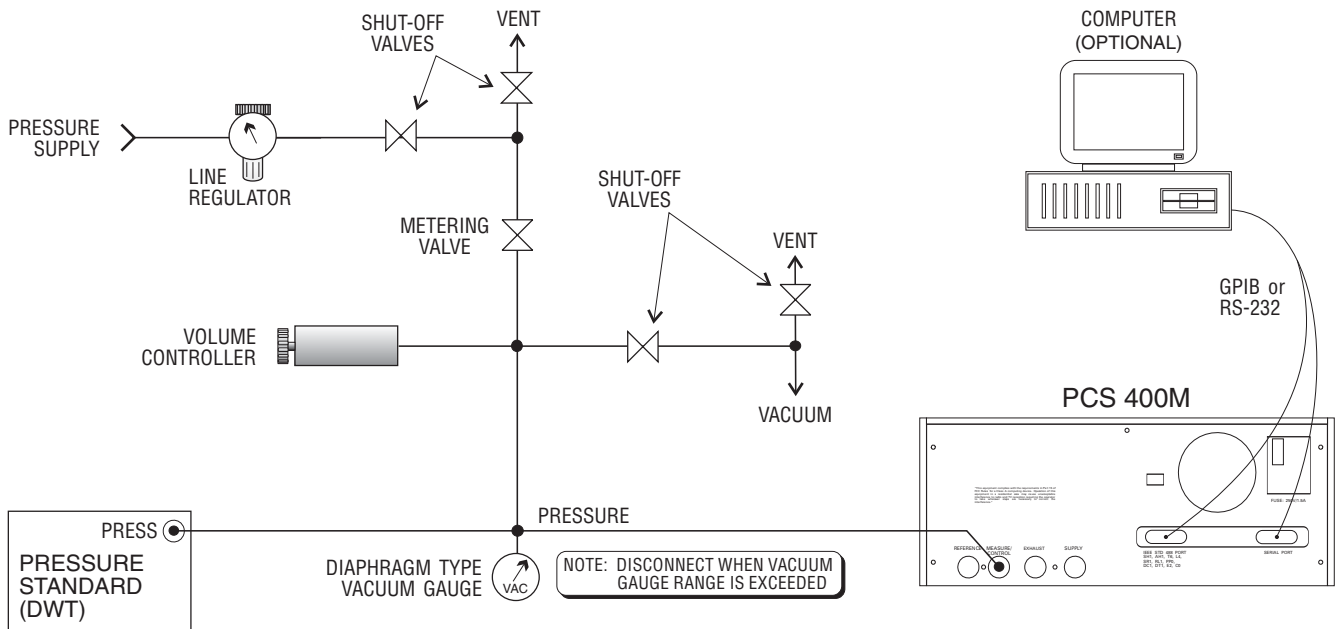

Figure 6.2 - Calibration Setup for Absolute Pressure

Setting the Sensor Span

Apply a known absolute pressure equal to or near the span of the sensor. Do not attempt to set span while at or near zero.

From the keypad, push [2nd], [CAL], [+], [=] enter password [=] [=]. At the SENSOR SPAN prompt, type in the true pressure and then [=] to enter the reading. The range of span adjustment available is $\pm 0.1\%$ of the transducer full scale value. Press [CE]. The display should now indicate the new true pressure.

From the GPIB, send the command '_PCS4 CAL SPAN *value*', where *value* is the true pressure applied to the sensor. The recalibration is now complete.

SPECIFICATIONS

Accuracy specifications presented herein are obtained by comparison with primary standards traceable to the National Institute of Technology (NIST). These specifications are obtained in accordance with the ISO *Guide to the Expression of Uncertainty in Measurement* (GUM). Mensor also adheres to ANSI/NCSL-Z540. If there is an exception to the requirements and recommendations of Z540 during a calibration the exception is noted on the individual calibration certificate.

Mensor reserves the right to change these specifications without notice.

MEASURE SPECIFICATIONS

Accuracy

0.010% FS including linearity, hysteresis, repeatability and temperature after zeroing at the operating temperature over the calibration interval. Optional 0.025% FS accuracy available.

Precision

0.003% FS.

Calibration Stability

0.010% FS for 180 days after re-zeroing. Optional 0.025% FS accuracy instruments are 0.025% for 180 days after re-zeroing.

Pressure Ranges

Standard Ranges:

Psia: 0-5 to 0-2,000 max.

Psig: 0-0.36 to 0-2,000 max.

Bi-directional, Vacuum:

-0.36 to +0.36 min.,

-atm to 2,000 max.

Measurement Units

Refer to Table 9.1 in the *Appendix* section.

Resolution

Up to 1 PPM.

Calibration Adjustments

Zero may be offset up to ± 16 psi either from the front panel, or over a remote bus.

Span may be adjusted up to $\pm 0.1\%$ of the sensor full scale value, either from the front panel, or over a remote bus.

Calibration Interval

Initially, the recommended period between calibrations is 180 days. This period may be extended as confidence is gained in the span stability.

Measurement Filter

The measurement filter is a user adjustable filter that takes the specified percentage of the previous reading plus $(1 - [\text{filter \% divided by } 100]) \times$ the new reading. If two consecutive readings are further apart than the user-specified filter window, the previous reading is reset to the new reading value.

CONTROL SPECIFICATIONS

External Pressure Requirements

Reference Pressure: Atmosphere for gauge models. Permanent vacuum for absolute models.

Source Pressure (for ranges >5 psi): Instrument air or dry nitrogen at pressure equal to FS plus 10 psi or 110% of FS. Accurate external regulation is not required.

Exhaust Pressure: Atmospheric exhaust for gauge pressure control above 0.05 psig. Vacuum source required for gauge control below 0.05 psig and absolute pressure control. A vacuum pump is recommended for gauge control of positive pressures below 0.25 psig.

External Volume Requirements

Up to 1/2 liter.

Stability of Controlled Pressure

> 2 psi: $\pm 0.004\%$ FS

< 2 psi: $\pm 0.008\%$ FS

Minimum Control Pressure

Gauge and Absolute Instruments (positive pressure): Exhaust pressure plus 0.05% FS, or exhaust pressure plus 0.025 psia, whichever is greater.

Pressure Control Rates

A pressure rate limit may be selected to limit the maximum slew speed between selected control points. Minimum and maximum slew speed is dependent upon pressure range per the following table:

Table 7.1 – Min/Max Slew Speed

Full Scale (FS)	Minimum	Maximum
> 100 psi	.025 psi/sec	10 psi/sec
≤ 100 psi	.0025 psi/sec	1 psi/sec
≤ 5 psi	.00025 psi/sec	.1 psi/sec

Control Time

When controlling: For the output pressure to be in the stable window, 55 seconds is typical between any two pressure points from 0.5% FS above the exhaust pressure to full scale with a 1/2 liter volume. A larger volume can lengthen this time. The time will also be longer for absolute pressures below 0.5 psia.

Overshoot

NORMAL Mode: 1% FS maximum.
RATE Mode: Typically less than 0.004% FS. This figure may be larger in low absolute pressure applications, and is somewhat dependent on the range, vacuum pump efficiency and overall system volume.

Supply Consumption

Less than 2.5 scfh at static pressure. Additional consumption caused by pressure slewing cannot be specified due to unknown volumes, frequency of pressure changes, and extent of pressure changes.

GENERAL SPECIFICATIONS

Size

(See Figure 7.1 - Dimensional Outline)
Width: 17.05 inches (43.31 cm)
 19.00 inches (48.26 cm) with rack adapter
Height: 6.97 inches (17.70 cm)
Length: 20.00 inches (51 cm) without fittings

Weight

43.00 lbs (19.5 kg) single range less rack adapter
 4.00 lbs (1.8 kg) rack adapter kit

Mounting

Standard: Table model.
Optional: Rack Mount Kit with slides is available for mounting in 19 inch rack.

Power Input Requirements

90 to 264 VAC, 50 to 60 Hz autoswitching, 175VA max.

Power Cord: Detachable, 3-wire 117V.

Fuses

Two each, 1.5A, 117V. Accessible without opening unit.

Pneumatic Interfaces

7/16 - 20 SAE/MS (female).
 (1/8" female NPT adapters provided.)

Particle Filters

Internal replaceable 30 micron filters are in the SOURCE and MEASURE/CONTROL ports, and a 40 micron filter in the VENT port.

Overpressure Protection

Measure/Control Port: This port has a relief valve set at 5% to 10% above the pressure range of each internal sensor as referenced to atmosphere.

Compensated Temperature Range

15°C to 45°C.

Operating Temperature Range

0°C to 50°C. Note: This is not the compensated temperature range.

Storage Temperature Range

-20°C to 70°C.

Local User Interfaces

Keypad: 16 dual-function keys.
Display: Vacuum fluorescent, 2 lines of 40 characters.

Remote User Interfaces

IEEE-488-STD-1978 and RS-232.

Warm-up

Approx. 45 minutes to achieve full accuracy.

Response Time

Less than 0.2 seconds for FS step with no digital filtering.

Orientation Effects

Negligible effect on span, linearity and zero in any attitude.

Pressure Media

Clean, dry, non-corrosive gases, no oxygen.

Shock/Vibration

2 gravities max. for 10 minutes, per MIL-T-28800.

Operating Environment

Humidity: 5% to 95% RH non-condensing.

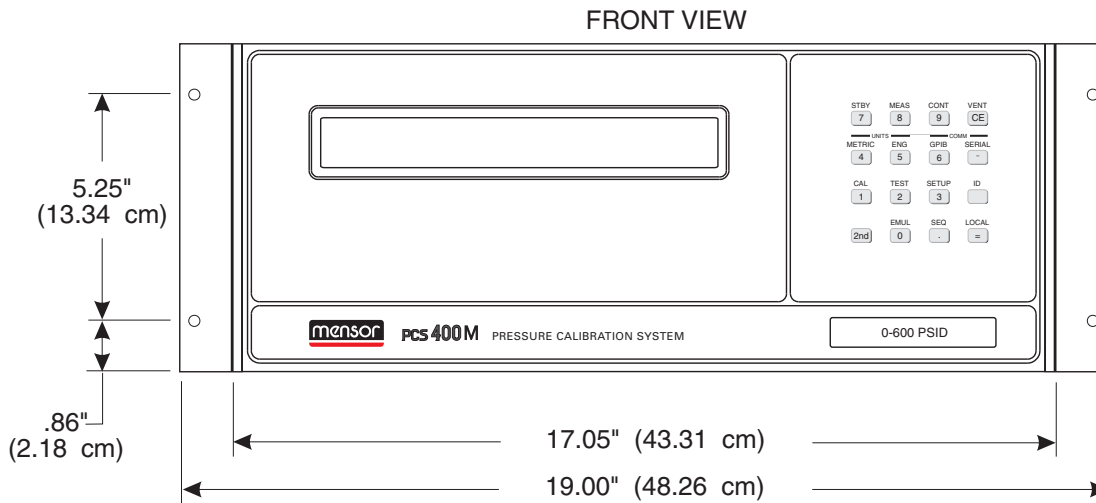

Overall width with Rack Mount Flanges attached.

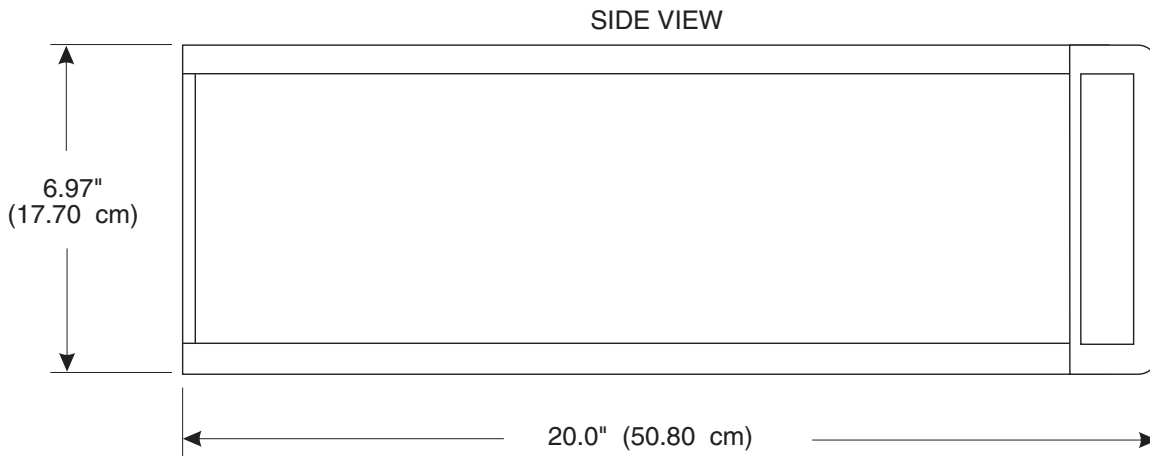

Add 0.45 inches (1.14 cm) to height with feet attached.

Figure 7.1 - Dimensional Outline

User's Notes:

A large grid area for user notes, consisting of a 20x20 grid of small squares. The grid is formed by dotted lines and is intended for the user to provide additional information or notes.

OPTIONS

This section lists most of the options which have been designed for the PCS 400M. Many of these originated in response to customer requests for special features to meet specific requirements. Users might consider letting the factory install one or more of these options into their instrument, or even request a special feature not listed here. Mensor welcomes the opportunity to quote on such requests. The cost of adding an enhancement frequently will amortize itself in a very short time because of improved process efficiency.

Although all of the options listed are currently available, some options are mutually exclusive, and cannot be combined into the same instrument. Contact Mensor Marketing if you have questions or special requirements.

LIST OF OPTIONS

1 - Rack Mount Kit	8-2
2 - Transport Case	8-4
3 - Multiple Range Pneumatics Kit	8-5
3a - Barometric Reference Transducer	8-5
4 - Bi-Directional Pressure Control	8-6
5 - Pressure Emulation Modes	8-6
5a - Gauge Transducers (Abs Emulation) without BRT	8-6
5b - Gauge Transducers (Abs & Vac Emulation) with BRT	8-7
5c - Absolute Transducers (Gauge Emulation) with BRT	8-7
6 - Low Pressure External Plumbing	8-9

1 – RACK MOUNT KIT

The PCS 400M is easily mounted into a 7 inch opening of a 19 inch wide rack. The rack used should satisfy the dimensional requirements shown below. It should be free of vibration and excessive heat, as noted below.

After all equipment is installed, check to see that the temperature inside the rack does not exceed 38°C. If it does, additional rack spacing and/or ventilation must be considered.

Install the chassis slide, being sure to allow the proper spacing above and below the PCS 400M. A PCS 400M with the rack mount option is then installed from the front of the rack. Before installing the PCS 400M, remove the four feet from the bottom of the instrument. Slide the PCS 400M all the way into position and secure the instrument to the rack before connecting power and pneumatic lines to the rear panel.

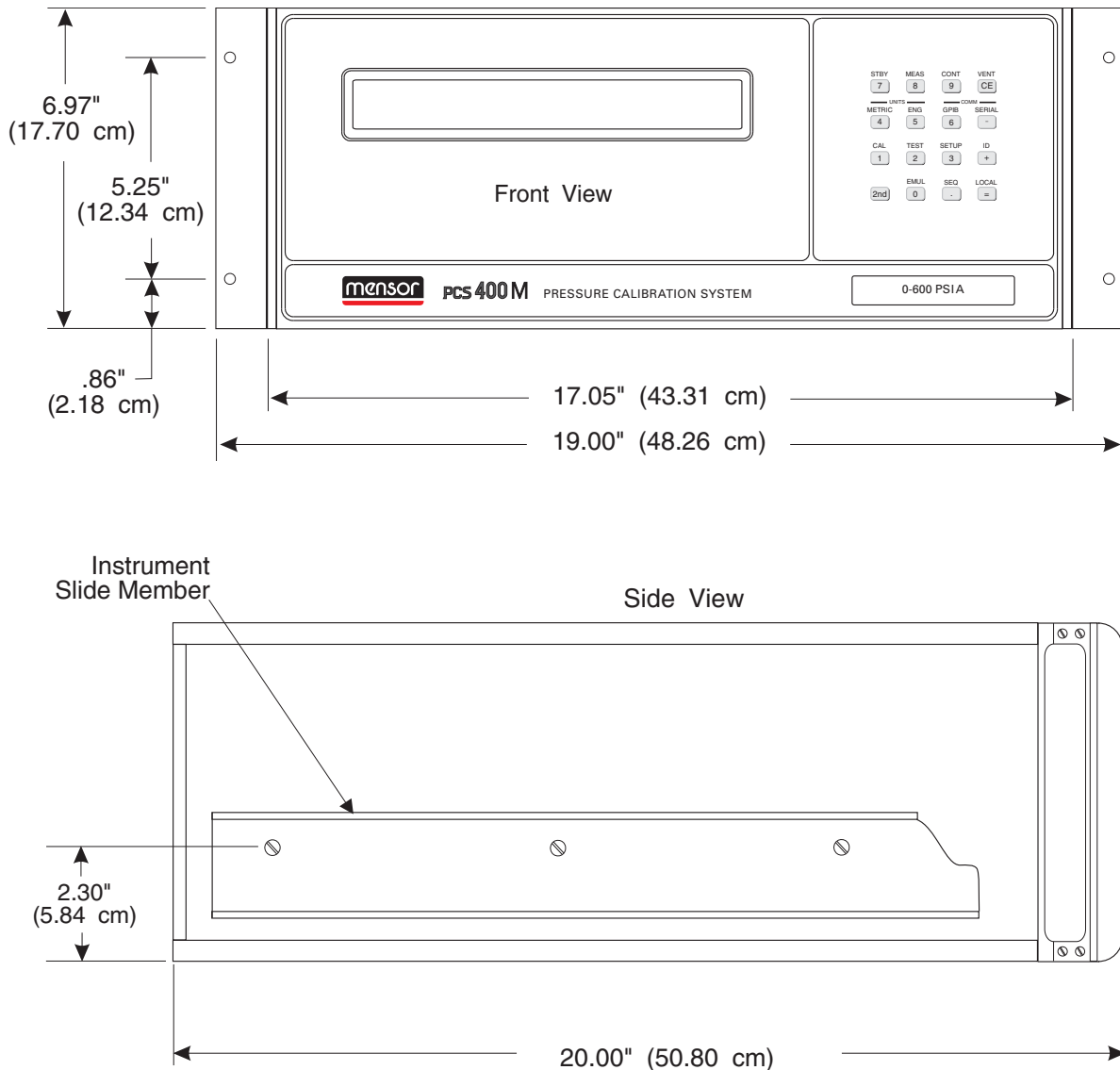
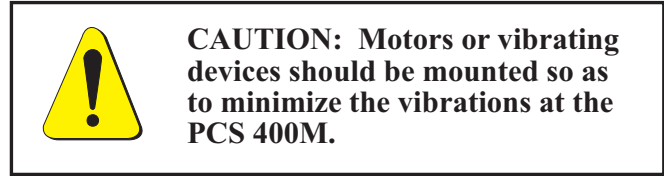

Figure 8.1 - Rack Mount Dimensions

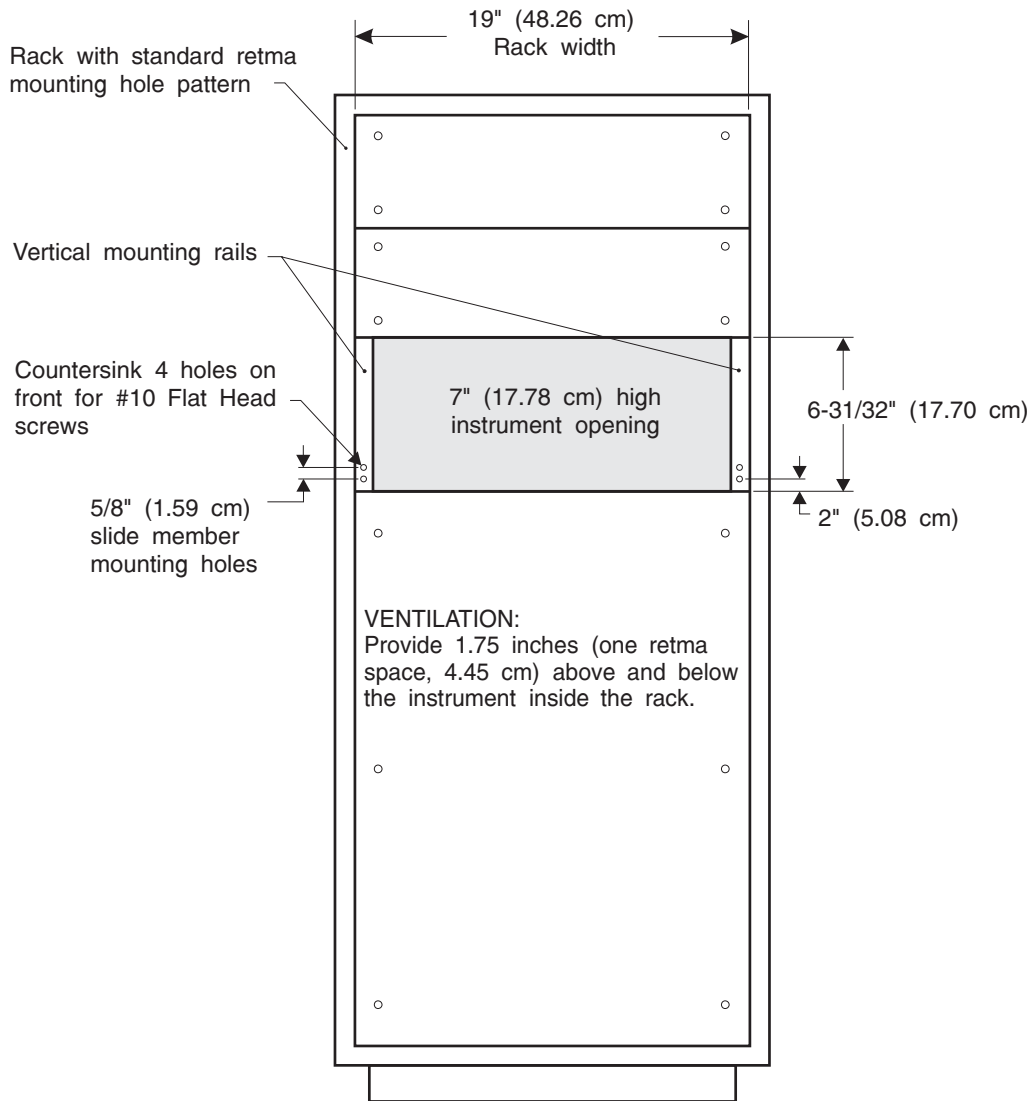

Figure 8.2 - Rack Specifications

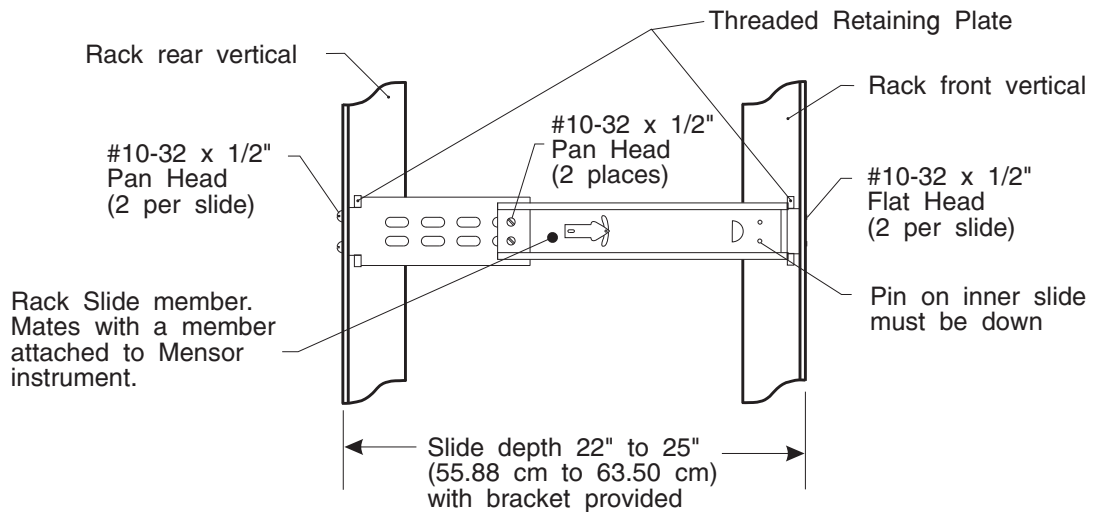

Figure 8.3 - Slide Specifications

2 – TRANSPORT CASE

A wheeled Transport Case is available suitable for moving the PCS 400M between sites, or as an air-freight (or other) shipping container. The case is constructed of a high impact plastic with a black exterior. It includes two keys, locks, a piano hinge, an anodized interlocking tongue and groove opening, various nickel-chrome and stainless steel fixtures, a vinyl satchel style handle and a retractable pull-out handle. The interior is filled with high density polyurethane foam with a die-cut cavity to cradle the instrument with fitting adapters in place, and an additional cavity to store related accessories. Rugged and weather resistant, the case makes an attractive, practical shipping and moving container. The case weighs approximately 29 pounds (13.15 kg) unloaded, and can support a load of up to 150 pounds (68.04 kg). Nominal dimensions are 15 inches by 24 inches by 26 inches (38.10 cm x 60.96 cm x 66.04).

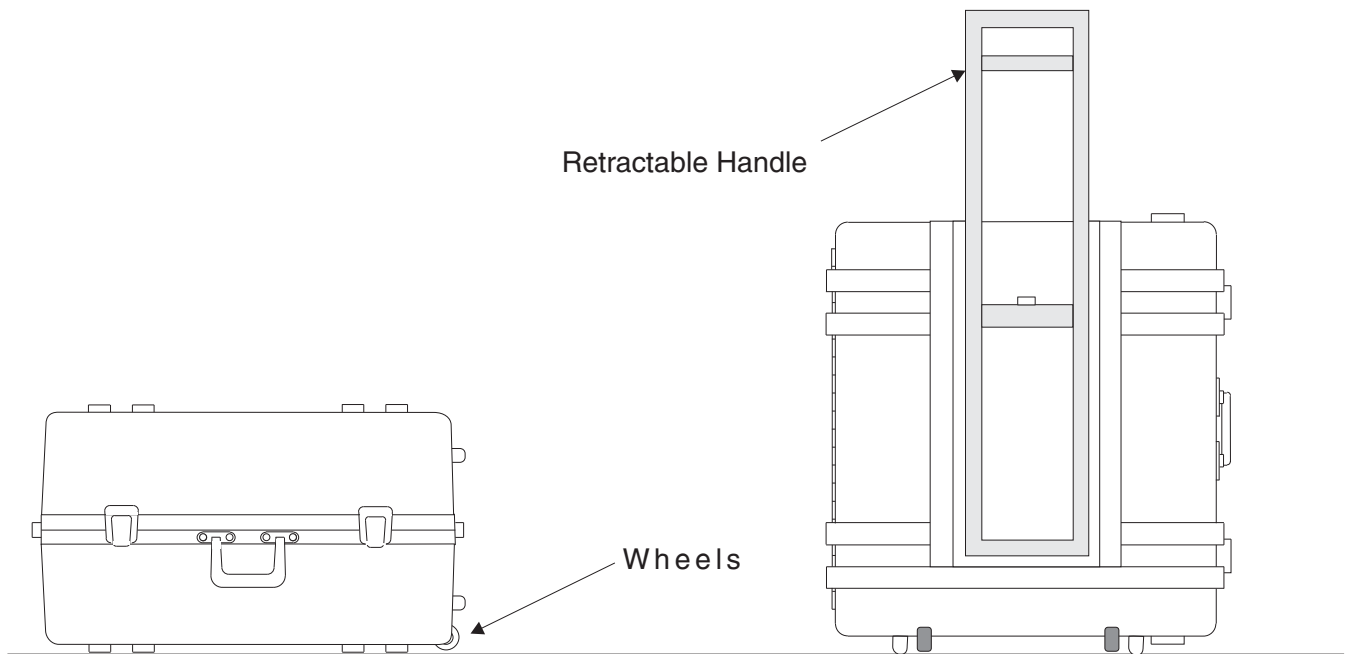

Figure 8.4 - Transport Case

3 – MULTIPLE RANGE PNEUMATICS KIT

The pneumatic module can accommodate one, two or three internal transducers. All three can be of a common mode, or a mix of gauge and absolute mode transducers. For example, one frequent configuration is a high and a low pressure primary and secondary transducer and a Barometric Reference (absolute) Transducer for the third. This arrangement provides the user with better accuracy for a second pressure range and allows a fast, convenient means for setting absolute Zero on those two transducers. This arrangement, and other multi-range configurations, are shown by the pneumatic schematics in the *Appendix*, figures 9.3 through 9.6. The software provides the user with the capability to set the system to either AUTORANGE for automatic best resolution, or to RANGE HOLD to lock onto a selected transducer. AUTORANGE and RANGE HOLD are explained in the *Local Operation* and *Remote Operation* sections of the manual. The use of the Barometric Reference Transducer is explained under Option 3a which follows. There are some design constraints on a multiple range PCS 400M. Contact Mensor to discuss the feasibility of your particular multi-range requirements.

3a – Barometric Reference Transducer

A Barometric Reference Transducer is a special internal high accuracy barometric range transducer. This special transducer will always have transducer address 02. Normally it is open to atmosphere only, and is pneumatically isolated from the system. For some special applications it is connected to the reference port as shown in figures 9.4 and 9.5. The purpose of this transducer is that it can be used as a calibration reference to quickly set zero for the other absolute pressure transducers in the system, or it can be used in a gauge pressure instrument to provide an absolute emulation mode of operation.

Barometric Calibration

This mode allows the active transducer (other than the Barometric Reference Transducer, itself) to be corrected to the same pressure reading as that of the Barometric Reference Transducer. Obviously, the Barometric Reference Transducer cannot be used to calibrate itself. The procedure to accomplish the barometric calibration is as follows:

1. Select the transducer to be calibrated as the active transducer. (See SETUP-SELECT ACTIVE TRANSDUCER).
2. Press [2nd] [CAL] to enter the CALIBRATION MODE (top line of the display).

3. Use [+] and [-] to scroll until the display shows:

```
CALIBRATION MODE
CALIBRATE WITH BAROMETRIC REFERENCE
```

then press [=].

4. Enter the zero password followed by [=].
5. When the password is accepted the display will prompt ENTER '='. Press [=] once more.
6. The display will show the barometric reference pressure on the top line, and the active sensor reading on the bottom line.
7. When both readings are stable except for the last digit, which may remain nervous, press [=] to execute the calibration. The barometric pressure will be copied to the active transducer.

The calibration of the selected transducer is immediate. The zero offset in memory is immediately displaced by the new, calculated zero, and the display returns to the calibration screen shown above. Press [CE] to return to the previous mode.

Transducer Selection

The primary transducer (address 0) is selected by default at power up. The *Local Operation* and *Remote Operation* sections of the manual show how to select either transducer as the active transducer through the SETUP menu in manual operation, or with the _PCS4 XDUCER command over a remote bus.

In addition to menu or bus selection, the EMUL key ([2nd] [0]) is configured to toggle between the primary and the alternate internal transducers.

When commanding a transducer change, if the current pressure is more than 10% (or 1 psi, whichever is greater) over the maximum or under the minimum range of the selected transducer the change will not be accepted, and the display will show the following message:

```
WARNING 01: UNABLE TO CHANGE TRANSDUCER
CURRENT READING OUT OF RANGE <USE CE>
```

Pneumatic Module

The pneumatic plumbing is arranged as shown on the pneumatic schematic in figure 9.6. This module includes a three-way solenoid valve (L6) installed such that the MEASURE/CONTROL port is routed to the primary transducer when the solenoid is relaxed, or to the alternate transducer when it is energized.

4 – BI-DIRECTIONAL PRESSURE CONTROL

A gauge pressure instrument can be ordered for plus and minus pressure control operation with respect to zero gauge pressure. The plus [+] and minus [-] keys on the keypad are used to enter a signed control point. When in CONTROL mode the normal increment/decrement functions of these two keys are disabled to accommodate bi-directional operation.

Local Operation

To enter a negative (vacuum) control point from the front panel first press the minus [-] key and then enter the control point. Entering a plus [+] before a positive control point is not required, but will be accepted. Control points in either direction must be within the range of the minimum and maximum control limits. All front panel displays of the measured or controlled pressure will include a preceding + or - polarity sign to preclude any ambiguity.

Remote Operation

For remote operation (GPIB or RS-232), to command a negative (vacuum) pressure the control point must be preceded by a minus (-) sign. The PCS 400M response will include a negative sign for negative pressures, and the resolution will be reduced by one decimal place. If the resolution can't be reduced to accommodate the minus sign the response will be "_____". It is not necessary to enter a plus (+) for positive control points, and there will not be a polarity indicator in the PCS 400M response string for positive pressures.

5 – PRESSURE EMULATION MODES

Mensor offers emulation mode options which allow gauge or absolute type transducers to simulate the other type transducer. With an emulation mode option installed the EMUL key is used in LOCAL mode to toggle between absolute and gauge modes. When a pressure value is displayed the suffix will change to 'A' (absolute) or 'G' (gauge), as appropriate, to indicate the current mode. The ID screen will display the full scale range and the native mode

of the primary transducer. Also, the native mode of all of the internal transducers is recorded on the front panel range label. In REMOTE mode the gauge/absolute toggle is made with the command "_PCS4 FUNC EMUL". With an emulation option Mensor can supply the user with calibration data for both the native and the emulated modes as an option.

The specifics of emulation mode functions, including how long it takes to complete a change, and the accuracy that can be attained while operating in the emulation mode, depends on several factors including:

- a. Does the PCS 400M include an internal Barometric Reference Transducer (BRT)?
- b. Are there any affected external (Bus) transducers?
- c. Are vacuum (negative) pressure readings a requirement?

NOTE: *The BRT is an absolute transducer and cannot be used to emulate gauge pressures.*

The three basic configurations for emulation modes are explained on the following page in paragraphs 5a, 5b and 5c. Some common requirements for all emulation modes are:

- a. All internal transducers (except the BRT in a gauge unit) must be of the same type.
- b. All external (Bus) transducers must have relief valves installed.
- c. All transducers with full scale ranges below 15 psig must have dual differential relief valves, and also must include a means to be isolated from the CONTROL/MEASURE port.

5a – Gauge Transducers (Absolute Emulation) without BRT

A PCS 400M equipped with from one to three internal gauge pressure transducers (no Barometric Reference Transducer) with the absolute pressure emulation option is configured as shown in the pneumatic schematic of figure 9.3 in the Appendix. A requirement for absolute emulation with this configuration is a vacuum source of at least 21 liters per minute capacity on the REFERENCE

port. Each transducer that will function in the emulation mode will require separate zero and span calibrations for each mode to achieve the greatest possible accuracy. To control pressures at or below atmospheric pressure a second vacuum pump is required on the EXHAUST port (see Option 4). Mensor supplies both gauge and absolute calibration data for each transducer with this option. These calibrations should be maintained separately throughout the life of the instrument.

5b – Gauge Transducers (Absolute and Vacuum Emulation) with BRT

This system configuration is shown in figure 9.4 in the *Appendix*. All internal transducers (except the Barometric Reference Transducer) must be gauge units. With the internal BRT the REFERENCE port vacuum pump is not required. Each transducer that will be used to control negative (vacuum) pressures must be bi-directional to –15 psig (see Option 4). The effect on a transducer when toggled between gauge and absolute modes depends on the transducer's native mode and which direction it is switching to as shown in table 8.1.

NOTE: *Techniques and equipment are currently not available for calibrating extremely low range absolute transducers. Instruments using such sensors may not achieve the rated accuracy when controlling absolute pressure near a perfect vacuum. Use only transducers above 7 psi in the absolute emulation mode for best results. Refer to the 'SETUP/Limits' function in the Local Operation section of the manual to see how to select specific transducers.*

5c – Absolute Transducers (Gauge Emulation) with BRT

Absolute transducers with the Barometric Reference Transducer configuration is shown in figure 9.5 in the *Appendix*. This pneumatic setup routes the BRT pressure port to the PCS 400M REFERENCE port. Table 8.2 shows what happens when each type of transducer is switched between its native and emulation mode.

Specifications

Uncertainty: When the active transducer output is combined with the BRT to derive an emulated pressure, the uncertainty of the emulated pressure will increase. The uncertainty should be determined with the methods described in the ISO document *ISO Guide to the Expression of Uncertainty in Measurement*.

Table 8.1– Transducer Type/Effect

Transducer Native Type	Effect when Gauge mode is switched to absolute	Effect when Absolute mode is switched to gauge
Gauge	<p>The current control point is increased by 14.696 psi.</p> <p>-----</p> <p>The control limits are increased by 14.696 psi.</p> <p>-----</p> <p>All subsequent pressure readings are the sum of the active transducer reading and the current barometric pressure.</p>	<p>The current control point is increased by 14.696 psi.</p> <p>-----</p> <p>The control limits are decreased by 14.696 psi.</p> <p>-----</p> <p>All subsequent pressure readings are those of the active transducer.</p>
Absolute	<p>The current control point is decreased by 14.696 psi.</p> <p>-----</p> <p>The control limits are decreased by 14.696 psi.</p> <p>-----</p> <p>All subsequent pressure readings are those of the active transducer.</p>	<p>The current control point is increased by 14.696 psi.</p> <p>-----</p> <p>The control limits are increased by 14.696 psi.</p> <p>-----</p> <p>All subsequent pressure readings are calculated by subtracting the current barometric pressure from the active transducer reading.</p>

Table 8.2 – Absolute Transducer Type/Effect

Transducer Native Type	Effect when Absolute mode is switched to gauge	Effect when Gauge mode is switched to absolute
Absolute	<p>The current control point is increased by 14.696 psi.</p> <p>-----</p> <p>The control limits are increased by 14.696 psi.</p> <p>-----</p> <p>All subsequent pressure readings are calculated by subtracting the current barometric pressure from the active transducer reading.</p>	<p>The current control point is decreased by 14.696 psi.</p> <p>-----</p> <p>The control limits are reduced by 14.696 psi.</p> <p>-----</p> <p>All subsequent pressure readings are those of the active transducer.</p>
Gauge	<p>The current control point is reduced by 14.696 psi.</p> <p>-----</p> <p>The control limits are decreased by 14.696 psi.</p> <p>-----</p> <p>All subsequent pressure readings are those of the active transducer.</p>	<p>The current control point is increased by 14.696 psi.</p> <p>-----</p> <p>The control limits are increased by 14.696 psi.</p> <p>-----</p> <p>All subsequent pressure readings are the sum of the current barometric pressure and the active transducer reading.</p>

6 – LOW PRESSURE EXTERNAL PLUMBING

This option applies to a PCS 400M with a full scale range of 3 psig or lower. These low ranges require the installation of special hardware on the pneumatic ports as illustrated in figures 8.5 and 8.6. This additional hardware is supplied by Mensor and is shipped with the instrument.

The item shown attached to the REFERENCE port is a pressure snubber made up of a capped T-fitting with an installed filter. Its purpose is to dampen out the ambient pressure changes caused by such things as doors being opened or closed, or the cycling of blowers on heating/air conditioning systems. These minor pressure variations are significant when trying to accurately measure and control very low pressures.

If a device under test includes a reference port, connect that port to the capped end of the filter fitting on the PCS 400M REFERENCE port.

A Conoflow™ pressure regulator is shown attached to the SUPPLY port. Apply 20 to 30 psig source pressure to the end of this device that has “IN” molded into the casting. The opposite end connects directly to the PCS 400M’s SUPPLY port.

Connect a vacuum pump to the EXHAUST port, and connect the device under test (DUT) to the MEASURE/CONTROL port.

With the test setup connected in the above manner very low pressure testing can proceed with a minimum of interference from outside influences. For additional assistance with specific questions or problems contact Mensor.

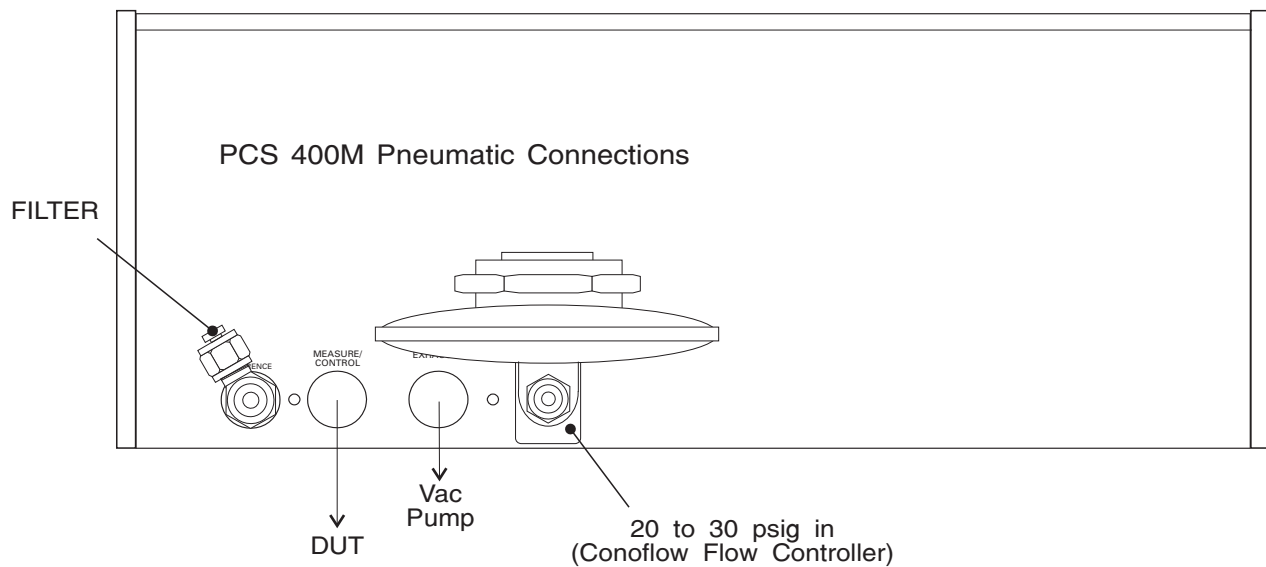

Figure 8.5 - Pneumatic Connections for Low Pressure

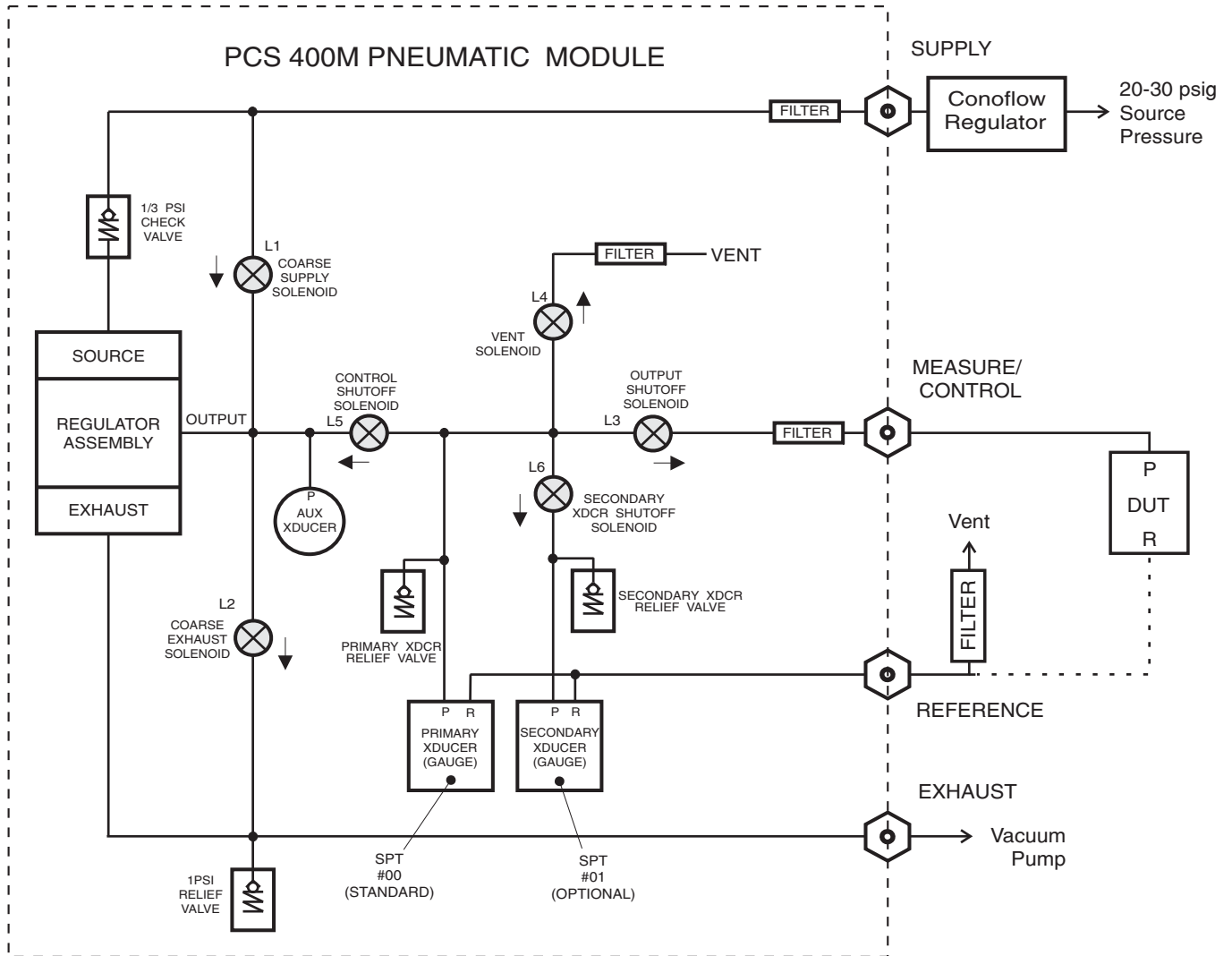

Figure 8.6 - Pneumatic Module for Low Pressure

APPENDIX

MEASUREMENT UNITS

The unitno command selects the measurement units to be output on the bus and the display.

Table 9.1 – Measurement Units (unitno)

Unit No.	Description	Output Format
1	pounds per square inch	PSI
2	inches of mercury @ 0°C	INHG @ 0C
3	inches of mercury @ 60°F	INHG @ 60F
4	inches of water @ 4°C	INH2O @ 4C
5	inches of water @ 20°C	INH2O @ 20C
6	inches of water @ 60°F	INH2O @ 60F
7	feet of water @ 4°C	FTH2O @ 4C
8	feet of water @ 20°C	FTH2O @ 20C
9	feet of water @ 60°F	FTH2O @ 60F
10	millitorr	MTORR
11	inches of seawater @ 0°C 3.5% salinity	INSW
12	feet of seawater @ 0°C 3.5% salinity	FTSW
13	atmospheres	ATM
14	bars	BAR
15	millibars	MBAR
16	millimeters of water @ 4°C	MMH2O @ 4C
17	centimeters of water @ 4°C	CMH2O @ 4C
18	meters of water @ 4°C	MH2O @ 4C
19	millimeters of mercury @ 0°C	MMHG @ 0C
20	centimeters of mercury @ 0°C	CMHG @ 0C
21	torr	TORR
22	kilopascals	KPA
23	pascals	PA
24	dyne per square centimeter	DYNE/SQ CM
25	grams per square centimeter	G/SQ CM
26	kilograms per square centimeter	KG/SQ CM
27	meters of seawater @ 0°C 3.5% sal	MSW
28	ounce per square inch	OSI
29	pounds per square foot	PSF
30	tons per square foot	TSF
31	percent of full scale	%FS
32	micron HG @ 0°C	MICRON HG @ 0C
33	ton per square inch	TSI
34	n/a	n/a
35	hectopascals	HPA
36	megapascals	MPA
37	millimeters of water @ 20°C	mmH2O @ 20C
38	centimeters of water @ 20°C	cmH2O @ 20C
39	meters of water @ 20°C	mH2O @ 20C

CONVERSION FACTORS, PSI

The values listed in the column **To convert from PSI** are the values imbedded in the instrument program. The values listed under **To convert to PSI** are internally calculated approximations based on the imbedded values.

Table 9.2 – Conversion Factors, PSI

Unit No.	Pressure Unit	To Convert from PSI	To Convert to PSI
1	PSI	1	1
2	INHG @ 0C	2.036020	0.4911544
3	INHG @ 60F	2.041772	0.4897707
4	INH2O @ 4C	27.68067	3.612629E-02
5	INH2O @ 20C	27.72977	3.606233E-02
6	INH2O @ 60F	27.70759	0.03609119
7	FTH2O @ 4C	2.306726	0.4335149
8	FTH2O @ 20C	2.310814	0.4327480
9	FTH2O @ 60F	2.308966	0.4330943
10	MTORR	51715.08	1.933672E-05
11	INSW@ 0C 3.5% sal	26.92334	3.714250E-02
12	FTSW@ 0C 3.5% sal	2.243611	0.445710
13	ATM	6.804596E-02	14.69595
14	BAR	6.894757E-02	1.450377E+01
15	MBAR	68.94757	1.450377E-02
16	MMH2O @ 4C	703.0890	1.422295E-03
17	CMH2O @ 4C	70.30890	1.422295E-02
18	MH2O @ 4C	0.7030890	1.422295
19	MMHG @ 0C	51.71508	1.933672E-02
20	CMHG @ 0C	5.171508	1.933672E-01
21	TORR	51.71508	1.933672E-02
22	KPA	6.894757	1.450377E-01
23	PA	6894.757	1.450377E-04
24	DYNE/SQ CM	68947.57	1.450377E-05
25	G/SQ CM	70.30697	1.422334E-02
26	KG/SQ CM	0.07030697	1.422334E+01
27	MSW @ 0C 3.5% sal	0.6838528	1.462303
28	OSI	16	0.0625
29	PSF	144	6.94444E-03
30	TSF	0.072	13.88889
31	% FS	(PSI / RANGE) x 100	(% FS x RANGE) / 100
32	MICRON HG @ 0C	51715.08	1.933672E-05
33	TSI	0.0005	2000
35	HPA	68.94757	1.450377E-02
36	MPA	6.894757E-03	1.450377E+02
37	MMH2O @ 20C	704.336	0.001419777
38	CMH2O @ 20C	70.4336	0.01419777
39	MH2O @ 20C	0.704336	1.419777

CONVERSION FACTORS, PASCAL

The following table lists factors which should be used as multipliers when converting other pressure units to or from Pascal.

Table 9.3 – Conversion Factors, Pascal

Unit No.	Pressure Unit	To Convert from Pascal	To Convert to Pascal
1	PSI	1.450377E-04	6.894757E+03
2	INHG @ 0C	2.952997E-04	3.386390E+03
3	INHG @ 60F	2.961339E-04	3.376850E+03
4	INH2O @ 4C	4.014741E-03	2.490820E+02
5	INH2O @ 20C	4.021862E-03	2.486410E+02
6	INH2O @ 60F	4.018645E-03	2.488400E+02
7	FTH2O @ 4C	3.345622E-04	2.988980E+03
8	FTH2O @ 20C	3.351551E-04	2.983692E+03
9	FTH2O @ 60F	3.348871E-04	2.986080E+03
10	MTORR	7.500636E+00	1.333220E-01
11	INSW@ 0C 3.5% sal	3.904899E-03	2.560885E+02
12	FTSW@ 0C 3.5% sal	3.254082E-04	3.073062E+03
13	ATM	9.869230E-06	1.013250E+05
14	BAR	1.00000E-05	1.00000E+05
15	MBAR	1.00000E-02	1.00000E+02
16	MMH2O @ 4C	1.019744E-01	9.806378E+00
17	CMH2O @ 4C	1.019744E-02	9.806378E+01
18	MH2O @ 4C	1.019744E-04	9.806378E+03
19	MMHG @ 0C	7.500636E-03	1.333220E+02
20	CMHG @ 0C	7.500636E-04	1.333220E+03
21	TORR	7.500636E-03	1.333220E+02
22	KPA	1.00000E-03	1.00000E+03
23	PA	1.00000E+00	1.00000E+00
24	DYNE/SQ CM	1.00000E+01	1.00000E-01
25	G/SQ CM	1.019716E-02	9.806647E+01
26	KG/SQ CM	1.019716E-05	9.806647E+04
27	MSW @ 0C 3.5% sal	9.918444E-05	1.008222E+04
28	OSI	2.320603E-03	4.309223E+02
29	PSF	2.088543E-02	4.788025E+01
30	TSF	1.044271E-05	9.576052E+04
32	MICRON HG @ 0C	7.500636E+00	1.333220E-01
33	TSI	7.251885E-08	1.378951E+07
35	HPA	1.00000E-02	1.00000E+02
36	MPA	1.00000E-06	1.00000E+06
37	MMH2O @ 20C	1.021553E-01	9.789017E+00
38	CMH2O @ 20C	1.021553E-02	9.789017E+01
39	MH2O @ 20C	1.021553E-04	9.789017E+03

TEMPERATURE CONVERSION

Find the known value in a center (shaded) column. If the known value is in °C, then the equivalent value is found in the °F column. If the known value is in °F, then the conversion is found in the °C column.

Table 9.4 – Temperature Conversion Chart

°C		°F	°C		°F	°C		°F	°C		°F
-17.78	0	32.00	10.00	50	122.00	37.78	100	212.00	65.56	150	302.00
-17.22	1	33.80	10.56	51	123.80	38.33	101	213.80	66.11	151	303.80
-16.67	2	35.60	11.11	52	125.60	38.89	102	215.60	66.67	152	305.60
-16.11	3	37.40	11.67	53	127.40	39.44	103	217.40	67.22	153	307.40
-15.56	4	39.20	12.22	54	129.20	40.00	104	219.20	67.78	154	309.20
-15.00	5	41.00	12.78	55	131.00	40.56	105	221.00	68.33	155	311.00
-14.44	6	42.80	13.33	56	132.80	41.11	106	222.80	68.89	156	312.80
-13.89	7	44.60	13.89	57	134.60	41.67	107	224.60	69.44	157	314.60
-13.33	8	46.40	14.44	58	136.40	42.22	108	226.40	70.00	158	316.40
-12.78	9	48.20	15.00	59	138.20	42.78	109	228.20	70.56	159	318.20
-12.22	10	50.00	15.56	60	140.00	43.33	110	230.00	71.11	160	320.00
-11.67	11	51.80	16.11	61	141.80	43.89	111	231.80	71.67	161	321.80
-11.11	12	53.60	16.67	62	143.60	44.44	112	233.60	72.22	162	323.60
-10.56	13	55.40	17.22	63	145.40	45.00	113	235.40	72.78	163	325.40
-10.00	14	57.20	17.78	64	147.20	45.56	114	237.20	73.33	164	327.20
-9.44	15	59.00	18.33	65	149.00	46.11	115	239.00	73.89	165	329.00
-8.89	16	60.80	18.89	66	150.80	46.67	116	240.80	74.44	166	330.80
-8.33	17	62.60	19.44	67	152.60	47.22	117	242.60	75.00	167	332.60
-7.78	18	64.40	20.00	68	154.40	47.78	118	244.40	75.56	168	334.40
-7.22	19	66.20	20.56	69	156.20	48.33	119	246.20	76.11	169	336.20
-6.67	20	68.00	21.11	70	158.00	48.89	120	248.00	76.67	170	338.00
-6.11	21	69.80	21.67	71	159.80	49.44	121	249.80	77.22	171	339.80
-5.56	22	71.60	22.22	72	161.60	50.00	122	251.60	77.78	172	341.60
-5.00	23	73.40	22.78	73	163.40	50.56	123	253.40	78.33	173	343.40
-4.44	24	75.20	23.33	74	165.20	51.11	124	255.20	78.89	174	345.20
-3.89	25	77.00	23.89	75	167.00	51.67	125	257.00	79.44	175	347.00
-3.33	26	78.80	24.44	76	168.80	52.22	126	258.80	80.00	176	348.80
-2.78	27	80.60	25.00	77	170.60	52.78	127	260.60	80.56	177	350.60
-2.22	28	82.40	25.56	78	172.40	53.33	128	262.40	81.11	178	352.40
-1.67	29	84.20	26.11	79	174.20	53.89	129	264.20	81.67	179	354.20
-1.11	30	86.00	26.67	80	176.00	54.44	130	266.00	82.22	180	356.00
-0.56	31	87.80	27.22	81	177.80	55.00	131	267.80	82.78	181	357.80
0.00	32	89.60	27.78	82	179.60	55.56	132	269.60	83.33	182	359.60
0.56	33	91.40	28.33	83	181.40	56.11	133	271.40	83.89	183	361.40
1.11	34	93.20	28.89	84	183.20	56.67	134	273.20	84.44	184	363.20
1.67	35	95.00	29.44	85	185.00	57.22	135	275.00	85.00	185	365.00
2.22	36	96.80	30.00	86	186.80	57.78	136	276.80	85.56	186	366.80
2.78	37	98.60	30.56	87	188.60	58.33	137	278.60	86.11	187	368.60
3.33	38	100.40	31.11	88	190.40	58.89	138	280.40	86.67	188	370.40
3.89	39	102.20	31.67	89	192.20	59.44	139	282.20	87.22	189	372.20
4.44	40	104.00	32.22	90	194.00	60.00	140	284.00	87.78	190	374.00
5.00	41	105.80	32.78	91	195.80	60.56	141	285.80	88.33	191	375.80
5.56	42	107.60	33.33	92	197.60	61.11	142	287.60	88.89	192	377.60
6.11	43	109.40	33.89	93	199.40	61.67	143	289.40	89.44	193	379.40
6.67	44	111.20	34.44	94	201.20	62.22	144	291.20	90.00	194	381.20
7.22	45	113.00	35.00	95	203.00	62.78	145	293.00	90.56	195	383.00
7.78	46	114.80	35.56	96	204.80	63.33	146	294.80	91.11	196	384.80
8.33	47	116.60	36.11	97	206.60	63.89	147	296.60	91.67	197	386.60
8.89	48	118.40	36.67	98	208.40	64.44	148	298.40	92.22	198	388.40
9.44	49	120.20	37.22	99	210.20	65.00	149	300.20	92.78	199	390.20

SOLENOID VALVE TRUTH TABLE

Table 9.5 – Solenoid Valve Truth Table

Valve Mode	L1 Coarse Supply	L2 Coarse Exhaust	L3 Output Shutoff	L4 Vent	L5 Control Shutoff	*L6 2nd Xdcr Shutoff
POWER OFF	–	–	–	–	–	–
STANDBY	–	1	–	–	–	–
MEASURE	–	1	ON	–	–	3
PRE-CONT	–	–	–	–	ON	3
CONTROL	2	2	ON	–	ON	3
VENT	–	–	ON	ON	ON	3
INTERNAL LEAK CHK	–	–	–	–	ON	3
EXTERNAL LEAK CHK	–	–	ON	–	ON	3

NOTE: All valves are normally closed (NC).

* = L6 included only on multiple range units. (See schematics near the end of this Appendix section)

– = OFF

1 = ON for versions 2.00 to 2.11. OFF for all other versions.

2 = ON or OFF depending on commanded pressure.

3 = ON if system pressure is less than or equal to address 01 transducer range; OFF otherwise.

HEAD PRESSURE CORRECTION

The accuracy of pressure measurement depends on several factors, one of which is the consideration of the head pressure in the system. The pressure medium, whether a gas or liquid, can cause an error in the measurement if not considered. In some cases the offset may be insignificant, and it may be ignored. The following information provides instructions for determining the density of the pressure medium and how to calculate the head pressure effect.

Gas Density

Liquids and gases have mass and are affected by gravity. The extent of the effect is dependent upon the density of the pressure medium. Liquids normally have a constant density that does not change with pressure. Gases, however, increase in density as the pressure increases. To determine the density of a gas at a specific pressure multiply the absolute pressure by the density per standard atmosphere from the following table. For gas the head pressure difference due to temperature changes within the compensated temperature range will be insignificant.

Table 9.6 – Gas Density

Gas @ 23°C and 1 Standard Atmosphere	Density/Standard Atmosphere ratio in lbs/in ³ (D _{psi})
Air, Dry	2.9314 X 10 ⁻⁶
Argon (A)	4.0443 X 10 ⁻⁶
Carbon Dioxide (CO ₂)	4.4823 X 10 ⁻⁶
Helium (He)	4.0461 X 10 ⁻⁷
Hydrogen (H ₂)	2.0379 X 10 ⁻⁷
Nitrogen (N ₂)	2.8355 X 10 ⁻⁶

Liquid Density

In the table below, the density of water at various temperatures is given. The density of a liquid is commonly specified in grams per milliliter (*g/ml*). To convert to *lbs/cu.in.* multiply the density by 0.036127292.

Table 9.7 – Liquid Density

Liquid	Density Pounds/in ³ (D)
Pure Water @ 15°C	0.0360947
Pure Water @ 20°C	0.0360623
Pure Water @ 25°C	0.0360205
Pure Water @ 30°C	0.0359700
Pure Water @ 35°C	0.0359116

Head Pressure Calculation

The pressure at the input port (P_2 in figure 9.1) of the Device Under Test (DUT) will be a positive number if the standard is positioned higher than the DUT. If the standard is lower than the DUT the head pressure correction will be a negative value. The equation used to calculate the head pressure for a gas medium is:

$$P_2 = P_1 (1 + h \times D_{\text{psi}})$$

h = Difference in vertical height between the center lines of the two pressure ports.

D_{psi} = Gas density (refer to the "Gas Density" table).

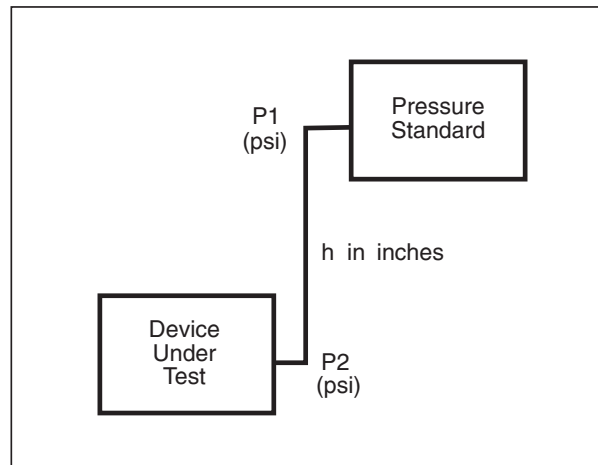

Figure 9.1 - Head Pressure Calculation

To calculate head pressure for a liquid medium the equation is:

$$P_2 = P_1 + h \times D$$

SAMPLE PROGRAM

```

*****
' GENERAL PROGRAM DESCRIPTION

' This is a sample program in Microsoft QuickBasic which demonstrates
' some of the functions of the PCS 400M IEEE commands. The PCS 400M should
' be set to address 3. This program uses the National Instruments GPIB drivers
*****

CLS

    ' INITIALIZE EQUIPMENT
    ' ASSUMES PCS 400 IS SET TO ADDRESS 3

CALL IBFIND("DEV3", BRD3%)

    ' THIS PART OF THE PROGRAM READS
    ' THE SERIAL NUMBER OF THE PCS400
    ' AND PRINTS IT TO THE SCREEN.

CALL IBWRT(BRD3%, "_PCS4 ID?" + CHR$(10))
RD$ = SPACE$(33)
CALL IBRD(BRD3%, RD$)
ID$ = MID$(RD$, 2, 27)
PRINT " "
PRINT " "
PRINT " "
PRINT "BELOW IS THE MENSOR MODEL, SERIAL # AND SOFTWARE VERSION"
PRINT " "
PRINT ID$

    ' THIS SECTION WILL ALLOW THE USER TO
    ' ENTER A CONTROL PRESSURE

    ' CHANGES THE UNITS TO PSI

CALL IBWRT(BRD3%, "_PCS4 UNIT 01" + CHR$(10))

    ' THIS COMMAND VENTS THE PCS400

CALL IBWRT(BRD3%, "_PCS4 FUNC VENT" + CHR$(10))

    ' PROMPTS USER FOR CONTROL PRESSURE

PRINT "ENTER THE DESIRED CONTROL PRESSURE"
PRINT "CAUTION! DO NOT EXCEED THE FULL SCALE OF THE INSTRUMENT "
PRINT " "
INPUT "ENTER PRESSURE THEN PRESS RETURN ", CONTROL!
CONTROL$ = STR$(CONTROL!)

    ' THIS COMMAND SENDS THE PCS400 INTO
    ' CONTROL AT A PRESSURE POINT
    ' (WHICH IS THE VARIABLE CONTROL$)
    ' ENTERED IN BY THE USER.

CALL IBWRT(BRD3%, "_PCS4 FUNC CTRL" + CONTROL$ + CHR$(10))

```



```

    ' ONE COULD HAVE ALSO SET THE CONTROL MODE TO A SPECIFIED
    ' VALUE BY DOING THE FOLLOWING:
    ' CALL IBWRT (BRD3%,"_PCS4 FUNC CTRL 1.00" + CHR$(10))
    ' THIS TELLS THE PCS400 TO CONTROL AT 1.00 PSI

    ' THIS SECTION WAITS FOR THE STABLE
    ' SIGN BEFORE CONTINUING

DO

    CALL IBWRT(BRD3%, "_PCS4 STAT?" + CHR$(10))
    RD$ = SPACE$(33)
    CALL IBRD(BRD3%, RD$)
    LOOP UNTIL MID$(RD$, 7, 1) = "S"

    ' READS PCS400 AND PRINTS THE MEASURED
    ' CONTROL PRESSURE TO THE SCREEN

    RD$ = SPACE$(99): CALL IBRD(BRD3%, RD$)
    PCS! = VAL(MID$(RD$, 2, 8))

    ' DELAYS PRINTING MEASURED CONTROL
    ' PRESSURE FOR 10 SECONDS

    TIME! = TIMER: DO: LOOP UNTIL TIMER > TIME! + 10
    PRINT "THE MEASURED CONTROL PRESSURE IS "; PCS!; " PSI "

    ' DELAYS VENTING THE PCS400 FOR 1 SECOND
    TIME! = TIMER: DO: LOOP UNTIL TIMER > TIME! + 1

    ' VENTS THE PCS400.

    CALL IBWRT(BRD3%, "_PCS4 FUNC VENT" + CHR$(10))

    ' THIS COMMAND TAKES THE PCS400 OUT OF REMOTE.

    CALL IBLOC(BRD3%)
    PRINT " "
    PRINT "END OF PROGRAM"

    ' END OF PROGRAM
```

COMMON REMOTE COMMANDS

All the commands begin with “_PCS4” and end with the selected termination character:

Table 9.8 - Quick Reference List of Common Remote Commands

<p>Commands: AUTORANGE 0 AUTORANGE 1 CAL ATM CAL DISABLE OFF CAL DISABLE ON CAL SPAN value - true span CAL ZERO value - true zero CTRL value CTRLMAX value - max ctrl press CTRLMIN value - min ctrl press DEFAULT FILTERSETTING digits - 00 to 99 filter % FILTERWINDOW value - max window FUNC CTRL <value<unitno>> FUNC EMUL FUNC MEAS <unitno> FUNC STBY <unitno> FUNC VENT <unitno> OUTFORM digit - 1 'sp value crlf' 2 'sp value, unitno, function crlf' 3 'sp value, ratevalue crlf' 4 'sp value, minpeak, maxpeak crlf' 5 'sp value, auxvalue crlf' 6 'sp value, value, stable crlf' 7 'sp value, no barometer crlf' or 'sp value, value crlf' PEAKRESET PEAKUNIT digit - 0 normal 1 max press 2 min press RATE value - ctrl rate RATEUNIT digit - 0 normal 1 units/min 2 units/sec STABLEDELAY digits - no. of readings for stable STABLEWINDOW value - pressure window for stable UNIT unitno XDUCER digits</p>	<p>Queries: AUTORANGE? CTRL? - 'sp value crlf' CTRLMAX? - 'sp value crlf' CTRLMIN? - 'sp value crlf' EMUL? - '0 crlf' or '1 crlf' ERR? - 'Ennnn error string crlf' EXHAUSTP? - 'sp value, units crlf' FILTERSETTING? - 'sp percent crlf' FILTERWINDOW? - 'sp window crlf' ID? - 'MENSOR, PCS-400, snsnsn, x.xx crlf' LIST? - 'sp 0,1,2 crlf' or 'sp 0,2 crlf' OUTFORM? - 'sp digits crlf' PEAKUNIT? - 'sp digit, name crlf' RANGEMAX? - 'sp value crlf' RANGEMIN? - 'sp value crlf' RATE? - 'sp value crlf' RATEUNIT? - 'sp digit, name crlf' READING? - 'sp value crlf' SOURCEP? - 'sp value, units crlf' SPAN? - 'sp value crlf' STABLEDELAY? - 'sp no_of_readings crlf' STABLEWINDOW? - 'sp value crlf' STAT? - 'mode, stable crlf' UNIT? - 'sp digits, unitname, abs_or_diff crlf' XDUCER? - 'sp digits crlf' XDUCERID? - 'sp Mensor, PBT, xducer, sn, min, max crlf' ZERO? - 'sp value crlf'</p>
	<p>Tests: TEST EXHAUSTP? - 'T value units crlf' TEST REG? - 'T stat value,stat value,stat value, stat value crlf' value = press change TEST SOURCEP? - 'T value units crlf' TEST XDUCER? <digits> - xducer number - 'T stat, pcounts, tcounts crlf'</p>

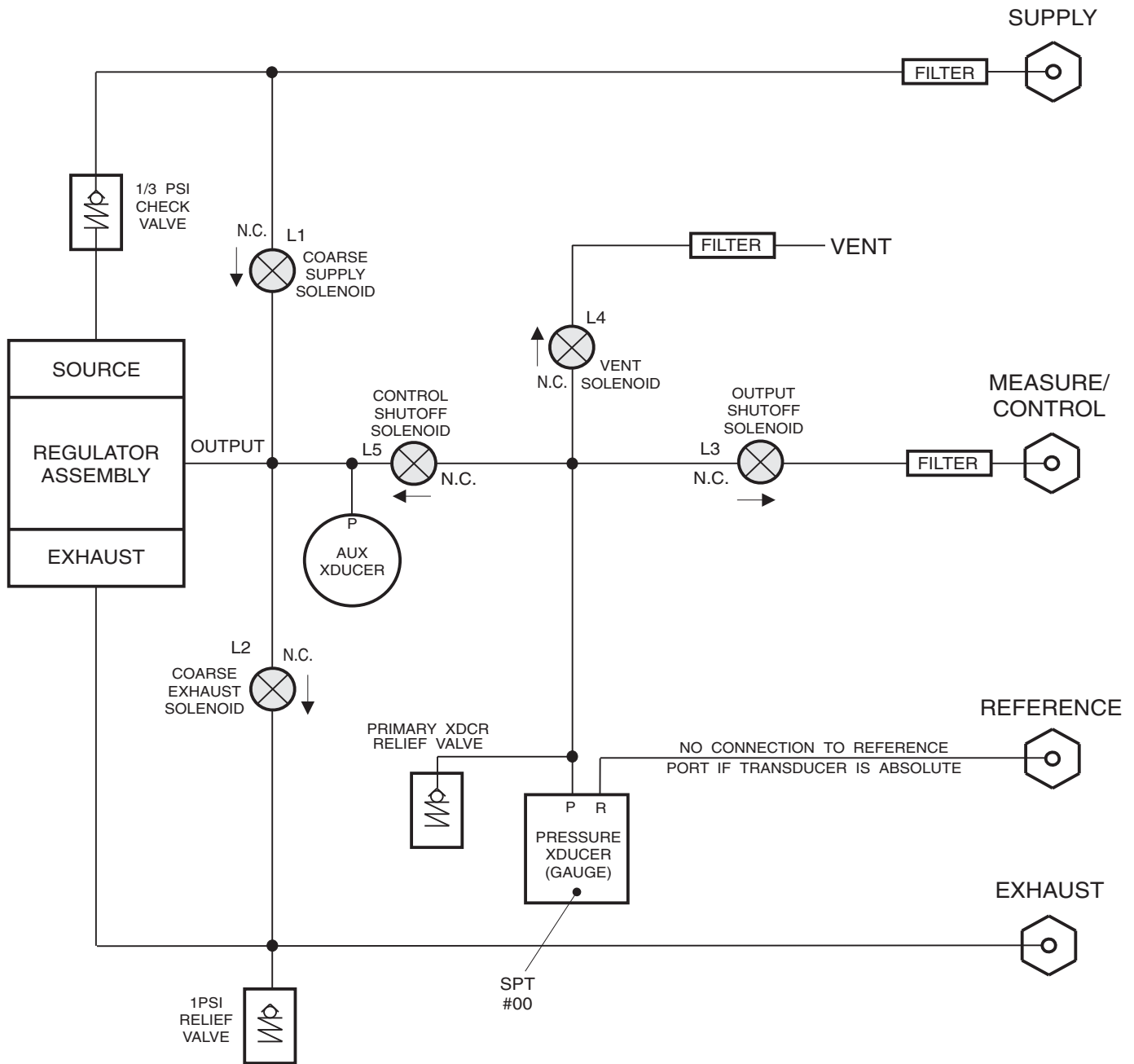

- NOTES: 1. ALL SOLENOID VALVES ARE 2-WAY, NORMALLY CLOSED (N.C.).
 2. PNEUMATICS SHOWN WITH GAUGE PRESSURE TRANSDUCER.
 3. MULTI-RANGE (OPTIONAL) SCHEMATICS ARE INCLUDED IN THE APPENDIX.

Figure 9.2 - Pneumatic Schematic - Standard PCS 400M

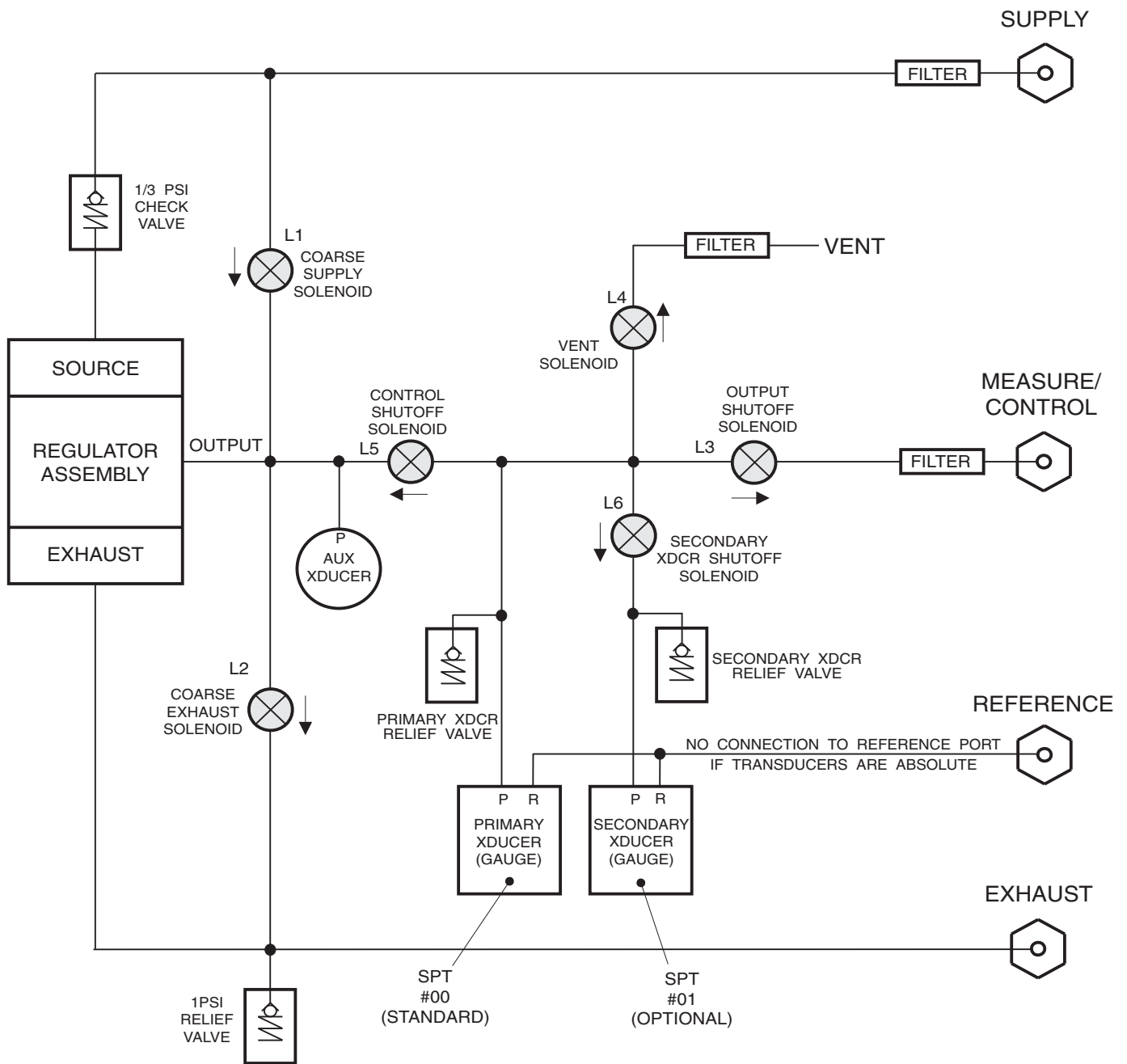

NOTE: ALL SOLENOID VALVES ARE 2-WAY NORMALLY CLOSED (N.C.).

Figure 9.3 - Pneumatic Schematic
Dual Range PCS 400M

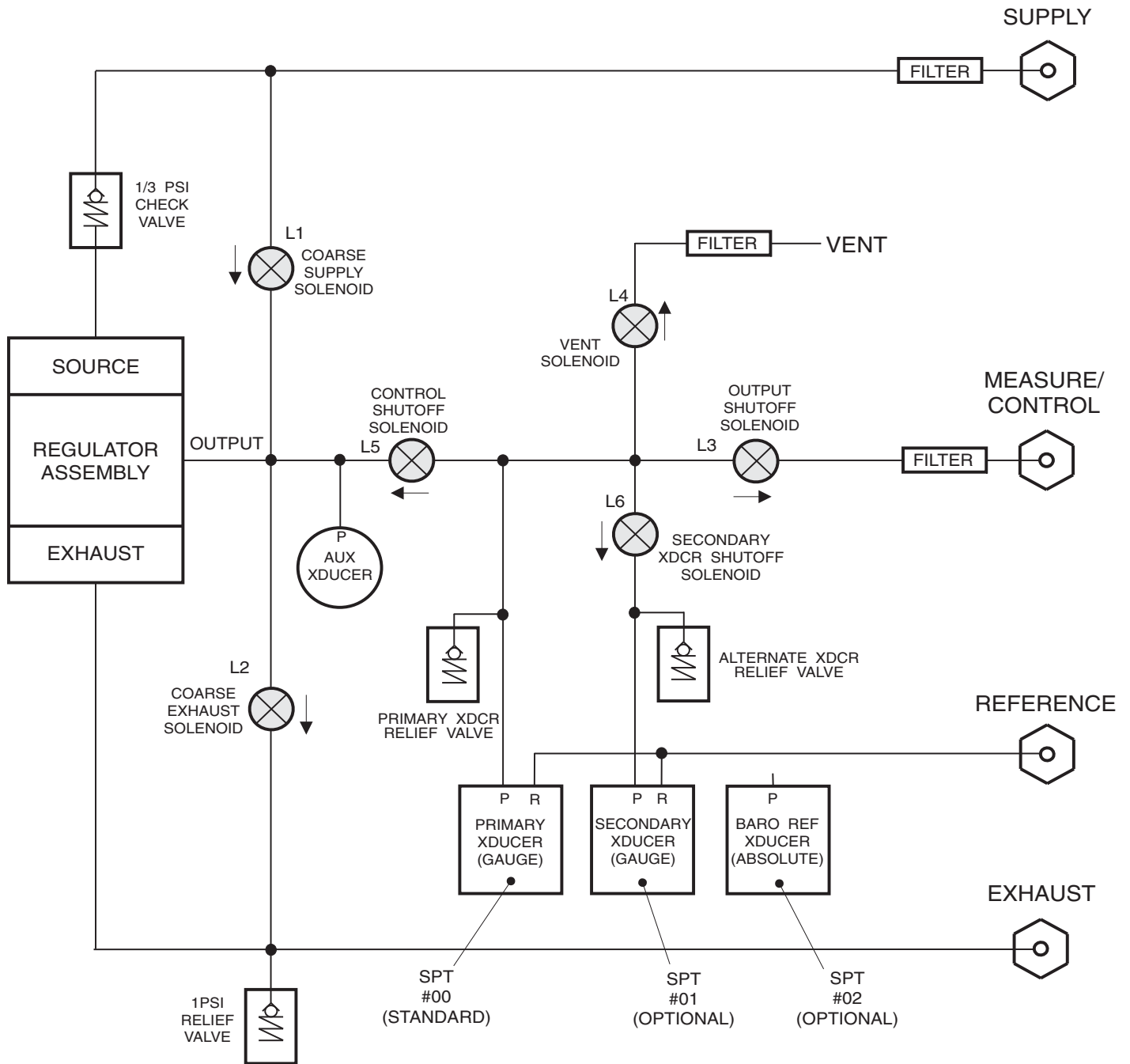

NOTE: ALL SOLENOID VALVES ARE 2-WAY NORMALLY CLOSED (N.C.).

Figure 9.4 - Pneumatic Schematic
Dual Gauge Pressure with Barometric Reference Transducer

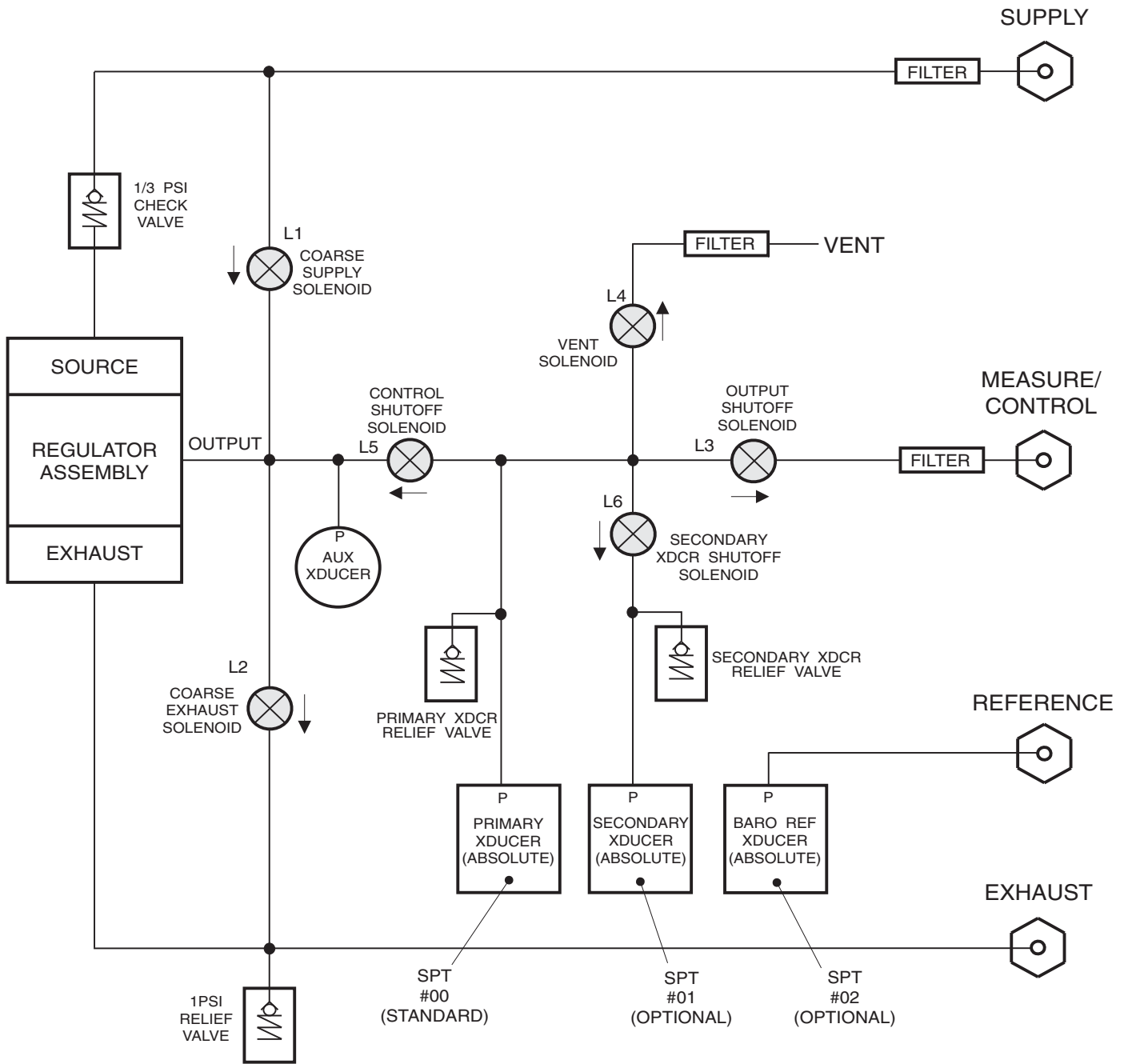

NOTE: ALL SOLENOID VALVES ARE 2-WAY NORMALLY CLOSED (N.C.).

Figure 9.5 - Pneumatic Schematic
Dual Absolute Pressure with Barometric Reference Transducer

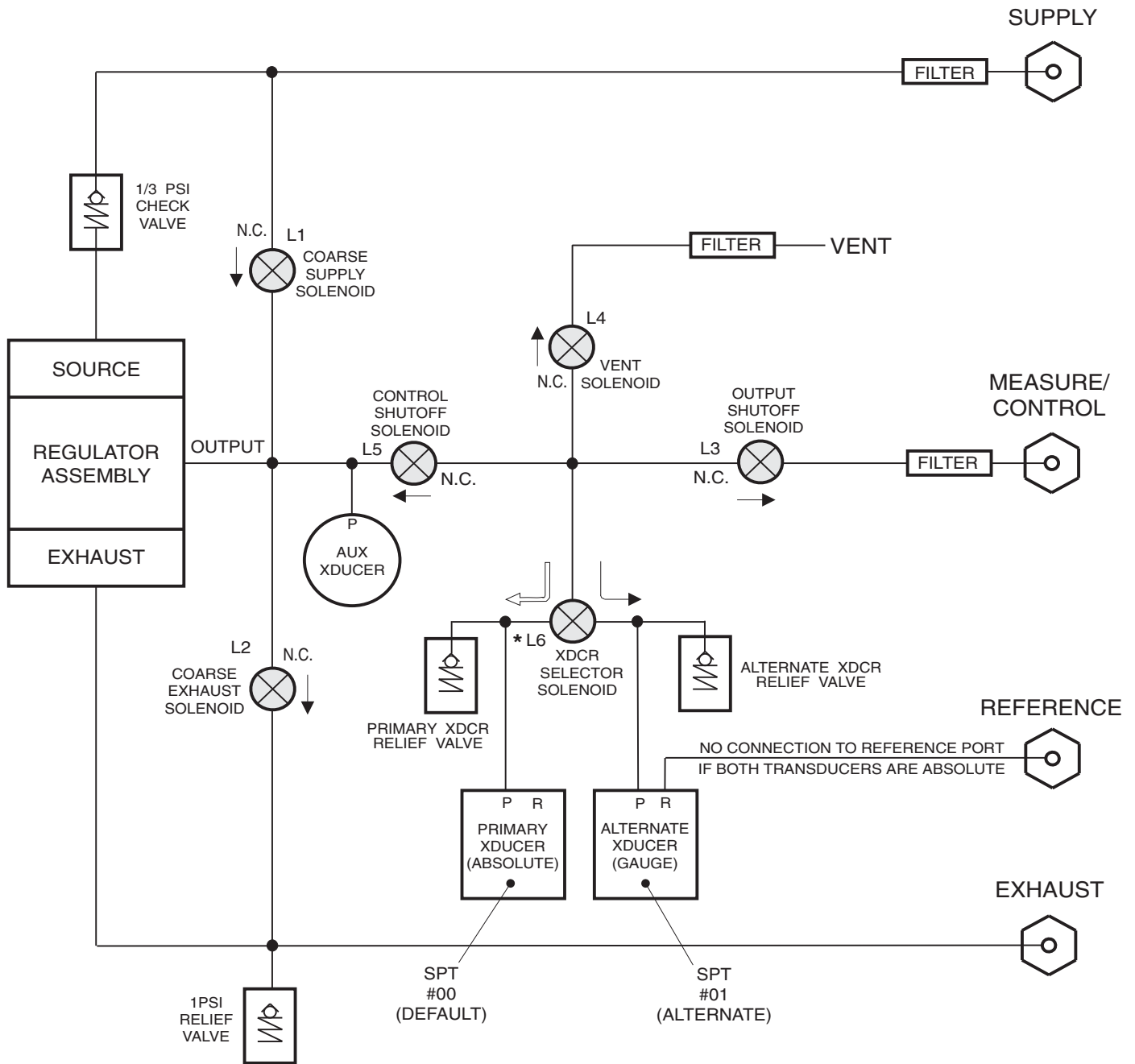

NOTES: L1 THROUGH L5 ARE 2-WAY, NORMALLY CLOSED (N.C.).

* L6 IS A 3-WAY SOLENOID VALVE. THE ARROWS SHOW PRESSURE FLOW THROUGH THE VALVE.



Figure 9.6 - Pneumatic Schematic
Two Independent Transducers



PCS 400 SEQUENCE PROGRAM SCRIPT

Sh ___ of ___ Sequence # ___

Title: _____ By: _____
 Purpose: _____ Date: _____

STEP No.	*MODE S-M-C-V-L	SETPOINT (Cont only)	HOLD (Sec)	LOOP TO	COMMENTS
1				X	
2					
3					
4					
5					
6					
7					
8					
9					
10					
11					
12					
13					
14					
15					
16					
17					
18					
19					
20					
21					
22					
23					
24					
25					
26					
27					
28					
29					
30					
31					
32					
33					
34					
35					
36					
37					
38					
39					
40					
41					
42					
43					
44					
45					
46					
47					
48					
49					
50					

MC 403D

* S-M-C-V or L is Standby, Measure, Control, Vent or Loop. Loop can be last step only; not allowed for step 1.

INDEX

A

- Absolute Calibration Setup 6-3
- Absolute Pressure Emulation 8-6 - 8-7
- Accreditations 1-6
- Accuracy 6-1, 7-1
- Adapters, Fitting 1-1, 2-1, 7-2
- Appendix 9-1 - 9-16
 - Common Remote Commands 9-10
 - Conversion Factors, Pascal 9-3
 - Conversion Factors, PSI 9-2
 - Head Pressure Correction 9-6
 - Measurement Units 9-1
 - Pneumatic Schematics 9-11 - 9-15
 - Sample Program 9-8
 - Sequence Program Script 9-16
 - Solenoid Valve Truth Table 9-5
 - Temperature Conversion Table 9-4
- Autorange Feature 3-7 - 3-8

B

- Barometric Calibration 3-3, 8-5
- Baro Ref Transducer 2-1, 8-5 - 8-7, 9-13 - 9-14
- Battery 5-2
- Bi-Directional Pressure Control 8-6

C

- Cable Requirements, RS-232 4-15
- Calibration 1-5, 1-6, 6-1 - 6-4
 - Absolute Pressure Instrument 6-3
 - Adjustments, Zero and Span 7-1
 - Barometric 8-5
 - Environment 6-1
 - Gauge Pressure Instrument 6-2
 - Interval 7-1
 - Medium 6-1
 - Pressure Standard 6-1
 - Procedures 6-1
 - Services 1-6
 - Stability 7-1
- Case, Transport 8-4
- Caution/Warning iii, 2-1, 2-2, 3-9, 5-1 - 5-4, 6-2, 6-3, 8-2
- Changing the Mode of Operations 4-11 - 4-12
 - Change Units 4-12
 - Changing Output Format 4-12
 - Control 4-11
 - Measure 4-11
 - Re-Initialize 4-13
 - Return and Clear Error 4-14
 - Return Control Limits 4-14
 - Return Standard Reading 4-12
 - Return Unit ID 4-13
 - Standby 4-12
 - Vent 4-12
- Chassis Assembly 1-4, 5-2
- Command Set, PCS 200 4-9
- Command Set, PCS 400M 4-2

- Commands 4-3 - 4-4
- Definitions 4-2
- Error Codes 4-7 - 4-8
- Queries 4-4 - 4-5
- Responses 4-6
- Tests 4-4
- Commands, Quick Reference (Remote) 9-10
- Connections, Pressure 2-1
 - Exhaust Pressure Port 2-1
 - Measure/Control Pressure Port 2-1
 - Reference Pressure Port 2-1
 - Supply Pressure Port 2-1
- Consumption, Supply 7-2
- Control Modes 3-8
 - Incrementing the Control Point 3-9
 - Input a Control Point Value 3-9
 - Multiple Transducers 3-8
 - NORMAL Mode 3-8
 - RATE Mode 3-8
 - Regulator Response 3-9
 - Setup for Control Mode 3-9
- Control Pressure 2-2, 7-1
- Control Stability 7-1
- Control Time 7-2
- Conversion Chart, Temperature 9-4
- Conversion Factors, Pascal 9-3
- Conversion Factors, Psi 9-2
- Cord, Power 1-1, 7-2
- CPU Board 1-2, 5-2

D

- Damage, Shipping 1-1
- Data Bits Format 4-15
- Default Values 3-6
- Definitions, PCS 400 Command Set 4-2
- Density, Gas 9-6
- Density, Liquid 9-6
- Device Address 4-1
- Device Dependent Messages 4-1
- Did you get Everything? 1-1
- Dimensional Outline 7-3
- Disk Drive 1-2, 5-1
- Disk Replacement 5-1
- Display 3-1, 7-2
- Display Status 4-1

E

- Echo On 4-15
- EIA-232 (see RS-232)
- Electrical Module 1-2, 5-1
 - Replacement 5-1
- Emulation Modes 8-6
- Emulation, PCS 200 4-9
 - Changing the Mode of Operations 4-11
 - Command Set 4-9
 - Emulation Responses 4-10

- Engineering Units (see “Units”)
- EOI (End or Identify) 4-2
- Error Symptoms and Solutions 5-3 - 5-5
- Error Codes 1-6, 4-8, 4-9
- External Pressure Requirements 7-1
- Exhaust Pressure 7-1
- Source Pressure 7-1
- Reference Pressure 7-1
- F**
- Fan 1-2
- FCC Radio Frequency Emission Notice iv
- Filter Window 3-4, 3-11, 4-5
- Filter, Measurement 7-1
- Filters, Particle 7-2
- Fittings, Adapters 1-1, 2-1, 7-2
- Front Panel 1-1, 7-3
- Display 3-1, 3-2, 7-2
- Keypad 1-1, 3-1 -3-5, 7-2
- Functions, Summary of PCS 400M 1-5 - 1-6
- Fuses 1-2, 5-6, 7-2
- G**
- Gas Density 9-6
- Gauge Pressure Calibration Setup 6-2
- Gauge Pressure Instrument, Calibration of 6-2
- General Purpose Interface Bus (GPIB)
 (see IEEE-488-STD GPIB)
- H**
- Head Pressure 9-6 - 9-7
- I**
- IEEE-488-STD (GPIB) 4-1 - 4-14
- Command Set, PCS 400M 4-2
- Command Responses, PCS 400M 4-7
- Commands, PCS 400M 4-3
- Device Address 4-1
- Error Codes 4-7
- GPIB Interface Messages 4-1
- IEEE Capability Codes 4-1
- Local Lockout 4-1
- Output Format 4-6
- PCS 200 Emulation 4-9 -4-14
- Queries 4-4
- Service Request 4-1
- Status Display 4-1
- Tests 4-4
- Incrementing the Control Point 3-9
- Initial Inspection 1-1
- Installation iii, 2-1 - 2-2
- Mounting 2-1
- Power On 2-2
- Pressure Connections 2-1
- System Checkout 2-2
- Interface Messages, IEEE 4-1 - 4-2
- DCL (Device Clear) 4-2
- GET (Group Execute Trigger) 4-2
- GTL (Go to Local) 4-2
- IFC (Interface Clear) 4-2
- LLO (Local Lockout) 4-2
- SDC (Selected Device Clear) 4-2
- Serial Poll 4-2
- SRQ (Service Request) 4-2
- Interfaces, User 7-2
- Interfaces, Pneumatic 7-2
- Internal System Layout 1-4
- Introduction 1-1 - 1-6
- Calibration Services 1-6
- Did you get Everything? 1-1
- If you have problems 1-6
- Initial Inspection 1-1
- Meet your PCS400M 1-1
- Power Up! 1-6
- Summary of PCS400M Functions 1-5
- K**
- Keypad 1-1, 1-5, 3-1 - 3-5, 7-2
- Menu Operations 3-2
- Mode Functions 3-2 - 3-5
- Numeric Entry 3-1
- Summary of PCS400M Functions 1-5
- L**
- Liquid Density 9-6
- Local Operation 3-1 - 3-12
- Control Modes 3-8
- Default Values 3-6
- Display 3-1
- Keypad 3-1
- Manual Valves Test 3-9
- Measure Mode 3-7
- Menu Tree 3-11
- Passwords, Dual 3-10
- Transducer 3-6 -3-9
- M**
- Maintenance 5-1 - 5-6
- Beyond the Warranty 5-1
- Electrical Module 5-1
- Error Symptoms and Solutions 5-3 - 5-5
- Module Replacement 5-1
- Program Disk Replacement 5-1
- Spare Parts List 5-6
- Troubleshooting Guide 5-2 - 5-5
- Manifold 1-2, 1-3, 2-1
- MEASURE Mode 1-5, 2-1, 3-2, 3-5, 3-7
- Measure/Control Pressure Port 1-5, 2-1, 3-5, 3-7, 3-9
- Measurement Filter 7-1
- Measurement Units (see “Units”)
- Media, Pressure 7-3
- Meet your Model PCS 400M 1-1
- Mensor Background v
- Menu Tree - PCS 400M 1-6, 3-1, 3-11
- Messages, Device Dependent 4-1
- Messages, GPIB Interface 4-1
- Metric Units 1-5, 3-5
- Module, Electrical 1-2, 1-4, 5-1

Module, Pneumatic 1-3 - 1-4
 Module Replacement 5-1
 Mounting 2-1, 7-2, 8-2
 Multiple Range Pneumatics Kit 8-5

N

Numeric Entry, Keypad 3-1

O

Operating Environment 7-3
 Operation, Local 1-1, 3-1 - 3-12
 Operation, Remote 1-1, 4-1 - 4-16
 Options 8-1 - 8-10
 Bi-directional Pressure Control 8-6
 Case, Transport 8-4
 Low Pressure External Plumbing 8-9 - 8-10
 Pneumatics Kit, Multiple Range 8-5
 Pressure Emulation Modes 8-6
 Rack Mount Kit 8-2
 Orientation Effects 7-3
 Output Format for Command Responses 4-6
 Output Format for Measurement Units 9-1
 Overpressure Protection 7-2
 Overshoot 7-2

P

Packaging for Shipment iv
 Panel, Front 1-1, 7-3
 Panel, Rear 1-2
 Parts List, Spare 5-6
 Passwords 3-10
 PCS 200 Emulation 4-9 - 4-14
 Changing the Mode of Operation 4-11
 Command Reference 4-11
 Command Set 4-9
 Emulation Responses 4-10
 PLA Circuit Board 1-2, 5-2
 Please Notice iii
 Plumbing 1-3, 2-1
 Pneumatic Interfaces 7-2
 Pneumatic Module 1-3 - 1-4
 Pneumatic Module Replacement 5-1
 Pneumatic Schematics 2-1, 9-11 - 9-15
 Port, Pressure
 (see "Pressure Connections")
 Power 1-6, 2-2, 3-1, 7-2
 On 2-2
 Cord 1-1, 7-2
 Input Requirements 7-2
 Supply 1-2
 Switch 1-2, 2-2
 Up! 1-6
 Precision 7-1
 Pressure
 Bi-directional 8-6
 Control Pressure Check 2-2
 Control Rates 7-2
 Conversion Tables 9-2 - 9-3
 Media iii, 7-3

Ports (see "Pressure Connections")
 Ranges 1-1, 7-1
 Regulator 1-3, 3-9
 Specifications/Requirements 7-1 - 7-2
 Stability 7-1
 Standards 6-1, 6-2
 Units (see "Units")
 Pressure Connections 1-2, 2-1
 EXHAUST Pressure Port 1-2, 2-1
 MEASURE/CONTROL Pressure Port 1-2, 2-1
 REFERENCE Pressure Port 1-2, 2-1
 SUPPLY Pressure Port 1-2, 2-1
 Primary Transducer 3-6
 Printed Circuit Cards 1-2, 5-2
 Program Script, PCS 400M Sequence 9-16
 Program Sample, IEEE 9-8

Q

Queries, Command 4-5, 9-10

R

Rack Mount Kit 8-2
 Rear Panel 1-2
 Reference Pressure 7-1
 Reference Pressure Port 2-1
 Regulator 1-3, 3-9
 Relief Valves 7-2
 Remote Commands 9-10
 Remote Operation 3-1, 4-1 - 4-16
 IEEE-488-STD (GPIB) 4-1 - 4-4
 PCS 400M Command Responses 4-6 - 4-14
 RS-232 Serial Communication 4-1, 4-15
 User Interfaces 7-2
 Resolution 7-1
 Response Time 7-2
 RS-232 Serial Communication 4-15
 Cable Requirements 4-15
 Command Examples 4-15
 Parameters 4-15
 Setup 4-15

S

Safety (see "Warnings and Cautions")
 Schematics, Pneumatic 2-1, 9-11 - 9-15
 Sensor 1-3, 2-1, 3-6, 6-2 - 6-3
 (see also "Transducer")
 Serial Communication, RS-232
 (see "RS-232 Serial Communication")
 Serial Number (SN) 3-5
 Serial Poll 4-2
 Service Request (SRQ) 4-1 - 4-2
 Services, Calibration 1-6
 Shipping Damage 1-1
 Shipping/Packaging iv
 Shock/Vibration 7-3
 Size 7-2
 Slew Speed 7-2
 Software iv, 2-2
 Solenoid Driver 1-2, 5-2

- Solenoid Valves 1-3, 2-1
 - Source Pressure 7-1
 - Span Adjustment 6-2, 6-4, 7-1
 - Span, Setting the Sensor 6-2, 6-4, 7-1
 - Specifications, PCS 400M 7-1 - 7-4
 - Stability 7-1
 - Standards 6-1, 7-1
 - Standby 1-5, 2-2, 3-2, 3-6, 3-8
 - Status Display 4-1
 - Storage Temperature Range 7-2
 - Summary of PCS 400M Functions 1-5
 - Supply Consumption 7-2
 - Supply Pressure 3-3
 - Supply Pressure Port 2-1, 3-10
 - Switch, Power 1-6, 2-2
 - Switch, Setup 1-3
 - System Checkout 2-2
 - Control Pressure Check 2-2
- T**
- Temperature
 - Compensated 7-2
 - Conversion Table 9-4
 - Operating 7-2
 - Storage 7-2
 - Termination String Character 4-1, 4-16
 - Transducer 1-3, 3-4, 3-6 - 3-9
 - Active Transducer 3-4, 3-7, 6-1
 - Address 3-6
 - Auxiliary 1-3
 - BRT 2-1, 8-5 - 8-7, 9-13 - 9-14
 - Multiple Transducers 3-8
 - Selection 8-5
 - Tree, PCS 400M Menu 3-1, 3-11
 - Troubleshooting Guide 5-2 - 5-5
 - Error Symptoms and Solutions 5-3
- U**
- Units (Engineering, Measurement, Pressure) 1-6, 3-1, 3-5, 3-6, 4-3, 6-4, 7-1, 9-1, 9-2, 9-3, 9-10
- V**
- Vacuum Pump 2-1, 2-2
 - Valves
 - Manual Valves Test 3-9
 - Overpressure Protection 7-2
 - Relief 7-2
 - Solenoid Valves Truth Table 9-5
 - Vent 1-6, 3-2, 3-6, 3-8
 - Vibration and Shock 7-3
 - Volume, External 7-1
- W**
- Warm-up 2-2, 3-1, 7-2
 - Warnings and Cautions iii, 2-1, 2-2, 3-9, 5-1, 5-2, 5-4 6-2, 6-3, 8-2
 - Warranty ii, 1-1, 1-6, 5-1
 - Weight 7-2
- Z**
- Zero Adjustment 6-3 - 6-4, 7-1
 - Zero, Setting the Sensor 6-2 - 6-3, 7-1

User's Notes:

A large rectangular area filled with a grid of small, evenly spaced dotted lines, intended for writing notes. The grid covers most of the page below the header.



MENSOR CORPORATION
201 BARNES DRIVE
SAN MARCOS, TEXAS 78666-5994

Phone: 512.396.4200

Fax: 512.396.1820

Web site: www.mensor.com

E-mail: sales@mensor.com